



## **The Very Narrow Aisle Warehouse.**

All that's worth knowing about planning,  
processes and solutions.

  
Machines. Ideas. Solutions.



# Overview of contents.

## The subjects.

<b>Design Criteria</b> .....	4	Assembly and components .....	19
Systems in comparison .....	4	Layout .....	22
Narrow aisle storage .....	5	Preconditions for assembly .....	27
<b>Guidance systems</b> .....	6	Racking service .....	30
Mechanical and inductive guidance .....	6	Warehouse organisation .....	31
Mechanical guidance .....	7	<b>Floor</b> .....	34
Inductive guidance .....	12	Construction and requirements .....	34
<b>Racking</b> .....	18	<b>Driver assistance systems</b> .....	38
Pallet racking in narrow aisle warehouse .....	18	Systems and application .....	38





**RFID-Technology** ..... 42

**Personnel protection systems** ..... 44

**Process optimisation** ..... 48

Warehouse navigation for narrow aisle trucks ..... 48

Benefits of warehouse navigation ..... 50

Practical experience ..... 51

Warehouse navigation for wide aisle storage ..... 54

Radio data transmission ..... 56

Warehouse Management System ..... 57

Efficiency in the warehouse ..... 58

Ex Factory individual solutions for VNA trucks ..... 60

Enquiry sheet for busbar ..... 63

**Energy supply** ..... 64

Battery charging technology ..... 64

**Regulations and standards** ..... 67



## Design Criteria.

### Systems in comparison.

#### Wide aisle storage

- Floor and racking storage
- Rack bays, single or multi-position systems
- Manual operation
- Pedestrian pallet trucks, Counter-balance trucks or Reach trucks
- Typical aisle width 2500–4500 mm
- Lift height to approx. 12,000 mm
- Low to high degree of space utilisation
- Medium to high throughput
- Low to medium investment costs

#### Narrow aisle storage

- Floor and racking storage
- Rack bays as single or multi-position systems
- Manual, semi or fully automated operation
- Tri-lateral or order pickers
- Lateral load pick-up (stacking) front load pick-up (order picking)
- Typical aisle width 1400–2000 mm
- Lift height to approx. 16,500 mm
- Medium to high degree of space utilisation
- Medium to high throughput
- Medium investment costs

#### Crane/high rack warehouse

- Racking storage
- Rack bays, single or multi-position systems, silo storage
- Automated operation or manual
- Stacker cranes
- Lateral load pick-up
- Typical aisle width 1400 mm
- Lift height up to approx. 35,000 mm
- High degree of space utilisation
- Very high throughput
- High investment costs



## Narrow aisle storage.

### Characteristics

The narrow aisle warehouse allows maximum space utilisation by making the aisles as small as possible. Along with high lift heights the narrow aisle system offers high space utilisation.

Due to the single deep rack configuration each pallet position can be easily accessed. The narrow aisle trucks are designed so that order picking can take place directly in front of the cab.

Narrow aisle storage allows strategies such as first in first out to take place in a controlled environment.

### Objective

Minimising the working aisle width and maximising throughput allows the best possible utilisation of bulk storage and picking profiles, with in the same environment, using the same truck.

### Planning

It is critical to correctly plan the interfaces between rack and trucks including all relevant safety distances and racking clearances. The project management of these interfaces are vital for the success of a project.





## Guidance systems.

### Mechanical and inductive guidance.

To minimise the aisle width, fork trucks in narrow aisle systems operate with minimum safety distance to the racking. EN 1726 prescribes a minimum safety distance of 90 mm (between the trucks load handling unit and the pallet in the racking). Dependent on the type of guidance, truck type and pallet size, larger safety distances may be required.

Rail guidance on the trucks, allows high travel and lift speeds without the need for operator intervention. Guidance systems ensure safe operation and are the basis for high throughput.



## Mechanical guidance.

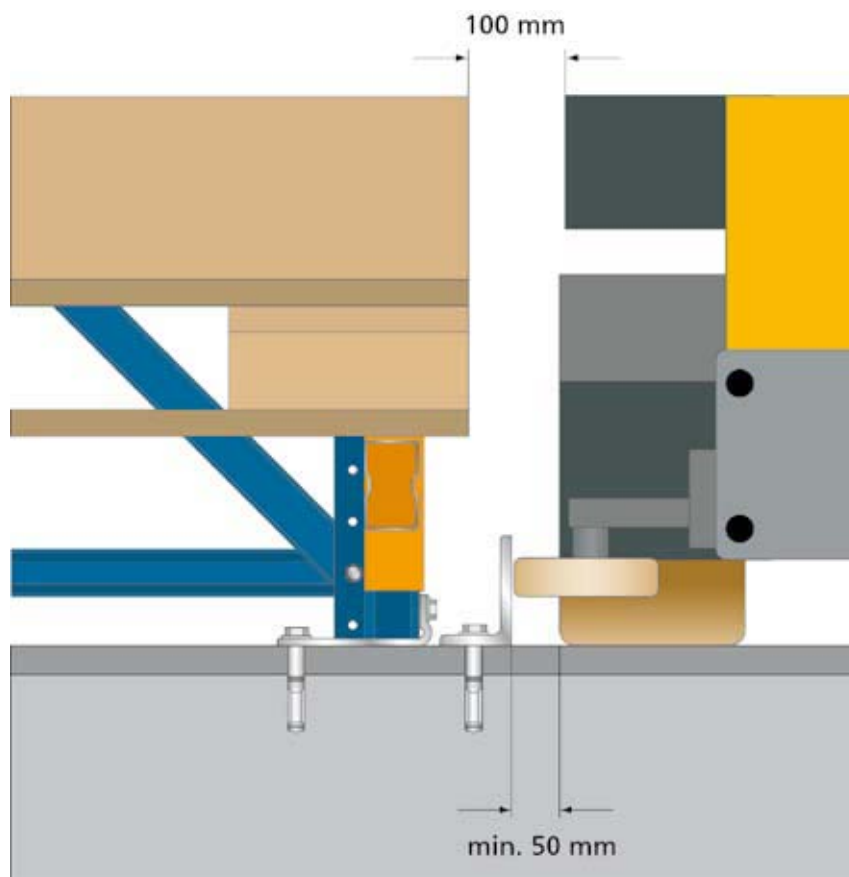

Safety distances for rail guidance

### Function principle

The truck is mechanically guided between two steel profiles bolted to the floor. Rollers fitted on the side of the chassis, 2–3 on each side, keep the truck between the rails in the centre of the aisle.

### Safety distance for rail guidance

Most favourable results regarding operational safety and throughput efficiency can be achieved with a safety distance of 100 mm for rail guided trucks.

The distance between the trucks load wheel and guide rail should be at least 50 mm. This type of layout makes entering between the rails easier for the operator.

**Working aisle width with rail guidance**

The minimum width for the working aisle (AST) is the result of stacking-in depth of the load, structural dimensions of the respective truck type and safety distances.

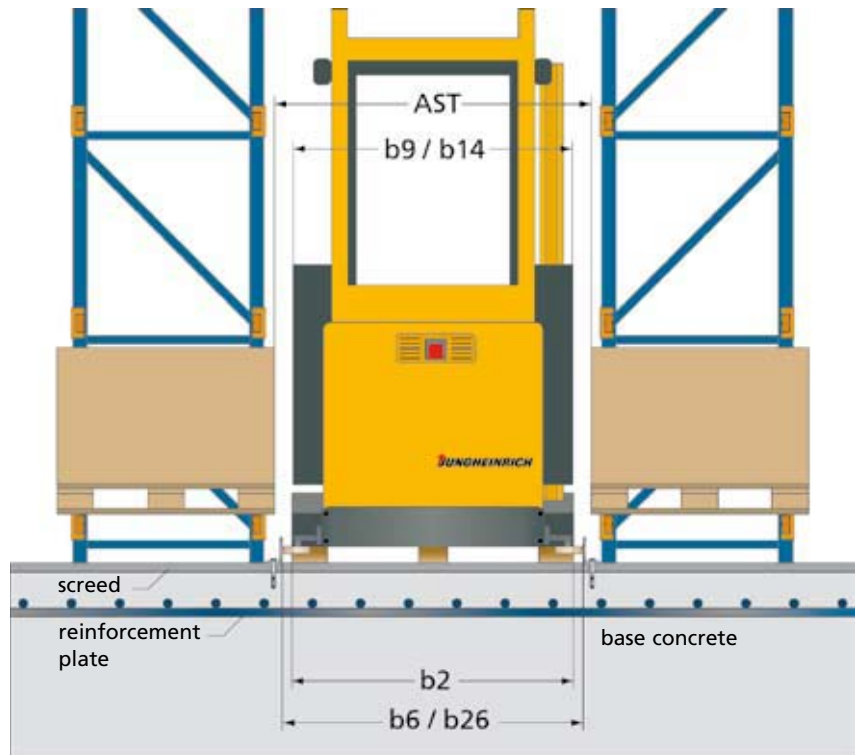

Aisle width with rail guidance

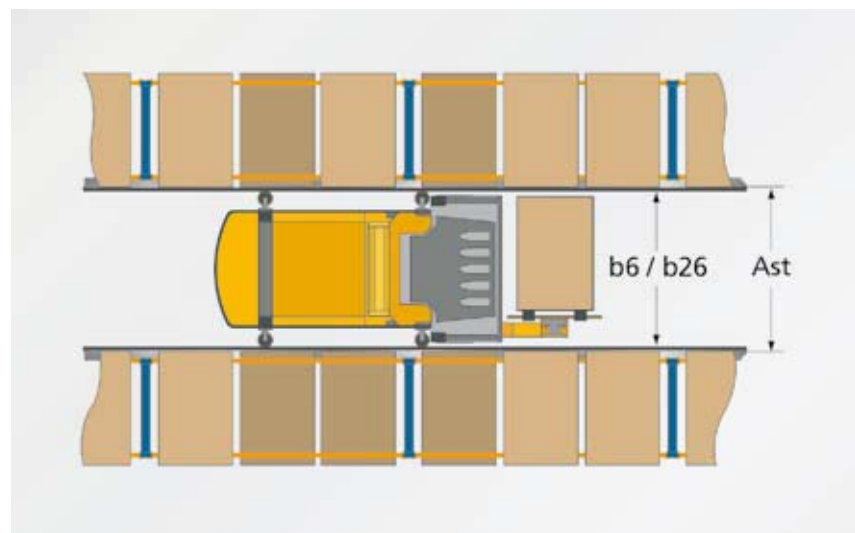

Aisle width with rail guidance

b2 load axle width  
 b6 width over guide rollers  
 b9/b14 cab/lateral frame width

b26 minimum dimension between guide rails  
 AST working aisle width



### Construction of rail guidance

Rail guidance can be installed in high and low profile rail variants and can be in-fitted with concrete or similar compounds. High rail guidance has a profile height of 100–120 mm.

If a concrete base is laid before the racking is erected, this is called a compound-filled guide rail. A low rail profile is used if pallets are deposited at ground level behind the guide rail. A high profile rail can also be installed without a compound in fill.

Depending on the requirement, different profiles can be selected according to rigidity, section, contact surface and ease of assembly.

Depending on the truck's geometry and travel speed, varied forces and moments arise. The forces are influenced by surface tolerances of the floor.

The forces are imposed onto the rail via the guide rollers. In general, trucks have four guide rollers, two at the front and two at the rear of the chassis.

At the start of the aisle, the truck is positioned between the rails with the leading guide rollers. On entry the leading guide rollers bear the main force. Lateral forces can reach up to 25 kN ( $F_1$ ). The length of the positioning area is approx. 2500 mm up to the point where all guide rollers guide the

truck. The forces in the remaining aisle run are reduced to 8 to 10 kN ( $F_2$ ).

In order to make the entry into the rails easier for the operators, a lead-in is installed at the start of the aisles. The length of the funnel or radius is approx. 300 mm with an opening angle of 15°.

Lead-ins are a high-risk area and should generally be installed with high profiles, as this would ensure safe control during the positioning process.

### Installation of guide rails

The guide rails are laid and bolted onto the floor. Allowances are made for the different forces in travel and high-risk area by appropriate bolting distances. The distance between can be 600 to 700 mm between bolts. This should be reduced to approximately 300 mm in the high-risk entry area.

The rail joints are either bolted or welded and ground on site during assembly. The welds are protected against corrosion with appropriate surface treatment.

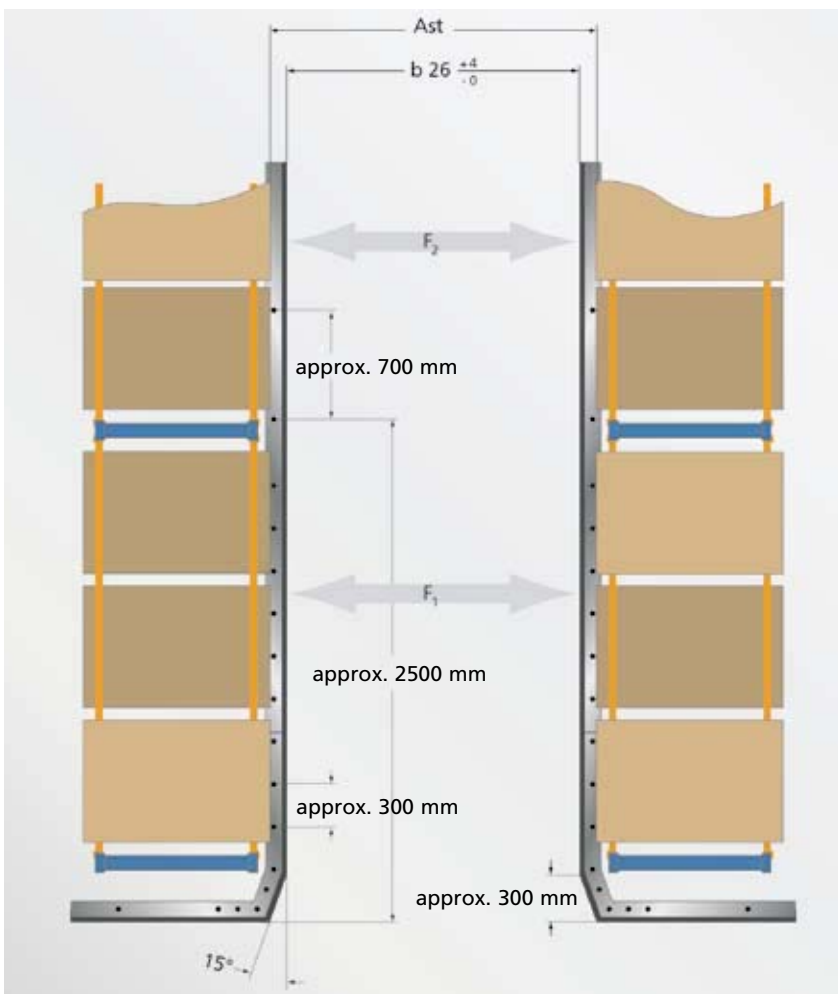

Installation of guide rails

**Examples of construction variants (profile sections may vary):**

**High profile guide rail,  
compound-filled**

- Easily cleaned floor areas
- No bottom beam required
- Same distance for working aisle and distance between guide rails possible
- Large load axle widths with high capacities can be achieved
- Acceptance of large lateral forces
- Very suitable at high lift heights
- Screeding only possible in travel areas

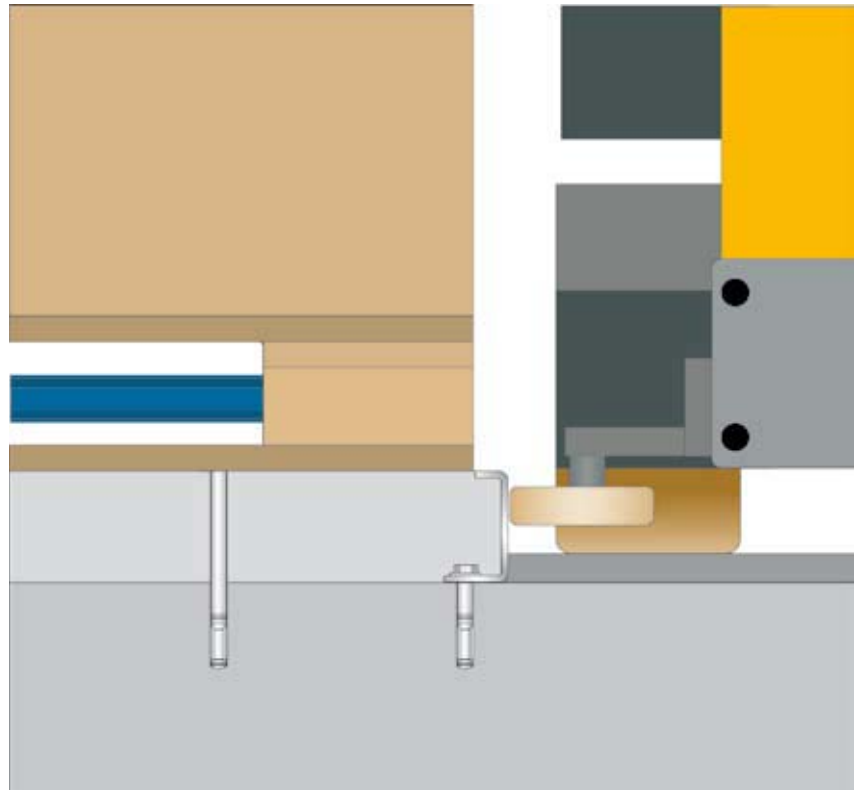

e.g.: profile C 120/6

**High profile guide rail,  
non compound-filled**

- Easy assembly
- Easy to dismantle for changes to racking
- Bottom beam required
- Application in small to medium lift heights with low lateral forces

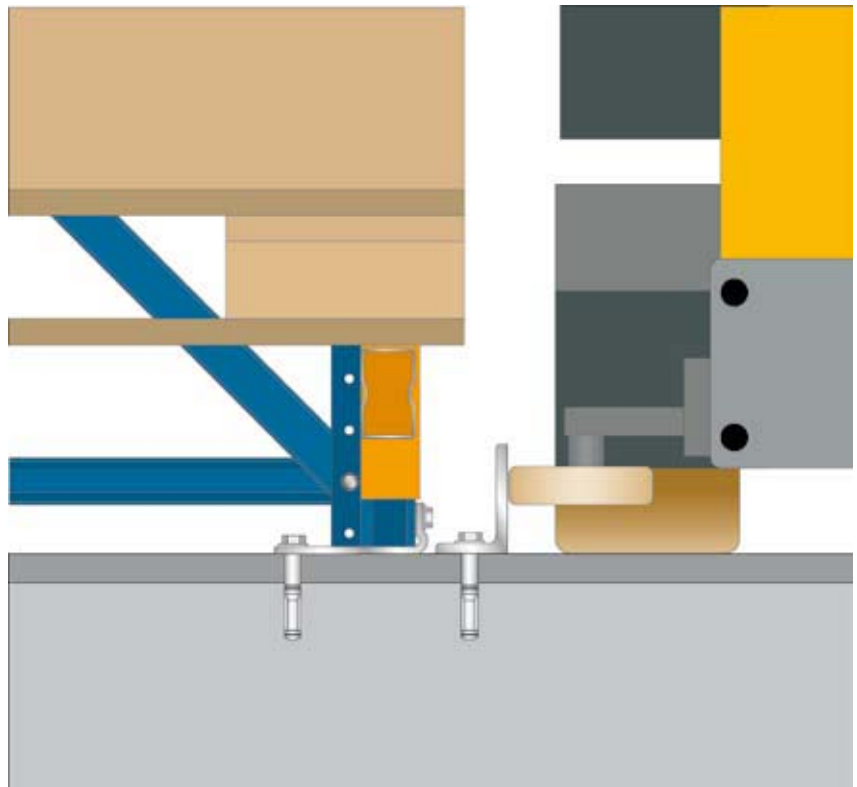

e.g.: profile L 100/65/11

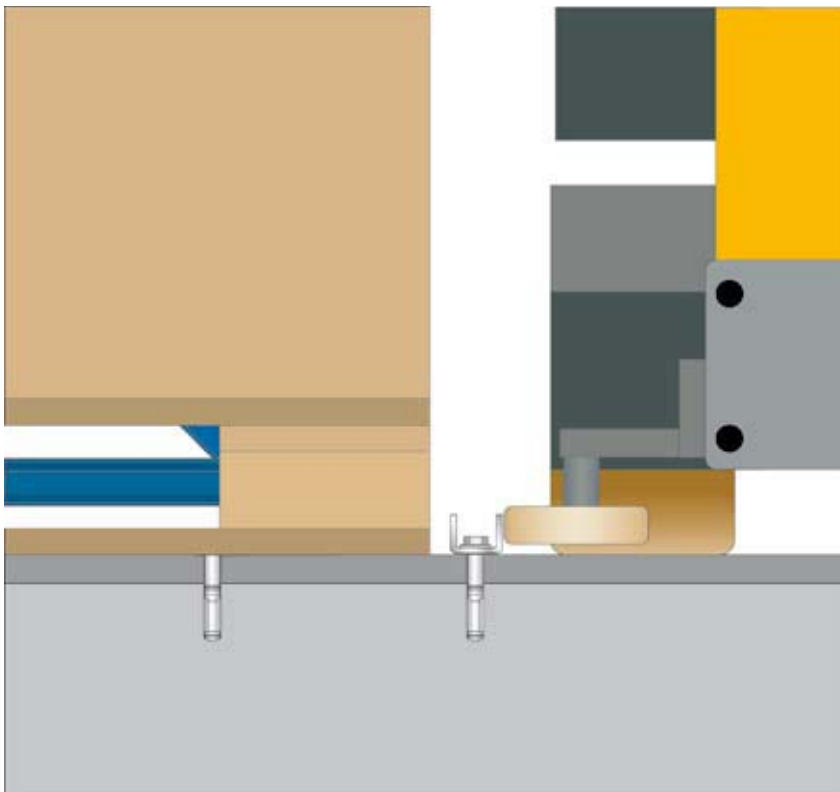

e.g.: profile U 65/42/6

### Low profile guide rails

- No bottom beam required, pick up and deposit loads directly onto the floor
- Easy assembly
- Application in small to medium lift heights with low lateral forces
- Easy to dismantle for changes to racking

### Note:

For smooth operation, a minimum clearance of 15 mm between the underside of guide rollers and the floor is recommended.

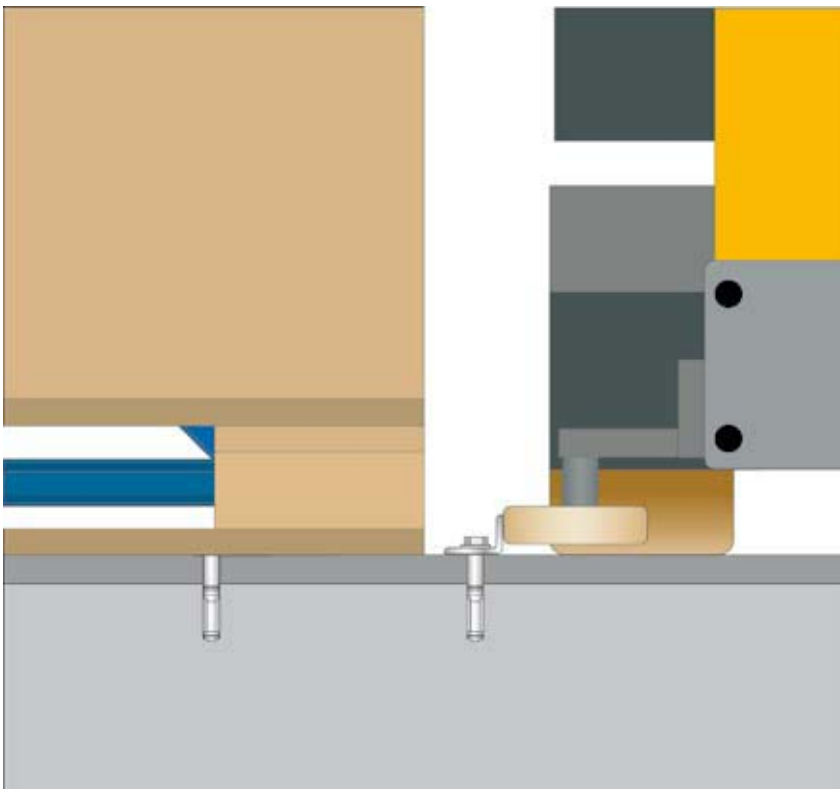

e.g.: profile L 40/60/8



# Inductive guidance (Wire guidance).

## Function principle

The inductively guided truck follows a guide wire laid in the floor. A frequency generator feeds the guide wire with high frequency alternating current (low voltage). The current produces a concentric electromagnetic field.

Antennae fitted to the truck recognise this field. Thus every deviation of the truck to the guide wire is registered. A compensation steering process is automatically initiated so the truck is safely controlled in the aisle.

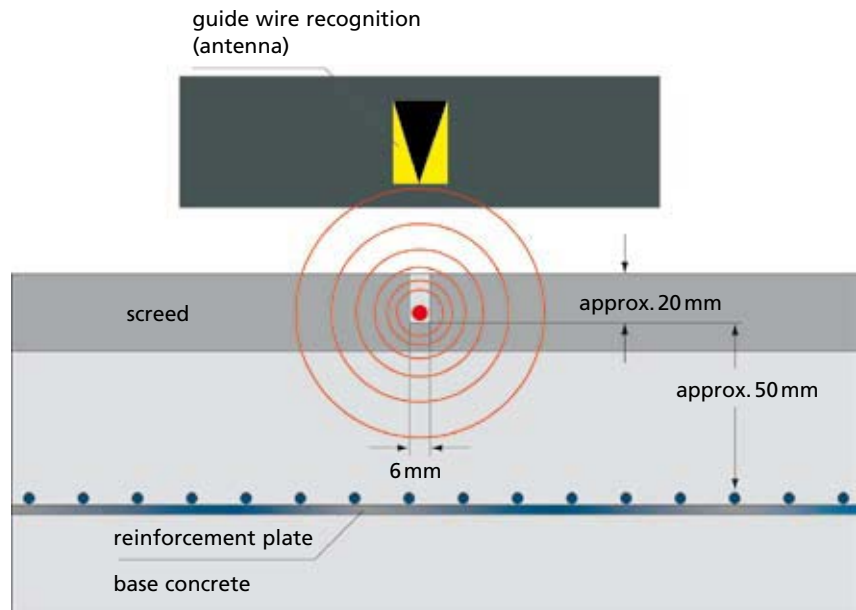

Guide wire in warehouse floor

## Warehouse floor

The following has to be noted when installing reinforcement plates or steel fibres in the floor:

To avoid a negative effect on the electromagnetic field, the reinforcement plate/grid must be installed in the concrete below the guide wire level. A distance of  $>50$  mm between guide wire and reinforcement is recommended. If steel fibres are used instead of reinforcement, an even distribution of fibres in the concrete must be ensured. The metal fibre content of the concrete must not exceed  $30 \text{ kg/m}^3$ .

Other metallic components, such as steel profiles for protection on expansion and settlement joints, should be avoided within an area of  $\pm 250$  mm relative to the guide wire and should never be arranged parallel to the guide wire. The installation instructions of the Jungheinrich Systems and Projects department must be followed without fail. Consultation with customer service is also necessary.

Where possible, the expansion joints should be placed underneath the racking; where there is not stress on joints caused by the truck.

## Electrostatic charges in the case of inductive and rail guidance

Special emphasis should be put on the floor's ability to develop electrostatic charges. The amount of conductive resistance is dependent on site conditions and the materials used, but should be less than  $10^6$  Ohm relative to ground potential. In this context, the use of insulating materials for floor construction and coating should be avoided. With an insulating coating the electrostatic charge accumulation on trucks cannot be discharged to the floor, and can lead to problems or vehicle malfunctions.

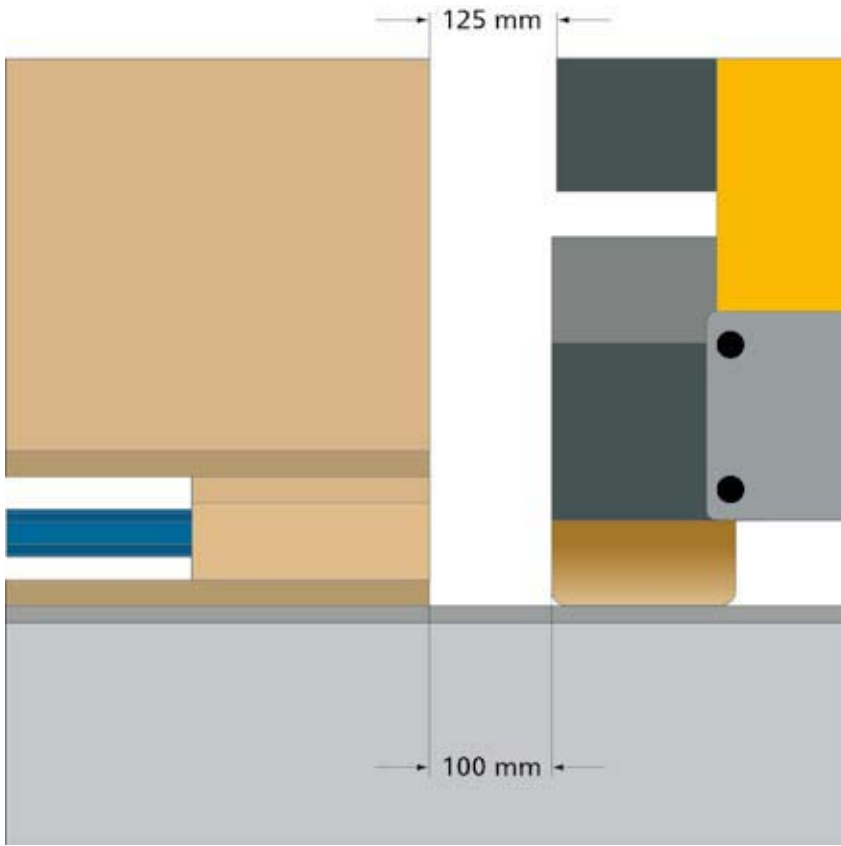

Safety distances for inductive guidance

### Safety distance for inductive guidance

Optimised results regarding operational safety and throughput can be achieved with a safety distance of 125 mm for inductively guided vehicles. The distance between load wheel and racking or stacked loads in the racking (whichever is closer) should be at least 100 mm.

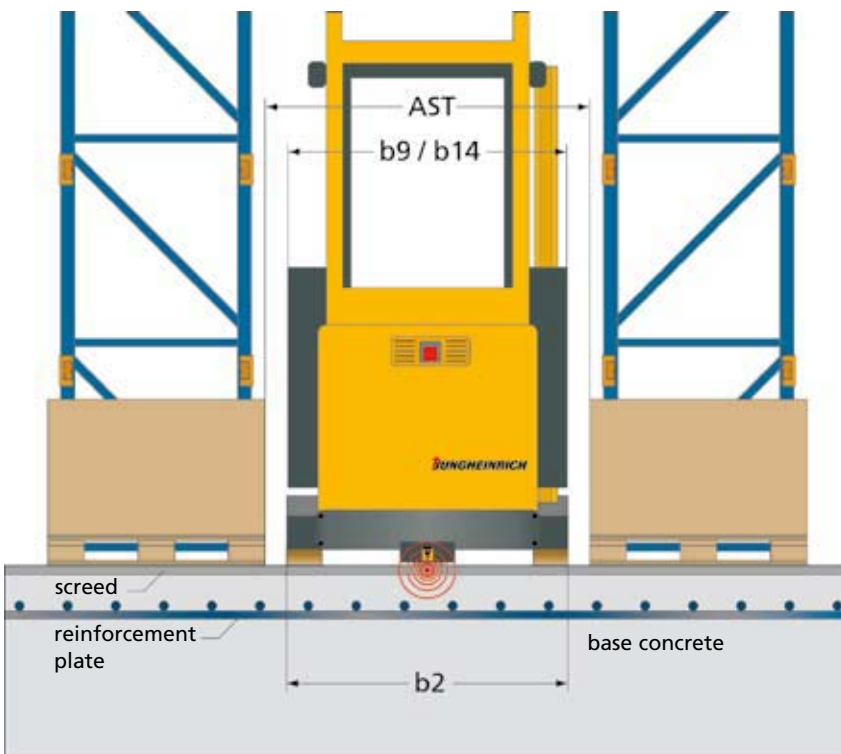

Aisle width for inductive guidance

### Working aisle width for inductive guidance

A minimum working aisle width (AST) results from the stacking-in depth of the load, constructive dimensions of the respective truck type and safety distances.

- b2 load axle width
- b9/b14 cab/lateral frame width

### Guide wire cable

For the laying of the guide wire cable, a 15 to 20 mm deep and 6 mm wide channel is cut in the floor. Water is used to limit the dust created and the residue is cleaned away.

An insulated copper cable is then inserted and the channel is filled again with an epoxy resin compound. To prevent the guide wire breaking as a result of movement or expansion of the floor slabs, we recommend that omega expansion loops are formed at the expansion joint and the joint area filled with elastic sealant. This allows the cable to compensate for floor movement or expansion. The use of double-sheathed cable is also advantageous.

If the return cable cannot be laid in the floor, it can be fixed to a wall or roof in PVC conduit.

To maintain the required tolerance of the guide wire from the aisle centre, the guide wire should be laid after the racking is installed. The tolerance of the inductive guidance line on the entire aisle length should be a maximum of  $\pm 5$  mm from the centre line of the the working aisle.



Inserting the cable

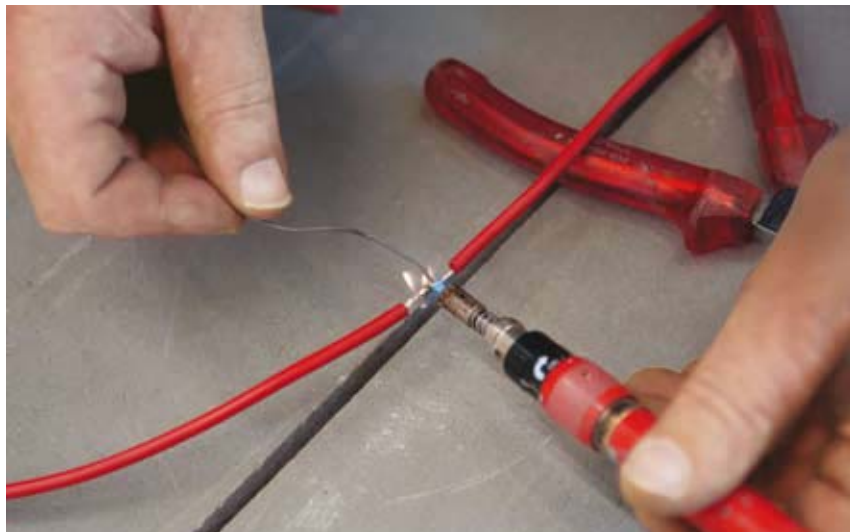

Soldering the connection points

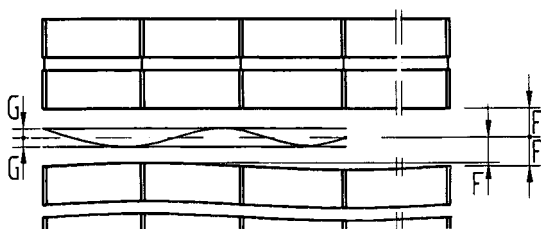

Installation tolerances and permissible deformation of the racks



### Frequency generator

A frequency generator feeds the guide wire with high frequency alternating current. Four individual loops each with a maximum length of 1000 metres can be connected to the Jungheinrich generator. If one loop is disconnected, the others remain operational.

The frequency generator should be mounted at a safe, easily accessible position. Where the mains supply can not be guaranteed, an independent voltage source (buffer battery) can be installed as an emergency power supply. Mains power failure can therefore be bridged for approx. 2 hours.

A power circuit with a separate fuse should be planned for the frequency generator and emergency power supply. The supply voltage is 220 V single phase with 50–60 Hz.



Frequency generator

Six different frequencies from 4 kHz to 9.5 kHz can be parameterised. The adjustable loop current can be assigned for each frequency from 25 mA to 120 mA. Up to three different frequencies can

be modulated into a loop, normally for safety circuitry in special applications.

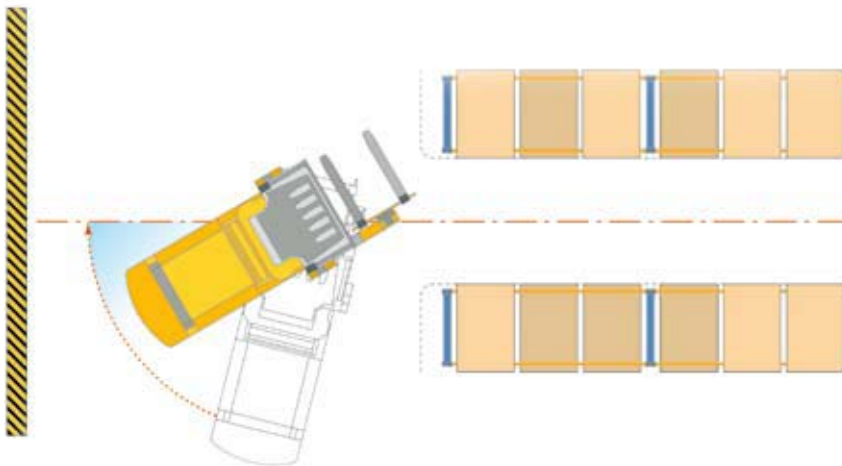

Positioning process

### Inductive guidance with high precision

The extremely high guidance precision is characteristic for Jungheinrich inductive guidance. This is facilitated by the steering in AC technology that performs positive and rapid corrections. A distinct advantage compared with traditional hydraulic steering with passive steering characteristics.

### Other advantages

- Guide wire approach up to an angle of nearly 90°
- Space-saving on the transfer aisle
- Fast entry into the aisle
- High travel speed on the guide wire
- Will detect different frequencies in the floor
- Different frequency states are possible in one wire

### Guide Wire Layout

The floor installation is laid as a closed loop. Start and finish are connected with the frequency generator (FG). An additional return wire to the frequency generator is required for an uneven number of aisles.

In order to avoid malfunction in the magnetic fields, the distance between guide wires of the same frequency should be 1.5 meters.

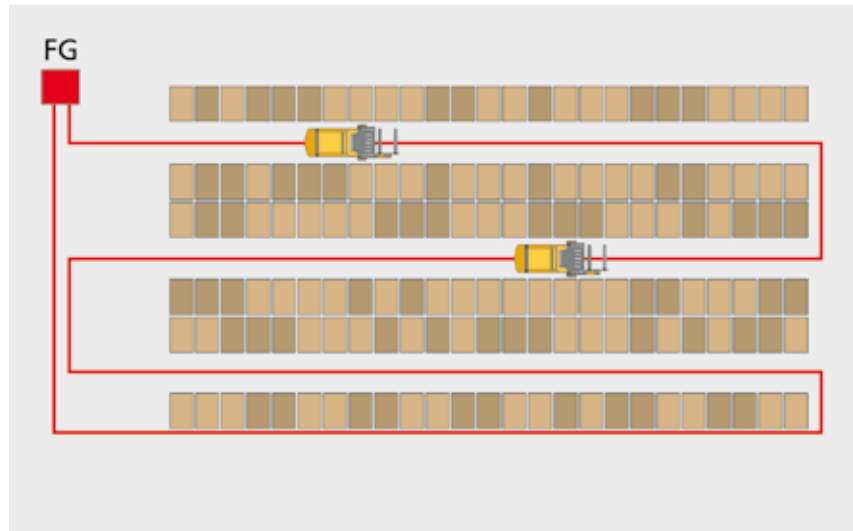

Guide wire for an uneven number of aisles

No additional return wire is required for an even number of aisles. The graphic shows a partitioning with two separate loops. If a fault occurs in one of the loops, warehouse operations can continue in the other respective area.

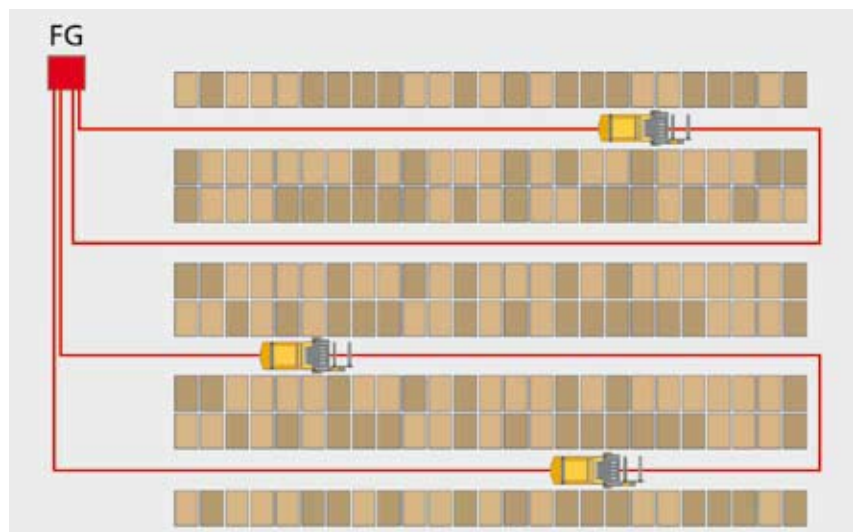

Guide wire for an even number of aisles

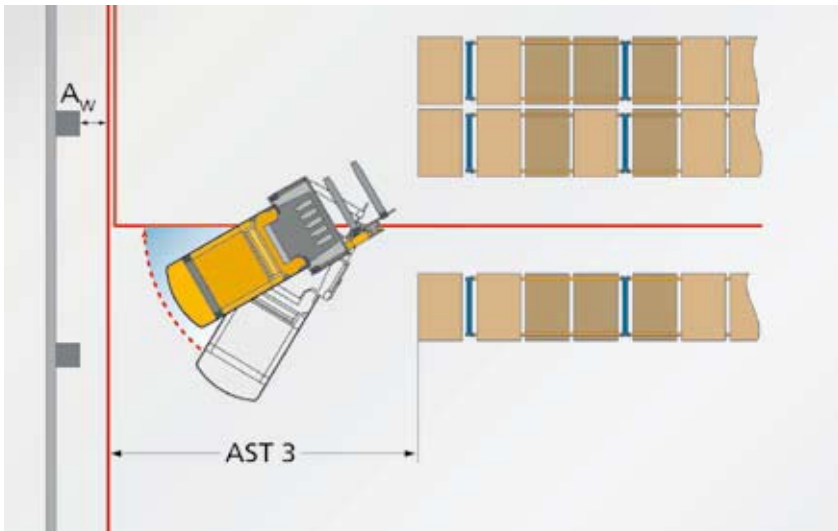

Positioning area (transfer aisle)

### Layout

To achieve a fast and unhindered positioning onto the guide wire, the wire should be extended as far as possible into the transfer aisle. A truck length including load plus 1000 mm should be applied as minimum dimension (AST 3).

The minimum distance of the guide wire from the warehouse wall ( $A_w$ ) is the result of half the cutter appliance width and the existing protrusions, such as stanchions, sprinkler pipes or other building installations.

If working aisles are designed with one closed end, the guide wire should be laid as closely as possible to the aisle end, so that the last pallet positions can be served without interruption.

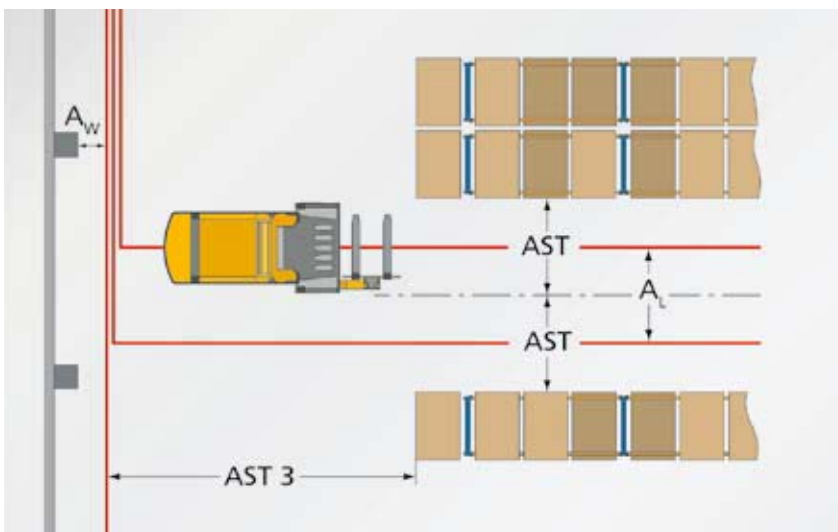

Inductive guidance in wide aisle

Wide aisles can be separated into two narrow aisles by laying two guide wires. This can be the case if a warehouse layout has previously been designed for counterbalance or reach trucks and the racking installation remains the same.

With the same frequency in the guide wires, the minimum distance ( $A_1$ ) must be 1500 mm. Alternatively different frequencies can be used. This also applies to crossed guide wires.





# Racking.

## Pallet racking in narrow aisle warehouse.

Racking is available in many designs. The assembly is adapted to the respective application and is derived from various design criteria.

The most important design criteria for racking are the unit load types, load weights and dimensions and the trucks being used. Pallet racking is used as the primary storage in narrow aisle systems. The racking can be constructed as single or multi-position systems dependent on the load weight.

Static tests are based on EN 15512 „Steel static storage systems – Adjustable pallet racking systems – Principles for structural design.“ In addition, Jungheinrich pallet racking systems conform to the following European standards: EN 15620 – EN 15629 – EN 15635.

The assembly of free-standing pallet racking is flexible as it is not connected to the building. The user has the option of later changes if the application conditions change.

### Advantages of pallet racking in narrow aisle warehouses

- Direct access to all pallet locations
- Random storage allocation possible
- Can be used in manual and automated applications
- Lengthways and crossways stacking in depths – mixed stacking also possible
- Flexible design for different unit loads
- FiFo principle
- Order picking from cab possible



## Construction and components.

### Uprights

The vertical components are called uprights. Every upright consists of two posts that are connected to a framework construction. The framework can be of a welded or bolted construction. For more flexible assembly and easier transporting, the bolted systems are the standard type. A continuous hole pattern punched in the posts facilitates the fastening of pallet beams. As a rule, beams can be adjusted in 50 mm increments, which facilitate flexible adjustment to individual requirements.

Foot plates are fixed to the uprights to allow the force placed upon the upright to be distributed evenly. The foot plates are bolted to the floor.

### Pallet beams

Horizontal beams act as the main support element for the pallet unit loads. The beams are fixed to the uprights via the holes in the uprights. A safety pin is then used to prevent the beams from lifting off unintentionally.

Profile type and profile form for supporting beams can vary depending on the unit loads. One of the most used profile forms is the box section. The profile can be fitted with additional stiffening lock beadings for improving the performance of the beam.

IPE or UNP profiles can be used for particularly high loadings. Z profiles are often used as bearing surfaces in order picking racking with shelving.

### Important note:

Damaged profiles must be replaced immediately using original spare parts!



### Shelving

Shelves can be used for smaller packaging units, such as cartons etc. Steel mesh, steel panels and chipboard are commonly used.

The capacity of the shelving must comply with imposed point and area loadings of load supports to prevent the load from sagging or caving in. The standard precondition is an even distribution of the load.

Deviations and special cases must be tested and taken into account for the static load. Reinforced beams and special frames provide support for the load unit if the load on the shelves is large and heavy.

### P&D locations

As a rule, pick up and deposit locations are designed by extending the length of the final beam in the rack structure. The final upright before the P&D location is designed with a reduced depth and therefore allows the fixing of the safety clips.

The P&D locations are usually fitted with guides. The loads are therefore deposited in the correct position by a feeder truck for the narrow aisle truck.

If roll cages are used the bottom transfer place is designed as a so-called docking station. The roll cages can then be manually pushed into the P&D location. A limit stop fixed to the floor or integrated in the racking forms the guide for the roll cage.



Compartment shelves



P&D location as separate cantilever type racking



P&D location with projecting bearing surfaces

## Back to Back Clearance

The back to back clearance of pallets should be 100 mm. However if this cannot be achieved, the directive for warehouse installations indicates that a safety stop should be fitted to stop a pallet pushing another pallet within the rack. This is a directive requirement that has to be complied with in narrow aisle warehouses with guided vehicles. EN 15512 gives two different definitions.

1. Slip-through protection  
(prevents the load being pushed through)
2. Pallet stop

The difference is made in the static design (higher design load). Unless otherwise stated, slip-through guards are used as standard.

Note: Increased back to back clearances will exist within installations with fire protective (sprinkler) systems.

## Upright protection

Collision protection corners or ground level protection barriers can be mounted as protection on all free-standing end uprights. This also applies to thoroughfares that are used for aisle changes. It is recommended, particularly at

freely accessible places, to protect the uprights against collision with fork lift trucks.

## Upright Top Level Protection

To protect persons and goods in the warehouse, end of aisle uprights at the free racking faces are extended to ensure that the pallets cannot fall. The increase must extend at least 500 mm above the top beam in order to prevent loads from falling into areas accessed by people. If the required upright height is not available as a standard dimension, bolted – on extensions can be used to achieve the required height.

## Labelling

All racks must carry a capacity/manufacture plate. Other labels for warehouse organisation or to show safety directives can be fixed.

Please also observe Page 44; Personnel protection systems – structural measures.

### Pallet rack

- Conduct regular inspections.
- Follow operating instructions.
- Are the loads within the authorised safety limits?
- Check for damage due to accidents or dislodgement of structural components.

Please report all damage to the company safety officer!

Modifications to the construction may only be executed after consultation of and approval by the manufacturer.

Do not climb racking!

The operation and maintenance of the storage equipment has to be carried out according to the EN 15635 – Steel static storage systems.

If in doubt always contact manufacturer!

Max. compartment load		Year of manufacture	<input type="text"/>
Max. compartment load		Rack type	<input type="text"/>
Max. compartment load		Order number	<input type="text"/>
Max. compartment load		Max. bay load	<input type="text"/> kg
Max. bay load		Max. level distance	<input type="text"/> mm
		Frame profile	<input type="text"/>

Clear bay width	Profile	Max. compartment load
mm	<input type="text"/>	kg
mm	<input type="text"/>	kg
mm	<input type="text"/>	kg
mm	<input type="text"/>	kg

The max. field load must not be exceeded by summation of component loads. Component loads are uniformly distributed loads. Damaged or deformed rack components must, due to the significant reduction of the bay load, be replaced immediately. Please refer to the assembly and service instructions.

Dungheinrich UK Ltd.  
Head Office  
Dunstable House, Dunstable Drive  
Thames, Milton Keynes MK7 8JG  
Phone +44 (0)1525 324100  
Fax +44 (0)1525 324100  
info@dungheinrich.co.uk  
www.dungheinrich.co.uk

DUNGHEINRICH

Sample labels

## Overhead Protection

Racking areas where truck or pedestrians can walk under the racking structure must be equipped with overhead protection.

Pedestrians can be protected from falling load units or stored goods falling through by lattice inserts, wooden covers or chipboards. The same measures must be taken if order picking areas, e.g. tunnelling, are integrated within the pallet racking.

## Spacing pieces

If two single racks form a double rack, the uprights are connected with spacing pieces. The length of the spacing pieces results from the load overhang on the storage location and the required safety distance between loads on double racks.

The spacing pieces are screwed to the uprights and can be prepared for the fitting of sprinkler pipes.

## Safety Mesh

To protect against goods falling off the racking, the sides of free-standing single racks that are not intended for stacking and retrieval must be fitted with safety mesh. The mesh is available as standard sections, and is prepared for fitting to the back of the rack.

The fitting of wire mesh at the respective racking side is also possible.



# Layout.

## Single and double racking

High bay racking can be designed as single or double racking. While single racking is mainly served from one side, both sides need to be accessible in double racking. Double deep storage is the exception when two pallets are stacked one behind the other. This variant is only serviceable to a limited extent with high rack stackers.

As a rule, single racking is arranged in front of a wall while double racking forms the middle part of a racking installation.

The layout for a racking installation consisting of single and double racks is dependent on the usable floor space, load dimensions and required safety distances, the working aisle widths and the column/support grid of the building that has to be integrated into the racking installation.

If the building already exists, the racking installation will be adapted to the existing frame.

If a new building is planned, the design will aim at an optimum solution. The architect can arrange the space as an optimum envelope around the racking installation. A precondition is that the site areas are available in sufficient size and shape and there are no restrictions regarding building height.



Layout



Planning

### Safety distances – clearances in the racking

According to EN 15620, clearances are defined as follows: "Clearances are the nominal dimensions of distances between moving and stationary system components that have to avoid a collision in case of the most unfavourable combination of all relevant tolerances and deformations."

Distances are, for example:

- distances of loads to each other (x2)
- to racking uprights (x1)
- to bearing surfaces (y)
- to site installations (sprinklers, pipes, cable links, lighting, supports, etc.)

General conditions for planning distances are:

- load weight and load dimensions
- height level of the top level of the racking
- type of narrow aisle trucks being utilised (man-up or man-down)
- degree of truck automation
- assistance systems used (warehouse navigation, rack level height selection, automatic stacking-in/out etc.)

The clearances are determined as minimum dimensions. The distances in detail may be also determined by locally applied directives and standards.

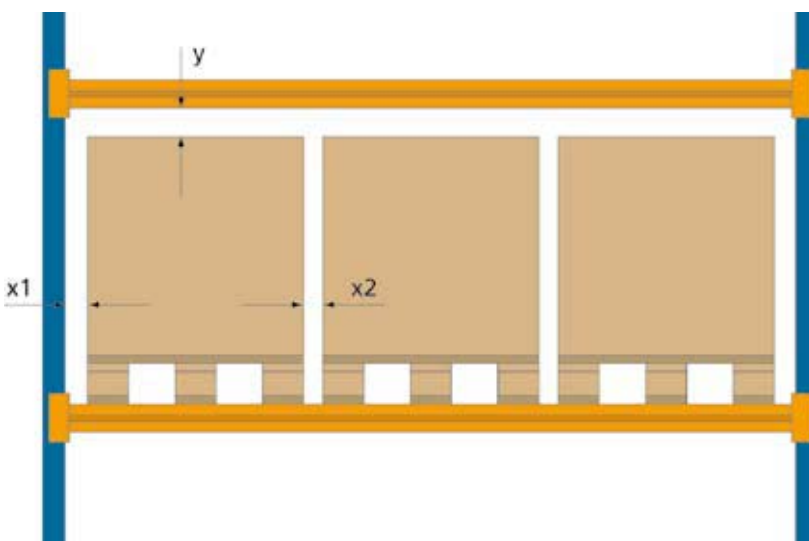

Safety distances

### Intersecting Aisles

If intersecting aisles for trucks are planned, there must be adequate clearance and protection. The width of the aisle is to be modelled on a transfer aisle. The clear height is the maximum closed height of trucks being utilised, plus a safety distance of at least 200 mm.

The uprights at the sides of the passage must be fitted with corner protection; stored objects above the passage must have appropriate covering. The narrow aisle trucks can be fitted with a travel and lift stop in order to allow operation through the passage only with a closed mast.

### Working aisles

The way to determine the working aisle (clear dimension between the racks or the stored goods in the racking) has already been mentioned in the "Guidance Systems" chapter.

During the installation of the racking, the maximum load overhang over the load unit (pallet etc) are taken into account. This could also be a flap on box pallets and stillages opened for order picking that could affect the racking design. If the building already exists, care has to be taken that existing supports and other parts of the building or installations do not protrude into the working aisle (Ast).

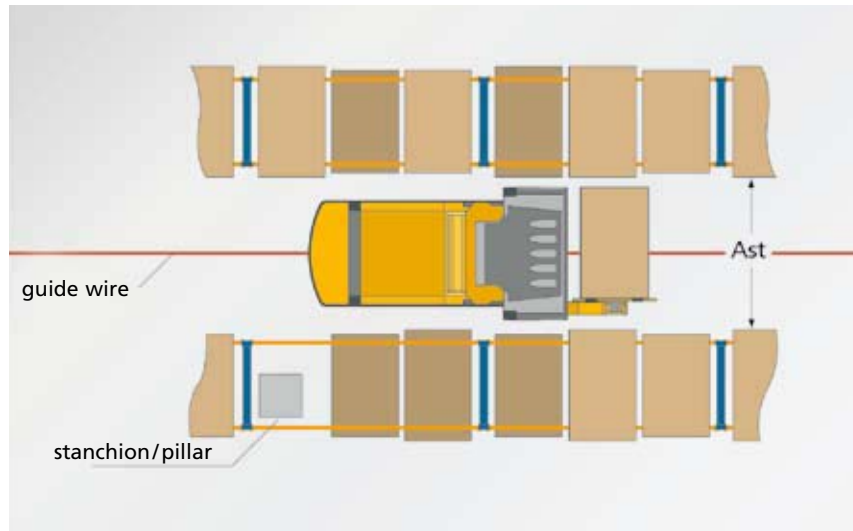

Working aisle

### Transfer aisle

The transfer aisle (AST3) is designed for a smooth aisle change of a narrow aisle truck from aisle A to aisle X. A clear dimension for AST3 is the truck length of the respective type including the largest load plus an additional dimension dependent on the type of guidance (minimum dimensions: 1000 mm for inductive guidance, 500 mm for rail guidance).

In some cases and depending on general conditions, a larger transfer aisle may be recommended. A quick, smooth and safe aisle change should be the main consideration during planning. Providing areas for goods, and traffic areas for other trucks in addition to the transfer aisle should be taken into account.

Several transfer aisles could be advantageous for optimising work cycle times in large racking installations. Transfer aisles could be planned at both ends of racking installations or the installation could be split in the middle by a transfer aisle.



Transfer places

### P&D locations

P&D locations placed at the end of the racking, provide storage locations for the loads for the narrow aisle trucks. Dependent on the load units, the transfers can have different characteristics. The simplest is to have the loads deposited in a marked area in front of the racking. The number of P&D locations (in the height) depends on the feeder trucks utilised in the narrow aisle warehouse.

Places not used as P&D locations can be designed as normal storage spaces. Such places above the transfers must be protected against falling loads.



Escape door at the end of the working aisle

### Escape and rescue routes

The distance from each point within the warehouse to the next fire escape route/door should be a maximum of 30 metres in the air or 50 metres by foot. These dimensions may deviate in the building regulations of individual countries. If due to the maximum distance an escape route is required to run straight through the racking installation, the following design criteria must be adhered to:

According to the respective workplace directive, the aisle width for the escape route must be designed according to the number of people working in that area. A minimum of 0.87 metre clear aisle width for up to five persons and a minimum of 1.00 metre clear aisle width for up to 20 persons are required. The clear height must be at least 2.00 metre. Unauthorised use of escape routes by people must be prevented.

Notices must be put up to ensure that routes are not obstructed or blocked.

If the escape route in an area can only be achieved at the end of a racking aisle, escape doors or a transverse passage must be planned. Racking levels above the escape route must be protected against falling load units and stored goods.

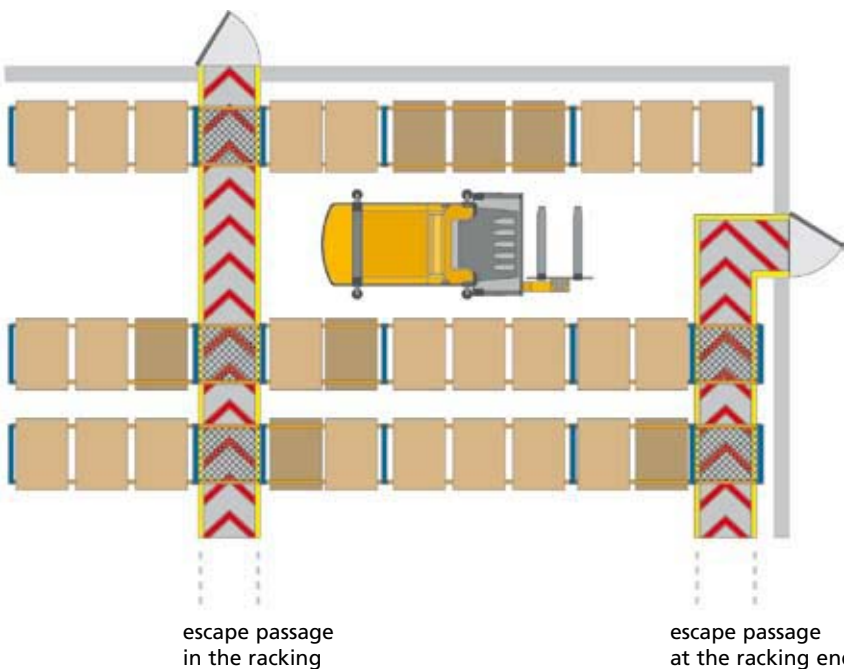

escape passage in the racking

escape passage at the racking end

Escape routes



### Fire protection in the racking

Fire protection measures in the warehouse are an important safety aspect. Early agreement with insurance partners, approval authorities and implementing companies ensures advantages for the building owner.

Sprinkler heads are to be placed at protected spots in the racking. Respective precautions have to be taken for piping and fixing. The space required for fire protection measures must be taken into account regarding safety distances.



Sprinkler

### Protection area classification according to fire hazards

For the calculation of a sprinkler installation, a fire hazard classification must be established before the start of planning. The regulations VdS CEA 4001 (planning and setting up of sprinkler installations) is an important factor here. As is the regulatory reform (fire safety) order 2005.

The buildings and areas to be protected must be allocated to one of the following hazard classes according to their utilisation and fire hazards:

LH	Small fire hazard	HHS	High fire hazards, storage risks Respective protection areas are divided into classes HHS1 to HHS4
OH	Medium fire hazard Respective protection areas are divided into classes OH1 to OH4		
HHP	High fire hazard, production risks Respective protection areas are divided into classes HHP1 to HHP4		The fire hazard of stored goods is dependent on the inflammability of the stored material, the packaging and the type of storage.

# Pre-requisites for assembly.

## Floor

Correct functioning of pallet racking is only ensured if the floor within the installation complies with the requirements of the applicable technical standards as described below.

### Load-bearing capacity of the floor

According to EN 15512, DIN 15629 and instructions contained in EN 15635, installation areas for warehouse facilities and equipment must be designed to bear the unladen weights and permissible payloads safely.

The permissible floor compression must be higher than the value specified for the shelving system. The person ordering and/or operating the pallet racks is responsible for ensuring that the floor is designed and built to bear the load of the uprights for the rack.

Here, the maximum surface load of the entire covered surface and the point load of the forces introduced via the feet of the uprights must be taken into consideration.

The field load is the sum of all shelf loads relative to a beam length, with the exception of stored goods placed directly on the floor. The sum of all shelf loads must not exceed the permissible field load. The posts load and the uprights load respectively result from the field loads applied from the right and left.

### Floor quality

A minimum concrete quality of C20/25 with corresponding reinforcement (EN 206-1) is assumed for the warehouse floor. The warehouse floor must be at least 20 cm thick and allow floor anchoring with expansion plugs; drilling depth: approx. 15 cm.

Increased wear on the drill is to be expected with reinforcement diameters (reinforcement steel mesh) exceeding 8 mm and/or reinforcing bars positioned above one another.

Special protective measures to prevent the formation of corrosion are required with aggressive or magnesite-based floors.

### Floor tolerances

The levelness of the warehouse floor must as a minimum comply with the structural engineering tolerances as defined in chapter "Floor".

### Floor sagging

When installing pallet racks, sagging, in particular in the case of suspended floors, can have a significant influence on the correct functioning of storage facilities. For stationary storage facilities, sagging, measured at the widest span, must not exceed  $0.75 \times 1/500$ .

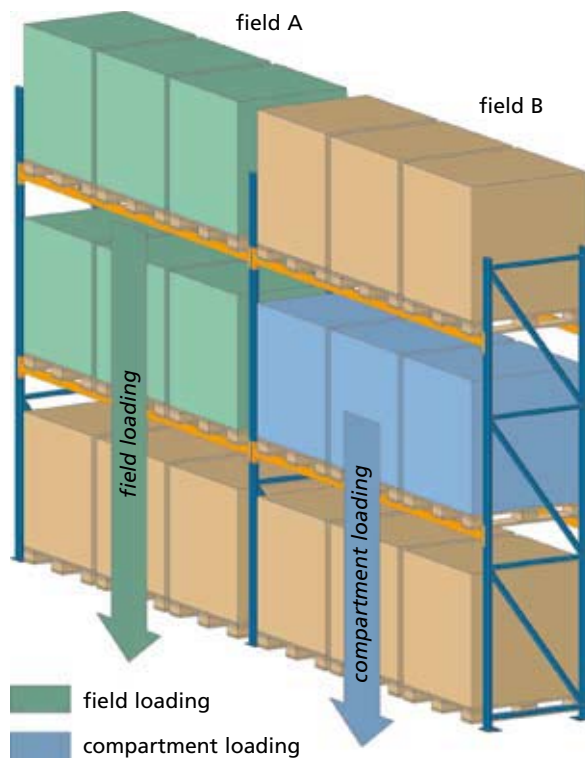

## Assembly

Before erecting the uprights, preassembly is required for screwed systems. For this, a clear temperature and lit room must be available.

The mounting areas must be freely accessible for the final assembly of the racking installation. Some assemblies, e.g. laying the inductive floor installation, should definitely not be carried out before the racking assembly in order to ensure adherence to the required tolerances.

A rolling or phased sequence of different assemblies is possible in large installations. When part of the racking is erected, other installations follow.



## Assembly tolerances

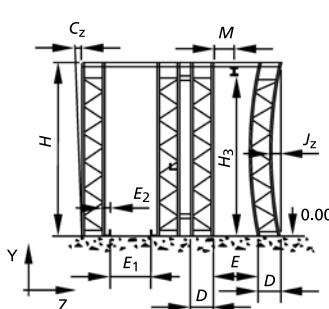
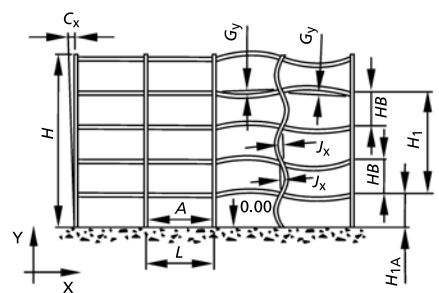
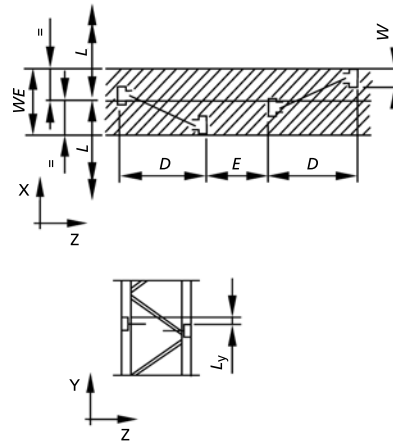
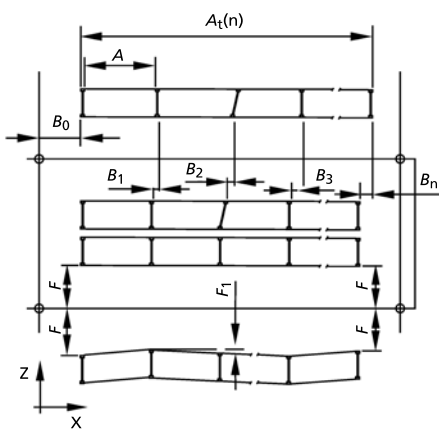

- $A_Z$  Clear entry between two uprights
- $B_0$  Distance between system Z datum and front of racking
- $B_1, B_2$  Misalignment of uprights across an aisle in bays 1 and 2 respectively
- $C_Z, C_X$  Out of plumb of upright in the Z and X directions respectively
- $D$  Rack frame depth
- $E$  Aisle width
- $E_1$  Distance between guide rails
- $E_2$  Distance between guide rail and front of upright
- $F$  Distance from aisle system X datum to front face of upright
- $F_1$  Variation between adjacent uprights measured near floor level in the Z direction
- $G_Z, G_Y$  Straightness of the beam in the Z and Y directions respectively
- $H$  Height from top of base plate to top of upright
- $HB$  Height from top of beam level to top of beam level above
- $H_Y$  Variation of support levels between the front and rear beams in a compartment
- $H_{1A}$  Height from top of base plate to top of bottom beam level
- $H_1$  Height from top of bottom beam level to top of any other beam level
- $J_X$  Upright straightness in the X direction between adjacent beam levels
- $J_Z$  Initial straightness of an upright in the Z direction
- $L$  Distance from centre to centre of uprights
- $M$  Distance from front of upright to centre of top guide rail

## Assembly tolerances and admissible deflections of racking and guidance systems following EN 15620

**Excerpt from European Standard EN 15620 (Table 7)**

<b>Horizontal tolerance limitations for the X Z plane (mm)</b>		
<b>Measuring dimension code and description of tolerance</b>		<b>Installation tolerances for racking class 300</b>
$\delta A$	Variation from nominal dimension of the clear entry width between two uprights at any beam level	$\pm 3$
$\delta A_t$	Variation from nominal dimension of the total rack length, cumulative with the number of bays "n" measured as near as possible to the base plate	$\pm 3n$
		The larger value of the following:
$B$	Misalignment of an upright across an aisle, cumulative with the number of bays "n" measured near floor level For class 300A, this applies for the aisle uprights only For class 300B, this applies for the aisle and rear uprights	$\pm 10$ or for class 300A: $\pm 1,0n$ for class 300B: $\pm 0,5n$
$\delta B_0$	Variation from nominal dimension of rack frontage at the P and D end, with regard to the installation "system Z datum line" concerned, measured near floor level	$\pm 10$
$C_X$	Out of plumb of each frame in the X direction	$\pm H/500$
$C_Z$	Out of plumb of each frame in the Z direction	for no fixed stroke: $\pm H/500$ for fixed stroke: $\pm H/750^*$
$\delta D$	Variation from nominal dimension of the rack depth (single or double frames)	single frame: $\pm 3$ double frame: $\pm 6$
$\delta E$	Variation from nominal dimension of the aisle width near floor level	$\pm 5$
	Variation from nominal dimension of the width between guide rails	$+5/0$
$\delta E_2$	Variation from uprights on one side to guide rail	$\pm 5$
$\delta F$	Variation from nominal dimension of the straightness of an aisle measured near floor level with regard to the "Aisle system X datum line" or as specified by the truck supplier	$\pm 10$
$F_1$	Variation between adjacent uprights measured near floor level in the Z direction	$\pm 5$
$G_Z$	Straightness of the beam in the Z direction	$\pm A/400$
		The larger value of the following:
$J_X$	Upright straightness in the X direction between beams spaced $HB$ apart	$\pm 5$ or $\pm HB/750$
$J_Z$	Initial curve of an upright frame in the Z direction	$\pm H/500$
$\delta M$	Tolerance of the top guide rail	Defined by the specifier or truck manufacturer
$T_w$	Beam twist at mid span	$1^\circ$ per m

\*  $H/500$  is also an acceptable value provided the pallet blocks or bearers overhang the front beam by 75 mm or more and the blocks or bearers are supported on the beam.

**Table 8 from EN 15620**

<b>Vertical tolerance limitations for Y direction (mm)</b>		
		The larger value of the following:
$G_Y$	Straightness of the beam in the Y direction	$\pm 3$ or $\pm H_1/750$
$\delta H_1$	Variation of the top of any beam level $H_1$ above the bottom beam level	for class 300A: $\pm 5$ or $H_1/500$ for class 300B: $\pm 3$ or $H_1/1500$
$\delta H_{1A}$	Variation of the top of the first beam level from the floor level at each upright	$\pm 7$
$\delta H_3$	Tolerance of the top guide rail, if provided	Defined by the supplier or the truck manufacturer
$\delta H_Y$	Variation of unit load support levels between the front and rear beams of a compartment	$\pm 10$

To ensure problem-free operation, we recommend compliance with tolerance limitations  $C_Z$  for the pallet rack both in unladen and in laden state. This is important to ensure compliance with the safety distances in the narrow aisle.



## Racking service.



### More safety at all levels

The Jungheinrich racking service is an important means by which the employer can fulfil the requirements of the ordinance on industrial health and safety for work equipment. The ordinance prescribes that the employer must have all equipment that is subjected to harmful influences inspected by approved persons within the designated inspection periods.

Even the best pallet rack is subject to wear and tear over time. And even when working with the utmost caution, damage to racks can hardly be avoided. (Attention: Damaged parts must be replaced immediately with original spare parts!) If loading equipment is moved, beams moved, load signs are mislaid... The result is major safety risks in some cases, plus loss of performance and in the hustle and bustle of the working day, these are often only recognised when it is too late. The Jungheinrich racking service can help you to prevent this situation. It includes a wide

range of tests which make a major contribution to ensuring the safe operation of every pallet rack.

- Racking service in accordance with EN 15635 "Adjustable pallet racking – Guidelines for safe use"
- Verification of compliance with the guidelines for storage facilities and equipment (FEM or SEMA) as specified by the trade associations
- Visual inspection of uprights and beams for visible deformation and damage, carried out from the warehouse floor
- Comparison of the load signage with the actual configuration
- Check on the actual configuration of the pallet rack system in accordance with the assembly drawing (where available)
- Creation of a test report
- Issuing of a test sticker documenting successful inspection
- Submission of offers for the replacement of damaged or missing parts



# Warehouse organisation.

Rack rows/rack position numbering for space allocation, ABC classification, distance optimisation and inventory management.



## Identification example:

**1<sup>st</sup> block of digits:**  
**Rack rows or rack aisles**  
 Two-digit number from 01 to 99 denoting the order of the rack rows/aisles

**3<sup>rd</sup> block of digits:**  
**Height position in the rack**  
 One- (1-9) or two-digit number (01-99) defining the exact height position in the rack



**2<sup>nd</sup> block of digits:**  
**Horizontal position in the rack**  
 Two-digit number from 01 to 99 denoting the exact horizontal position in the rack

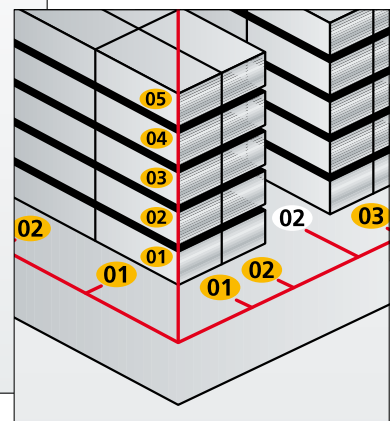
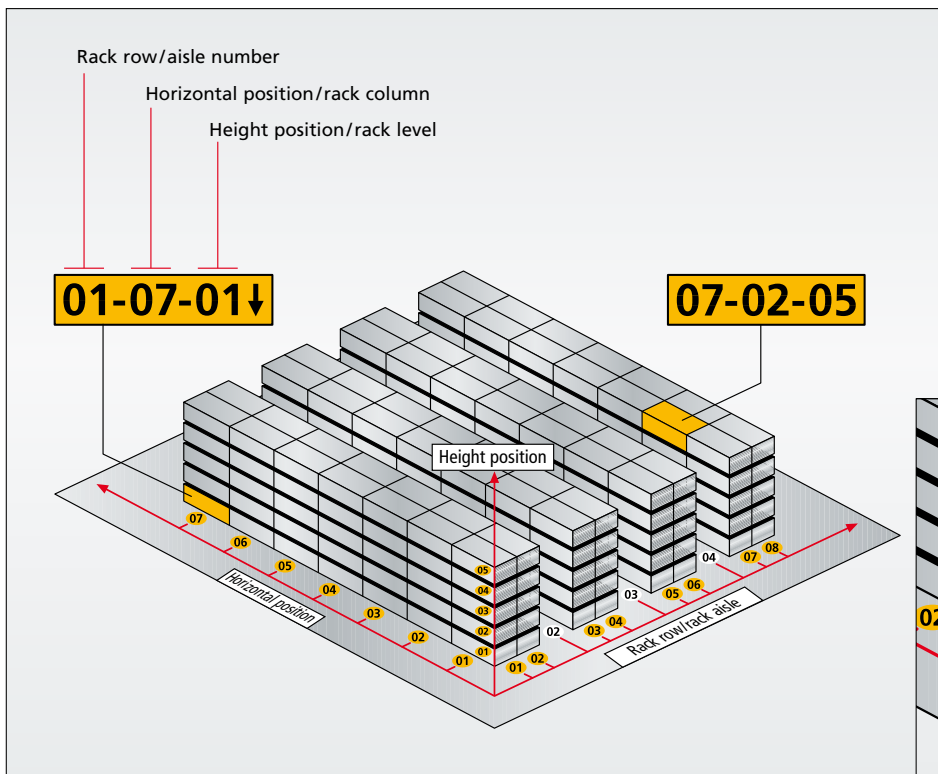
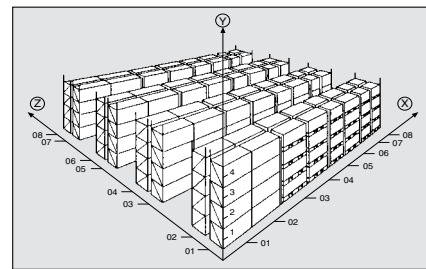

**Self-adhesive labels**



Three blocks of digits (with a maximum of three digits per block. Numerical, alphabetical, alphanumerical). Additional blocks on request. Barcodes can also be added.

**Plastic plates**



Numerical, alphabetical, alphanumerical, can be labelled with a maximum of two characters. Ready for installation, can be attached without tools. Customised special designs of up to 1000x1000 mm on request.

**Magnetic labels for self-labelling**



White PVC film on a magnetic backing for labelling with felt-tipped pens (water-soluble/permanent). Can be cleaned with water or methylated spirits.

**Numbering plan for numbering of rack spaces**

Company: \_\_\_\_\_ Numbering plan: \_\_\_\_\_  
 Project: \_\_\_\_\_ For Order No. \_\_\_\_\_  
 Person responsible: \_\_\_\_\_ Tel.-No. \_\_\_\_\_

07 06	20 34	5 02	
1 <sup>st</sup> block of digits	2 <sup>nd</sup> block of digits	3 <sup>rd</sup> block of digits	4 <sup>th</sup> block

Examples of typical numbering

Rack row or rack aisle	Parallel position in the rack	Height position in the rack	Special characters	Number of rack spaces
<b>Total number of rack spaces</b>				

Special characters (mark with a cross where applicable or fill in):  
 None     Hyphen     Slash     Full stop     Arrow     Barcode

Front-end \_\_\_\_\_ Size: \_\_\_\_\_ Quantity: \_\_\_\_\_  
 Colour     Yellow     White





### Floor markings

Self-adhesive floor markings made from heavy-duty PVC, suitable for quick, flexible and inexpensive marking of routes and pallet positions.

- Floor markings can be replaced quickly and easily
- Available with barcode on request



### Magnetic C-profiles

A popular and effective solution for flexible and mobile labelling. They can be attached time and time again, adhering to any ferrous surface. For racking fronts, transport boxes, cupboards, machines, tool benches, to name just a few examples. The C-profiles are flexible and can thus be attached to slightly curved surfaces. Matching label strips (included in the case of cut-outs) or perforated A4 sheets in card thickness are available for these profiles.

### Label holders and label holder strips

Label holders and label holder strips are practical when you need your labelling system to be variable. They can be used for all rack types, are made from impact-resistant hard PVC and equipped with optional magnetic or self-adhesive backing. Inserting the labels into the holders is simple. And moving or exchanging the labels later is just as easy. The barcodes remain readable for a scanner. Use label holders for individual labels or label holder strips for the whole width of a rack.

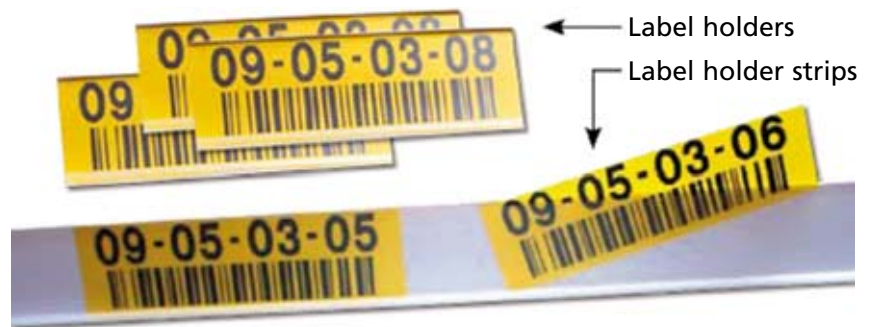





## Floor.

### Construction and requirements.

The function and productivity of a narrow aisle warehouse is decisively influenced by the floor, and in particular by its flatness. The sub-base and floor plate must be dimensioned in such a way that permitted tolerances are not exceeded under load conditions.

#### Construction

As a rule, industrial floors consist of a sub-base, a concrete layer and surfacing (screed). Layers underneath the concrete layer serve, for example, as subsoil compression, moisture protection or heat insulation.

#### Requirements

With regard to strength, the surface layer (screed) must conform to loading group II of DIN 18 560, part 7, table 1. The floor must not deform under load. Shafts, channels or similar breaks in the floor must be arranged with a minimum distance of 200 mm from the tracks of the truck. Such installations in the working aisle should generally be avoided.

The floor must be resistant to oil and grease. The track covering should be non-abrasive and must not be susceptible to dust developing.

The resistance to earth according to IEC 1340-4-1 EN 1081, should not exceed  $10_6$  Ohm. This needs to be a large 10 with a small 6 higher up next to the 0. The frictional coefficient of the floor should permit the observance of ISO 6292 (Empirical value: approx.  $0.5 \mu$ ).



### Standardisation

National standards are applied. The load-bearing surface must comply with the relevant standards (e.g. Concrete society TR34 Chapter 4). Taking into consideration possible settling, the load-bearing surface must be prepared in such a way that the angular tolerances of the finished floor do not exceed 15 mm.

The tolerances based on DIN 18202 (see table 1) and similar to BS5606 apply for all areas of the warehouse floor. In the narrow aisle area, the tolerances stipulated in the VDMA guideline apply: Floors for use with VNA trucks ([www.VDMA.org](http://www.VDMA.org) → Sectors → Materials Handling and Logistic Technology).

The requirements of this VDMA guideline can be met if due care is taken.

### Floor quality

Today's high bay warehouses are technologically very advanced systems allowing the user to realise high throughput rates with substantial volume utilisation. This not only results in increased technological requirements with regard to the fork lift trucks, but also means that vehicle-related systems, for example the floor, need to meet certain minimum requirements. Compliance with the requirements of the VDMA guideline "Floors for use with VNA trucks" is mandatory in order to realise the full potential of the equipment.

The VDMA guideline focuses on three areas:

- Levelness requirements
- Evaluation of waviness
- Definition of a measurement method for waviness



### **Adjusted levelness requirements**

The VDMA guideline defines levelness requirements both along and across the wheel tracks. The basic principle for measurement of these criteria is contained in existing standards and widely applied in industry.

### **Evaluation of waviness**

This formulation of the floor requirements is based on the definition of a figure ( $F_x$ ) arrived at by static methods (standard deviation) by examining a series of height differences from adjacent measuring points. Lower  $F_x$  values mean greater waviness with greater amplitudes and thus poorer floor levelness. The guideline describes in detail how to calculate the figure. The guideline and the calculation tool for automatic calculation of the figure from raw data are available for download on the VDMA website.

### **Definition of the measurement method for waviness**

The VDMA guideline also gives a clear definition of the measurement method and offers a schematic drawing of the set-up for measurement. This ensures that the readings are reproducible and comparable. See the VDMA guideline (Section 4.2.3) for the requirements with regard to the waviness of the floor.



EKX 515, lifting height 16.5 m

### Finished floor outside the narrow aisle area (apron)

Spacing of the measuring points up to	0.1 m	1 m	4 m	10 m	from 15 m
Max. permissible variation from levelness (pitch)	2 mm	4 mm	10 mm	12 mm	15 mm

**Table 1**

### Height differences lateral to the direction of travel based on the VDMA guideline

The guideline is available for download on the VDMA website.

See Appendix B1 for an example calculation.

Top racking level (m)	$Z_{\text{SLOPE}}$ (mm/m)	$dZ = Z \times Z_{\text{SLOPE}}$
15	1.0	$Z \times 1.0$ mm/m
10	1.5	$Z \times 1.5$ mm/m
up to 6	2.0	$Z \times 2.0$ mm/m
Note: Interpolation is required for rack heights > 6 m		

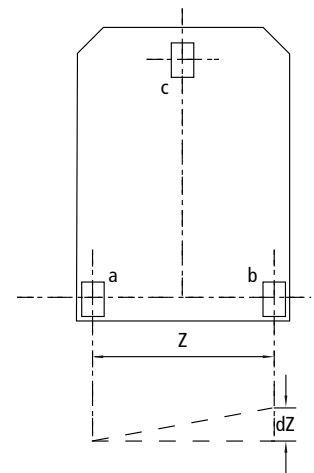

Z is the dimension between the centre of the fork lift truck load wheels (a, b) in m and  $Z_{\text{SLOPE}}$  is the permissible slope across the aisle between the centre of the fork lift truck load wheels (a, b) in mm/m.

Parameter dZ is the height difference between the centres of the fork lift truck load wheels (a, b). dZ is specified as shown.

### Levelness tolerances along the direction of travel for all heights, based on the VDMA guideline

Spacing of the measuring points	1.0 m	2.0 m	3.0 m	4.0 m
Max. permissible variation from levelness, pitch as limit value in the tracks	2.0 mm	3.0 mm	4.0 mm	5.0 mm

**Table 2**

See the VDMA guideline (Section 4.2.3) for the requirements with regard to the waviness of the floor.





## Driver assistance systems.

### Systems in use.

The following points apply with regard to safety in a narrow aisle warehouse:

- Easily visible driving areas when leaving the aisle
- Protection at areas of on-site limitations
- Protection of persons entering the working aisles

In Germany, various directives and regulations apply for the operation of a narrow aisle warehouse. In countries where this is not the case, the following measures are recommended for consideration.

#### Legal situation in Germany

The latest regulations on health and safety at work (BetrSichV of 3.10.02) transfer greater personal responsibility to the operators of warehouse facilities. The occupational safety act stipulates that it is the responsibility of the operator to define what work safety measures are required during operation of his narrow aisle warehouse.

Where it is not possible to comply with prescribed safety distances between racks and trucks or where constructional measures to separate the narrow aisle areas to prevent access by personnel are not possible, the operator must take alternative measures. A risk assessment must be carried out to ascertain whether the necessary degree of safety for personnel can be achieved by means of alternative measures.

The risk assessment is commissioned by the user in his function as employer and must take into account all interactions in the workplace. The manufacturer of the VNA truck provides the operator with all necessary information such as operating manuals and further information, see Machinery Directive MRL 2006/42/EG, Article 5(1)c. As a rule, this information will enable the operator to carry out the risk assessment as required.

Possible driver assistance systems are:

- End of aisle controls, lift and drive cut-outs, speed reductions
- Personnel protection systems
- Warehouse navigation

In general, these are realised by means of Jungheinrich transponder technology (see next chapter).

#### End of aisle controls

Measures to increase safety include methods to make the ends of aisles clearly recognisable and to provide protection against collisions with constructional limitations resulting from the building layout and technical equipment.

Due to health and safety considerations, it is highly recommended that a speed reduction system is employed to provide a reduction of the truck. This also applies to transverse aisles in the warehouse, with the exception of emergency escape routes.



For trucks with end of aisle control braking before the aisle exit or at the closed end, two basic variants are possible:

1. Braking to a halt

When the truck passes over the end of aisle control (switching position in the floor via transponder) whilst travelling towards the end of the aisle, it comes to a halt. In order to move on again, the truck operator must briefly release the drive control and then activate again. The truck can then be driven out of the narrow aisle at max. 2.5 km/h.

2. Braking to 2.5 km/h

When the fork lift truck passes over the end of aisle control (switching position in the floor via transponder or magnets) whilst travelling towards the end of the aisle, its speed is reduced to 2.5 km/h, and it can then be driven out of the narrow aisle at this speed.

Attention: In both variants described, the stopping distance depends on the travel speed.

**General information on the lift and travel cut-outs**

The lift and travel cut-outs are additional functions to support the driver and are used for applications with limited warehouse headroom or in connection with roof beams.

Assistance systems support the driver during operation of the vehicle. However, they do not release the driver from responsibility for:

- Hydraulic movements, e.g. stopping the function prior to contacting an obstacle,
- Braking, e.g. applying the brakes where necessary when travelling at the ends of aisles, to avoid striking an obstacle etc.

Lift cut-outs are often combined with travel cut-outs. For this reason, all Jungheinrich system trucks are equipped with a lift and a travel cut-out as standard, and the transponder technology offers a high degree of flexibility with zone-dependent settings.

All displayed commands can be assigned to individual aisles or warehouse areas, and new parameters can be quickly and easily set. And of course, further lift and travel cut-outs can be ordered as options.

### Lift cut-out

There are various types of lift cut-out (e.g. general lift restriction, zone-dependent lift cut-outs with override etc.). These cut-outs stop the main and/or auxiliary lift at a defined height, thus avoiding e.g. striking roof beam during the lifting process.

The factory setting for the lift cut-out (1000 mm) is adjusted as required on-site by the Jungheinrich service technicians during commissioning of the vehicle. If a driver overrides the lift cut-out, e.g. between two roof beams, he/she is warned that he/she is operating in a high-risk area and needs to proceed with caution. The driver must pay particular attention to obstacles when the mast is extended.

The lift cut out is re-activated each time the mast height is below the lift limit height. As mentioned above, a lift cut-out alone is usually not ideal and should be combined with a travel cut-out.

### Travel cut-out

There are various types of travel cut-out (e.g. general cut-out, cut-out with override, zone-dependent cut-outs etc.).

The symbol "Travel cut-out override" lights up on the display if travel is no longer possible from a certain lift height or in a specific area. If, however, the position of the truck needs to be adjusted with respect to the rack in order to stack or retrieve a load, the operator can, if permitted, initiate a travel cut-out by pressing the "Travel cut-out" override button.



Lift and travel cut-out

Various travel or hydraulic speeds as well as travel or hydraulic functions can be enabled under the corresponding override symbol. These override functions are set as required by the Jungheinrich service technicians during commissioning of the vehicle.



### Lower cut-outs

If necessary, due to on-site conditions, the fork lift truck can be equipped with an optional automatic lower cut out. This automatic lower cut out, which becomes effective below a certain lift height, prevents the main lift being lowered.

The driver can release the lock by pressing the "Lower cut out" override button. The lower cut out is thus rendered inactive and various travel or hydraulic speeds as well as travel or hydraulic functions can be enabled. These override functions are set as required by the Jungheinrich service technician during commissioning of the vehicle. The lower cut out is then re-activated each time the mast is raised above the lower cut out height.

Assistance systems support the driver during operation of the vehicle. However, they do not release him/her from his/her responsibility e.g. to stop the hydraulic prior to contacting. When the lower cut out is deactivated, the driver must pay particular attention in order to recognise obstacles when lowering the cab or the load carrying unit.

### Personnel protection systems

A further possible alternative measure is the use of Jungheinrich personnel protection systems (PSS Professional or PSS Professional plus). If it is not possible to achieve the required degree of safety, the employer should contact his local occupational safety office or the trade supervisory board. You can find further information on Jungheinrich personnel protection systems beginning on page 44.



Lower cut out for a picking cage



# RFID technology.

## Transponder technology provides

- Information for controlling narrow aisle trucks
- Ground control and communication with the rest of the warehouse
- Different commands and speed profiles

## The transponder as an information medium

Controlling narrow aisle trucks in aisles and warehouse zones is a decisive criterion for safe operation and maintaining all prescribed functions such as end of aisle control, lift cut-out and speed reduction. Traditional systems tend to use floor magnets or reflector markers for this. By using "magnet combinations" the system enables specific zones to be identified and corresponding safety switching to be applied mechanically - for example, automatic stop before the truck leaves the aisle. However, this mechanical or optical switching only allows a very limited amount of information to be sent to the truck. In many cases this is simply inadequate for systems that are becoming increasingly complex with associated rigorous safety requirements.

Transponders are used to control the Jungheinrich narrow aisle trucks. The transponder dimensions are a mere 9x16 mm, and they are inserted in the warehouse floor at intervals of not more than 10 metres. The truck itself is equipped with an RFID reader/writer that communicates with the transponders and selects and uses the following information:

- Identification of the aisle number and aisle type
- Distance measuring referencing within the aisles



RFID transponders store every cm<sup>2</sup> of your warehouse



Pioneers since 2007: High speed transponder technology

Armed with the above information and the truck's travel distance measuring system, the system allows locations to be determined precisely within the aisles at all times. The writer teaches the transponders. The warehouse topology is stored in the memory of the

truck's on-board computer. This means that switching functions can be activated on any route, such as speed reduction for crossing escape routes or lift cut-out in aisles with limited overhead clearances.



**GPS in the warehouse – precise positioning in every application**

### **Maximum flexibility – minimum maintenance**

The main advantages offered by transponder technology are maximum flexibility for each individual application and also for future changes in the warehouse environment. In the past limited information to the truck restricted the user due to the position of magnets or reflex markers, transponder technology now offers complete freedom. If a rack row changes or if more storage locations are added, the transponders are simply “re-taught” and the new structure is stored in the truck’s on-board computer. Cut outs can be configured via a laptop and adapted to new situations. An important advantage, particularly for logistics service providers.

As the transponders are protected in the ground, the technology is not vulnerable to faults or contamination, as is often the case for example with barcode systems and reflex markers.

### **Reliability**

Jungheinrich transponder technology also meets the strictest criteria in terms of data processing reliability and safety.

The entire computer system on the narrow aisle truck is a two channel redundancy system with master and backup computers.

Data communication between the on-board computers and from the computers to the motors and sensors is via a safety-enabled and TÜV-certified CAN-Bus (TÜV – German Technical Control Board).

### **Adapting performance to ground conditions**

Transponder technology offers not only safety advantages, it also enables the speed performance setting to be adapted to the prevailing ground conditions. In practice, the floor levelness often determines the maximum travel speed ( $V_{max}$ ) of the truck. In many cases the floor quality is not consistent and generally the travel speed has to be reduced due to the number of poor spots. The new system now allows you to adapt the speed performance level to each situation, meaning you only have to travel slowly where the floor dictates. Pallet throughput rates can thus be enhanced.

### **Installing the transponders**

The transponders are installed at a depth of approx. 2 mm below the floor surface (drill depth 20 mm) with a backfill of silicone (acid-free based). The distance to the centre of the aisle is 245 mm.

### **Example for transponder installation in closed end aisle:**

Rail guidance width 1670 mm : 2 = 835 – 245 = 590 mm

Then a template can be made to serve as an installation aid.

Three transponders must be installed at the start of the aisle.

1 at a distance of 0 mm – start of the aisle (in line with the first rack post).

2 at a distance 500 mm – into the aisle from transponder 1 position.

3 distance 5000 mm – into the aisle from transponder 2 position.

All other transponders should be installed at distances of ~10,000 mm.



**Transponder**

# Personnel protection systems.

## Health and Safety guideline

Pedestrians and fork lift trucks should not be present in a narrow aisle at the same time ("staggered operations").

Health and safety guidelines confirm that users must ensure that adequate personnel protection is provided in all hazardous operations or conditions. It is the users responsibility to carry out a risk assessment to ensure that no dangerous or hazardous situations arise or exist.

While operating a fork lift truck in the narrow aisles, the driver's attention is focused on the stacking, retrieval or picking process. As the VNA fork lift trucks do not maintain a distance of 0.50 metres from the racks, it is dangerous for pedestrians to be in the narrow aisle at the same time as the fork lift truck.

Residual risks as a result of failure to observe this guideline must be eliminated. It must be ensured that personnel are protected despite the fact that fork lift trucks do not maintain the prescribed safety distances while operating in narrow aisles.

The following additional measures should be considered (as appropriate) to achieve this aim:

### ■ Structural measures

e.g. walls, fences, doors, climb-through protection in double racks, safety labelling by means of traffic signs

### ■ Organisational measures

e.g. company operating instructions and training for warehouse personnel, traffic control, written instructions for fork lift truck drivers

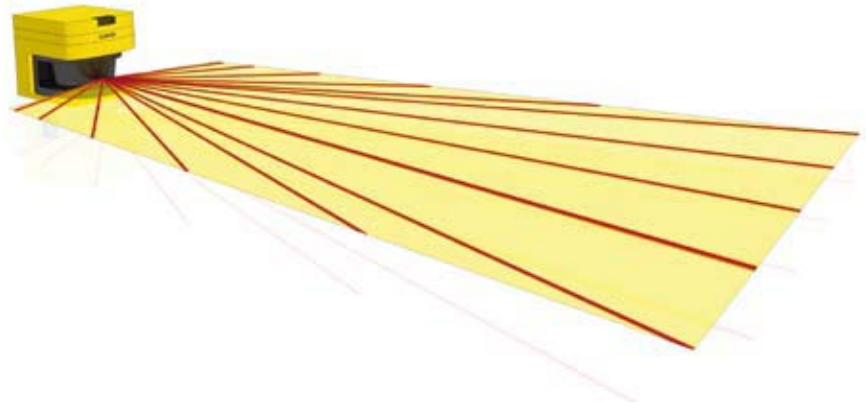

Laser scanner with monitoring field



Monitoring fields of the mobile PSS

### ■ Technical measures at accesses to the narrow aisles

e.g. stationary, opto-electronic personnel protection system – fitting of light barriers on entry points to the respective rack aisle.

### ■ Technical measures on fork lift trucks

Laser scanners on the VNA fork lift trucks.



### Stationary, opto-electronic personnel protection systems

In the stationary systems, light barriers are fitted on the entry points to the rack aisles or in entire access areas.

One-way light barriers are used to detect persons. Access is monitored at two heights, 400 mm and 900 mm, by means of two one-way light barriers (active column) or with one one-way light barrier and dual reflection (passive column). For safe and reliable truck detection, an optical detection system which also clearly identifies the direction of travel is used. This also allows precise counting of the trucks, into and out of the aisle.

As a rule, in stationary control of aisle access (per aisle or for the entire system), a distinction is made between operating modes "Truck operation" and "Personnel access."

In operating mode "Truck operation," an authorised vehicle can drive into and out of an empty aisle unhindered. However, should a pedestrian enter the aisle despite the fact that access is prohibited (light signal), an alarm is immediately triggered (a visual alarm in the form of a flashing light and an acoustic alarm by means of a horn).

must be reset at the entrance to the corresponding aisle by an authorised person by means of a key-operated switch.

In operating mode "Personnel access," one or more persons may enter the aisle. If a truck enters the aisle despite the fact that access is prohibited for trucks, (traffic light), an alarm is immediately triggered (flashing light, horn). The alarm must be reset at the entrance to the corresponding aisle by an authorised person by means of a key-operated switch.

If required, in addition to the optical and acoustic warnings, the trucks can also be stopped from travelling via a signal from the aisle protection system if the alarm is triggered. Depending on the trucks and their guidance system, the following possibilities are conceivable:

- Stopping via an additional frequency-enable in the case of inductively guided trucks
- Stopping via a radio frequency
- Stopping via an infrared sensor system (receiver on the truck, transmitter stationary)

Monitoring of escape doors (fire escapes etc.) or controlling the lighting in the aisle are further possibilities.

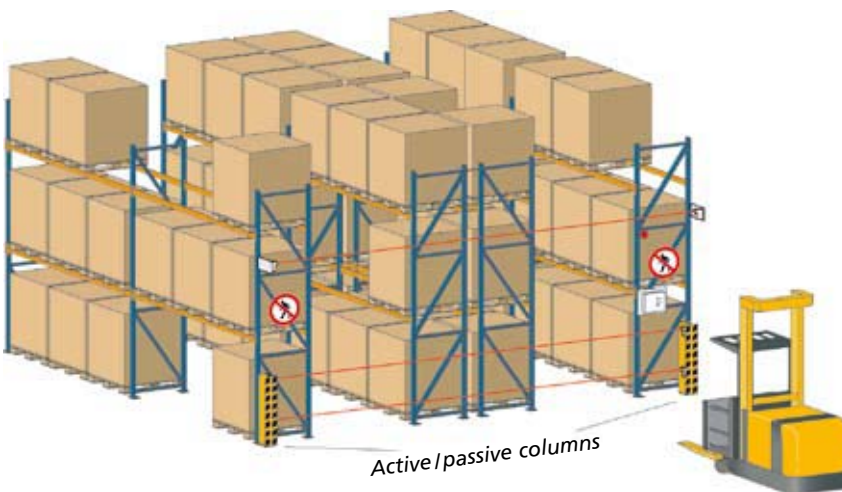

Block protection

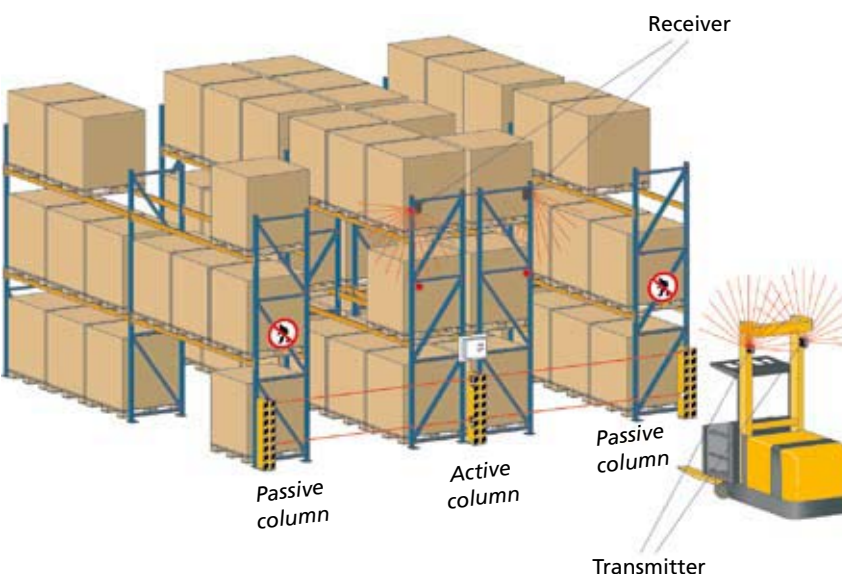

Individual protection



### Mobile personnel protection system (PSS)

Due to their design, the aisles in narrow aisle warehouses are usually so narrow that safety installations are necessary to regulate operations. For safety reasons, an aisle may either contain one fork lift truck or one or more persons at any one time.

The personnel protection system used must be certified to the required safety classification. Persons must not be able to leave the aisle to the side by entering the racking system itself, as it cannot be ruled out that they might then unexpectedly appear in the path of a fork lift truck.

Mobile personnel protection systems or mobile personnel protection systems on the fork lift trucks have proved to be an effective safety measure. These function opto-electronically (e.g. via laser scanners) and detect persons or obstacles in the narrow aisle. The danger is identified in time, and appropriate measures (e.g. stopping the fork lift truck) are initiated, thus preventing accidents.

### Jungheinrich personnel protection system – PSS

The JH-PSS is a contact-free protective device integrated in the truck (performance level in compliance with ISO 13849-1) and meets the requirements of BGV D27, § 28 Par. 2 (formerly VGB accident prevention regulations for fork lift trucks 36, § 28 Par. 2) within the context of access protection in narrow aisles.

The JH-PSS protects personnel where fork lift trucks are operated in narrow aisles with "time-staggered operation" (i.e. where it is prohibited for pedestrians and fork lift trucks to be present in an aisle at the same time). The system also protects collisions between VNA trucks in the aisles when multiple truck operations in aisles is required or necessary.

There are two systems, the "PSS professional" and the "PSS professional plus".

### System description, Jungheinrich PSS

The system consists of two laser scanners, fitted at the front and rear of the truck. The PSS is integrated in the architecture of the JXP backup computer of the fork lift truck. Safe connection to the CAN-Bus is ensured. Control and evaluation are performed via the central vehicle electronics system. Precise route measurement and definition of the truck position are provided via the Jungheinrich transponder technology described above.

### Function test

Each time the vehicle is put into operation, a self-test is automatically performed. All components are checked for correct functioning and reliable switching. The test is carried out before and during travel into the aisle and does not delay operations. If the result of the test is negative, an emergency stop is triggered and the vehicle can then only be moved at creep speed.

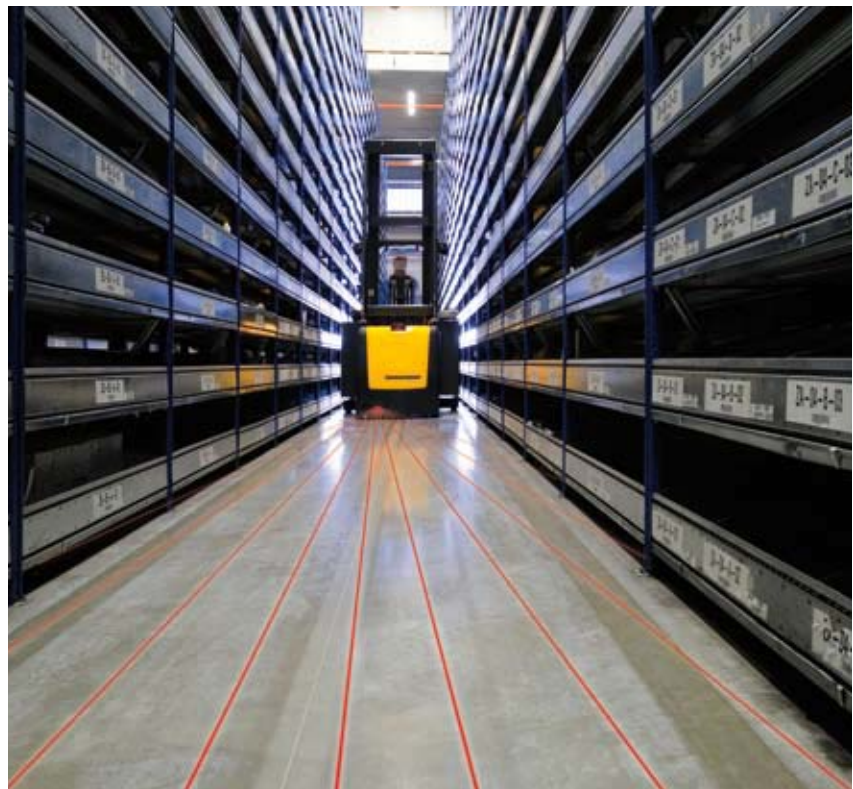

EKS 312 including PSS Professional plus



Protected laser scanner in an EKK 515k

#### Equipment/general information

- High-efficiency scanner for scanning of the irrespective travel path
- System integrated in the JXP backup computer. Delivery ex works
- Operating and display function via the trucks operations control centre (OCC)
- Control and evaluation via the central vehicle electronics system
- Reliable connection via CAN-Bus
- Consistent, TÜV-certified safety protocol
- Complies with performance level as specified by ISO 13849-1

**One-stop design, configuration, delivery, commissioning and maintenance, i.e. just one supplier for the entire package: Jungheinrich truck with PSS.**

#### Functions

- Automatic activation of protective and warning field when the truck enters the aisle, for the detection of obstacles
- Visual and acoustic warning if the protective and warning fields are breached (display in the truck; acoustic message: volume and audio frequency can be parameterised)
- Length of protective and warning fields set according to the individual truck requirements and geometry
- Automatic deactivation of the PSS when the truck leaves the aisle (PSS Professional)
- Reduced speed in load direction if the scanner is covered
- Prevention of undesired lowering of the operator position into the scanning area. Three types of override after triggering of the PSS can be parameterised:
  1. Continued travel at creep speed with override button without limitation
  2. Time-limited continuation of travel at creep speed – maximum 5 seconds
  3. Continuation of travel for a limited distance at creep speed – maximum of one pallet position

#### Additional functions, PSS professional plus

- Parameterisation of up to eight protective and warning fields (also asymmetrical) possible
- Apron monitoring at close range by means of short protective and warning field (driver assistance system)
- Aisle recognition and switchover of protective field for different aisle width
- Speed-dependent switchover of protective and warning field
- Special programming to specific customer requirements is possible on request, in compliance with the relevant standards and guidelines



Laser scanner, Jungheinrich PSS



## Process optimisation.

### Warehouse navigation in narrow aisles.

#### Enhanced performance by integrating trucks into the processes

"You have reached your destination." It achieves this through RFID technology.

#### General

As already described in the Chapter "Floors – structure and requirements," the performance data of high rack stackers have been vastly improved in recent years as a result of AC three phase technology.

The lift speed is now more than 0.5 m/s and the travel speed is 12 km/h. These figures have almost doubled in the last 20 years.

It is highly unlikely that these levels of improvement will be repeated, i.e. the physically acceptable limit has more or less been reached. The trucks of the future will not only have to be powerful performers, they will need to have intelligent technology on-board to interface with the IT systems and integrated them into the logistical processes.

Initially, transponder technology was used for truck management, i.e. ground control and communication with the rest of the warehouse; it therefore governed all the switching functions and speed profiles.

Jungheinrich transponder technology now offers optimum preparation for warehouse navigation. This is based on both the permanent positioning of the trucks and the interfacing of the truck control system with a higher level control system (Warehouse Management Systems).

This system reduces driver fatigue, increases throughput and helps avoid picking and stacking errors.





### System description

“Warehouse navigation” uses the features of transponder technology for navigation and pinpoint approaching of pallet locations. All transport and picking orders are transmitted from the warehouse management system (WMS) to the trucks radio data terminal (RDT). From here, the x, y and z coordinates of the location are received directly by the truck controller via a serial RS232 interface. This enables the truck to identify the respective target location and approach it semi-automatically under driver control. The driver sees the travel and lift directions on the display and when the functions are applied, the truck automatically approaches the position with pinpoint precision.

With optimised diagonal travel for optimum efficiency. When the truck has been positioned, a spotlight (optional) illuminates the picking position and shows the operator on which side and which location he/she should pick from. The truck driver therefore no longer needs to concentrate on things such as:

- approach,
- searching for pallets,
- the “ideal time” to start diagonal travel,
- barcode scans as confirmation for the WMS in the case of combi trucks.

The warehouse navigation does all that for the operator. Incorrect journeys and adjustments are therefore eliminated.

Warehouse navigation:

- In the quickest time
- Over the shortest distance
- With as much energy as required and as little as possible

You can find a template for the calculation of profitability in the Chapter “Process optimisation – Efficiency in the warehouse.” Your specialist system consultant can carry out a calculation based on your specific requirements.



# Advantages of warehouse navigation.

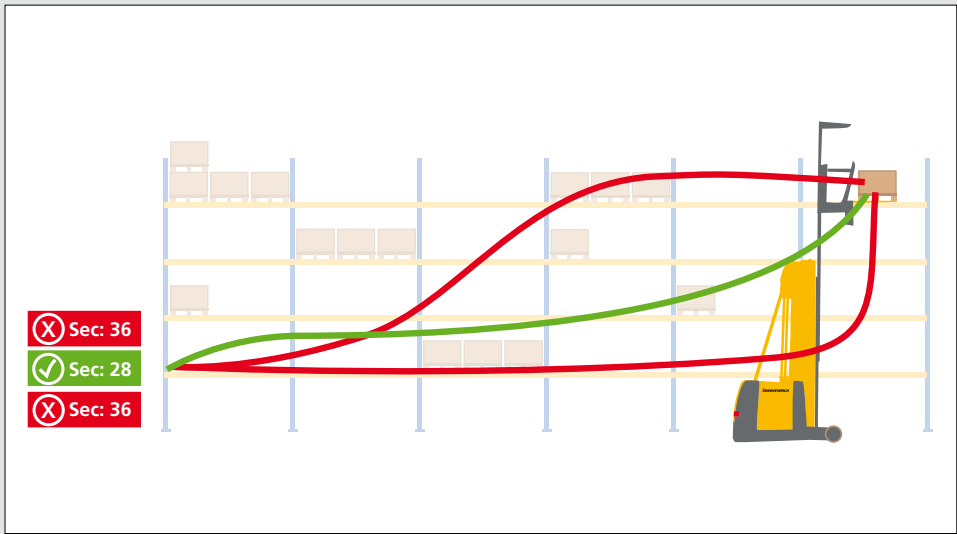

Comparison – EKKX with / without warehouse navigation:

Optimised approach with warehouse navigation allows time savings of up to 25%. The “green curve” proves this: In the shortest time and the shortest distance, with as much energy as required and as little as possible.

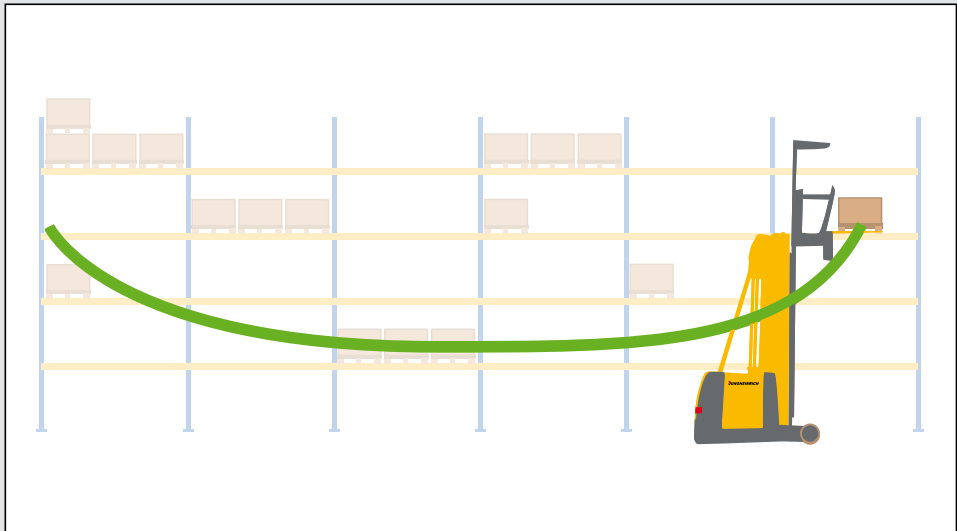

“Intelligent destination approach” of an EKKX with warehouse navigation:

The truck computer calculates the quickest way to the target position. All processes required for positioning, such as travel route, speed for the route, lift start from the route, lift height from the route path and lift start from the target height are performed in an optimised manner via activation of the drive lever.

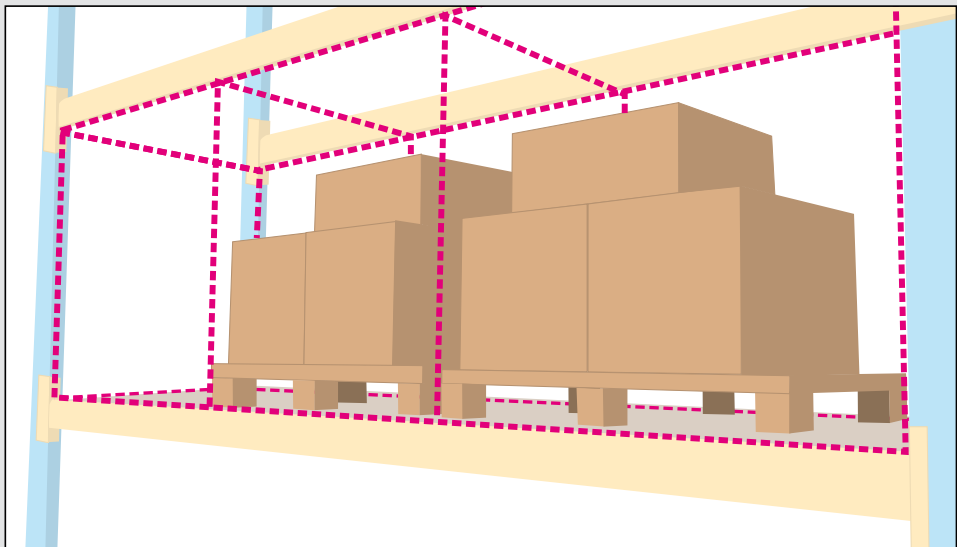

Dynamic warehouse management system:

No matter how the pallets are stored, the warehouse navigation system is aware of this and sends the truck to the correct position every time. Control is via the Warehouse Management System.

## Practical experience.



Greater productivity through EKK high rack stackers with warehouse navigation

### Example: Customer reference

The customer: One of the world's leading logistics service suppliers, CEVA Logistics, specialises in the design, implementation and operation of complex logistics solutions. For medium-sized to large companies on a regional, national and international level.

At Niederaichbach in Lower Bavaria, CEVA Logistics handles the entire logistics chain for filter manufacturer Mann & Hummel.

The initial situation:

- Filters and power units are stored on pallets in an 11 metre high bay warehouse – consisting of 15 aisles and 19,100 pallet locations. Stacking is performed by three EKK combination trucks.
- Stacking and retrieval jobs are transmitted to the truck radio data terminals by a Warehouse Management System (WMS). To achieve a virtual zero percent error rate, pallets, rack and transfer locations are scanned, in some cases several times.
- The warehouse system consists of long rack rows due to restricted warehouse conditions. Searching and scanning costs too much time.
- The theoretical high speed of the trucks cannot be fully utilised. The warehouse efficiency is therefore not ideal.
- The trucks already operated in two shifts; there did not appear to be any room for further improvement in performance.
- Different drivers require different times for stacking and retrieving operations. Searching for pallet locations increases driver fatigue.

### The task for Jungheinrich

- Increase logistic system's efficiency without changing the warehouse system or WMS
- Maintain the very low error rates
- Achieve a standard driver productivity level
- Alleviate driver stress

### EKX high rack stacker with warehouse navigation

RFID transponders in the ground continually supply the trucks with location details. Stacking/retrieval orders received from the WMS are sent via the logistic interface on the truck terminal directly to the truck controller. This means the truck knows the exact position to approach. The driver only has to give the travel and lift commands. The truck approaches the required pallet location to the precise millimetre, performs the stacking/retrieval operations and then confirms the various control stages to the WMS. Fully automatically!



"You have reached your destination" – EKX with warehouse navigation

#### Advantage 1:

Greater productivity throughout the entire logistic system

- Automatic and precise approach of the rack position specified by the WMS along the quickest route. With optimum acceleration and braking – the maximum truck speed can be fully utilised.
- No searching or back-tracking
- No manual scanning for stacking and retrieving

#### Advantage 2:

Very high level of process safety with low error rates

- Automated processes leave less room for error
- Stacking and retrieval operations are always performed at the right positions
- The WMS inventory is always up-to-date

#### Advantage 3:

Easy integration

- Easy integration in the existing warehouse environment through the Jungheinrich logistic interface
- No changes were necessary to the WMS
- No changes were necessary to the warehouse topology





Getting to destination automatically and at full speed

**Advantage 4:**

Improved driver ergonomics matched by greater overall system robustness

- Significantly less strain on the drivers, who no longer have to search for locations
- Relaxed operation as “ancillary jobs” such as searching and scanning no longer apply
- Less rack damage since the forks are automatically positioned at the correct location and height
- The racks do not require labels or such like, which could get contaminated or scratched

**Advantage 5:**

The customer is delighted  
Robert Gruber, Contract Manager at CEVA Logistics, Niederaichbach:  
“My drivers are ‘guided’ through the processes by the warehouse navigation. As a result they are more relaxed while at the same time achieving a consistently high throughput. The pinpoint soft positioning spares both rack and goods. We didn’t have to make any changes to the existing warehouse or software systems. The Jungheinrich team implemented the whole system in a highly professional manner.”

# Warehouse navigation in wide aisles.

With the module "Warehouse navigation for wide aisles," you can also exploit the potential of warehouse navigation for freely manoeuvrable fork lift trucks. The module functions in a manner similar to that used in a navigation system for cars. This boosts the efficiency and safety of processes outside the narrow aisle.

Navigation in wide aisles is very different from that in narrow aisles. As described above, truck location in the narrow aisle warehouse is based on RFID technology and transponders in the warehouse floor. In contrast, navigation in the apron zone and in wide aisles requires a special positioning system, as the trucks are freely manoeuvrable.

The basis for efficient use of the warehouse navigation system in a wide aisle warehouse is the integration of all fork lift trucks in operation into the user's entire process chain – from goods inward/unloading of Lorries to dispatch/loading of Lorries. Wide aisle navigation can simply be set up as a module on various trucks, for example reach trucks, order picking trucks or electric counterbalance trucks.

## Determination of the exact position of the fork lift truck in the wide aisle possible

An optical positioning system is used for navigation in wide aisles. This makes it possible to define the precise position of the fork lift truck at any time. The position can be defined to within just a few centimetres. The basis for this

navigation system is a radio data transmission terminal and the Jungheinrich logistic interface. The latter "translates" the requirements of the warehouse management system into the "truck language" and vice versa.

### Examples of navigation displays – Intuitive recognition and operation

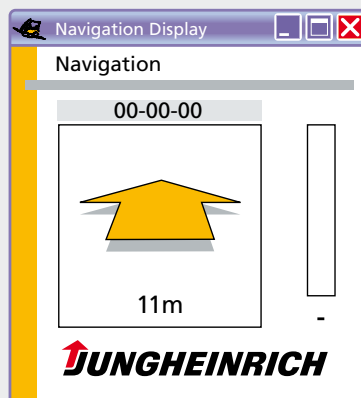

Drive straight ahead, change of direction after 11 metres

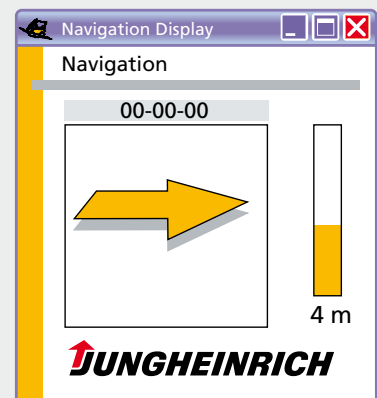

Turn left after 4 metres



Destination reached, in right rack row

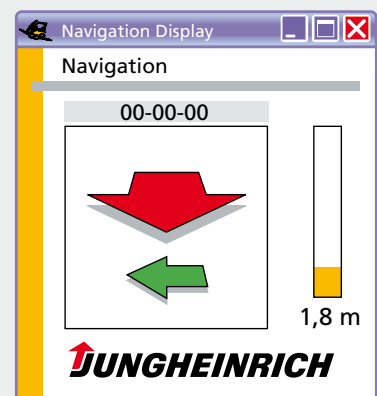

Reverse 1.8 metres, you have overshot your destination

Wide aisle navigation allows the application of various functions. The "Route guide" displays the direction and route, amongst other things, to the driver – like the navigation systems used in cars. For example, if the driver takes a wrong turning, he/she is first informed of this. Then, if he/she drives on, the route is recalculated. The aim is to

ensure that the fork lift truck reaches its destination via the shortest and quickest route. The "Vehicle location" function ensures continuous tracking of the fork lift truck position. Parallel to this, feedback of the truck location to the warehouse management system or a stacker guidance system ensures optimum control of the entire truck fleet.

**What does this mean?  
A significant increase in process reliability through navigation in wide aisles**

As soon as a driver reaches his/her target location, for example a position in the rack aisle and activates the lifting control, the "Rack height select" function allows the lifting frame to be extended to the pallet location defined by the warehouse management system. Additional scanning or confirmation of the location is no longer required.

The route guide, the Rack height select and the automatic confirmation transmitted to the WMS make work much easier for the truck driver. Stacking or retrieval in the wrong aisle or shelf is prevented. The use of warehouse navigation in wide aisle entrances process reliability in warehouse and logistics systems.

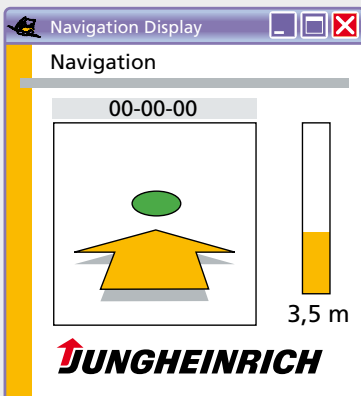

Drive straight ahead, destination after 3.5 metres

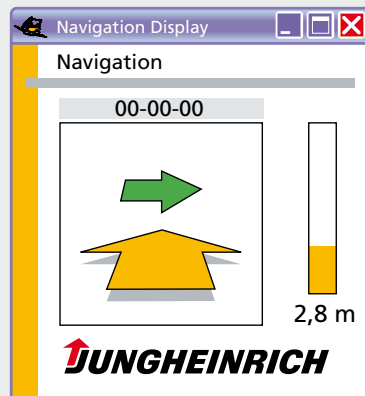

Drive straight ahead, destination after 2.8 metres in right rack row

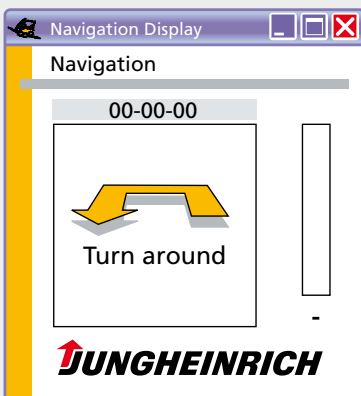

Wrong direction, please turn around

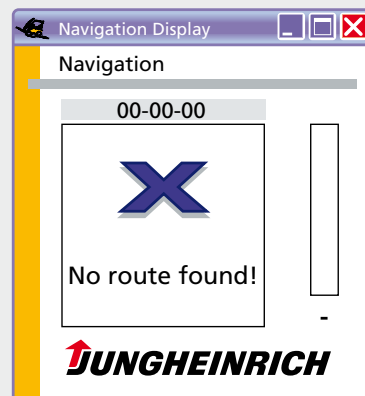

No route found, truck outside defined route

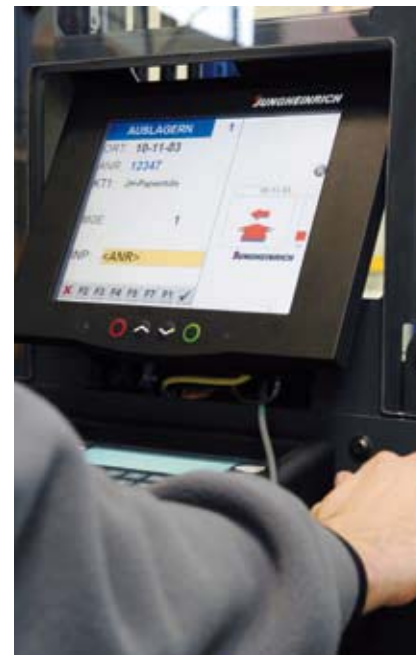

The "Route guide" shows the driver the direction and route



## Radio data transmission.

Radio data transmission and mobile terminals provide warehouse communication that is networked and therefore efficient. All personnel receive their stacking, retrieval and picking orders directly from the WMS, either displayed on their truck or hand-held terminal or announced through headphones via pick-by-voice systems. There is no need for dealing with complicated paper lists. Barcode scanning enables all goods movements to be checked directly by the WMS. All the inventory information is up to date at any given moment as all goods movements are transmitted to the WMS.

### The advantages

- Data in the ERP (Enterprise Resource Planning) and/or WMS systems are kept up to date at all times
- Faster processing with paperless order system
- Happier customers and less returns handling costs due to error reduction
- Can be used in different environments – e.g. cold stores

### Range of services

- Consultancy
- Wireless Local Area Network simulation
- Installation, commissioning and training
- Performance analysis
- Maintenance and service

### Optimum coverage in every warehouse

WLAN simulation before commissioning, performance analysis after commissioning. These two services ensure optimum radio coverage over the entire warehouse area.



**EKG 515 including radio data transmission terminal and scanner, fitted on a railing**

Before commissioning: WLAN simulation. The number and position of the radio access points is simulated on the basis of the warehouse layout and information on the racking and the goods stored.

After installation and commissioning comes performance analysis: radio coverage is tested in actual operation and

the radio data transmission system adjusted as required.

And professional documentation ensures that all results are transparent. Both the WLAN simulation and the performance analysis are integral parts of every radio data transmission project. To ensure that your data keeps flowing, at all times and throughout your system.

# Warehouse Management System.



EKS 312 – Scanning process



EKX 515 – Scanning process

The “Jungheinrich WMS” warehouse management system allows you to control any warehouse: standard pallet warehouses, drive-through/mobile racking warehouses, modular racking systems and fully automatic systems with rack operating and materials handling equipment. All areas of the warehouse (e.g. goods inward, goods outward, reserve areas and picking areas) are administered, the entire material flow controlled and optimised.

The Jungheinrich WMS is a flexible system. It can be adapted to your intralogistics processes through a range of parameters and settings that can be adjusted even during operation. An extensive reporting system and numerous evaluation options ensure complete transparency. The Jungheinrich WMS can be connected to many existing system environments through standard interfaces.

## Range of services

- Consultancy
- Generation of specifications including interface details
- Installation, commissioning and training
- Maintenance and service

# Efficiency in the warehouse.

## Example: Energy

In view of rising costs and climate change, saving energy is an important consideration for the operation of large-scale logistics centres.

In the face of rising energy costs and new requirements such as the energy conversation and energy management, the operators of warehouse installations also need to keep a closer eye on energy efficiency in future when it comes to warehouse planning and management, in order to comply with the new requirements and remain competitive.

The energy consumption of vehicles used in the warehouse is an important factor, and savings of up to 30% can be achieved here without major effort.

### Energy consumption

In order to keep energy consumption at the low level for which they are well-known, Jungheinrich system vehicles are all equipped with:

- AC technology (all motors)
- Regenerative braking + regenerative lowering → effective energy recovery
- High-efficiency hydraulic systems

- Active energy management → low current flow
- Active battery management → low current spikes
- CAN-Bus → 70% fewer cables and plugs

These measures and continued further development of the systems allow significant savings per vehicle to be made. And of course, deployment over two shifts without changing the batteries is thus not a problem.

## What does this mean?

Comparative test: EKX 515 compared to a rival vehicle.

To determine the potential savings for the warehouse operator in €, a Jungheinrich EKX 515 was compared with a vehicle manufactured by a rival company.

## Procedure:

Same warehouse, same performance data for the 80-volt combi fork lift trucks.

Operations were performed using the following criteria, based on VDI 2516:

## Results:

### Warehouse data

- aisle length [m] 65
- top beam/location [m] 14
- working cycle/hour 30
- time/working cycle [s] 93
- pallet weight [t] 1

### Work cycle based on VDI 2516

- operating hours/year 3000
- charging factor 1,15
- electricity price 0.12 €/kWh
- charger efficiency 0.86

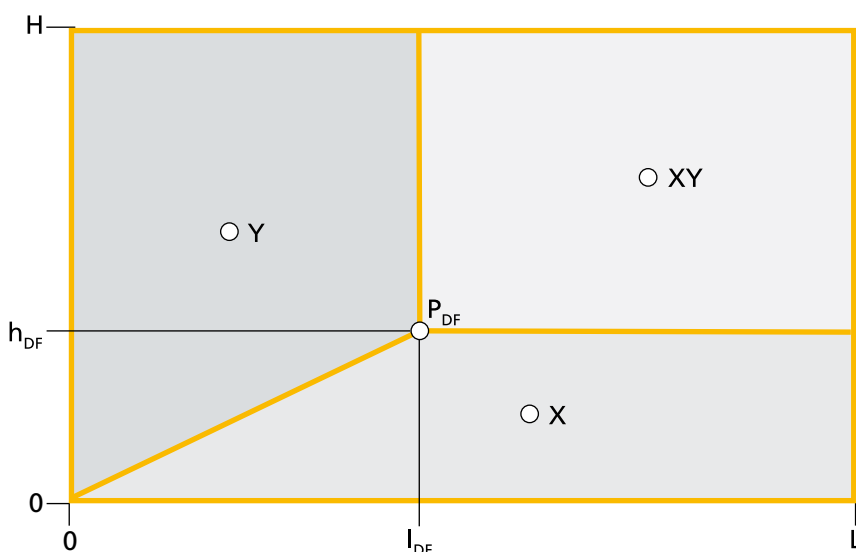

- H maximum stacking height
- L rack length
- l<sub>DF</sub> diagonal travel length
- h<sub>DF</sub> diagonal travel height
- P<sub>DF</sub> point of diagonal travel
- X focus rack area X
- Y focus rack area Y
- XY focus rack area XY

3000 operating hours	EKX 5	competitor
Ah/work cycle	1.5	2.2
Energy consumption kWh/year	16,608	24,359
Energy costs/year	1993 €	2923 €
Emissions CO <sub>2</sub> t/year	10.2	14.6

Without costs for additional batteries and without ABC structure, the cost saving is:

- € 930 per year for 1 truck
- € 18,600 per year for 20 trucks

It should also be noted here that the current spikes on the rival vehicle during diagonal travel reduce the battery lifespan.



**Example: Economic efficiency**

Up to 25 % higher efficiency through warehouse navigation – excerpt from the “programme” for calculation of economic efficiency:

Calculation of economic efficiency for warehouse navigation 1 truck		Sum in €
<b>Investments / financing rates</b>		
Investment sum truck costs		
With warehouse navigation: additional truck costs		
With warehouse navigation: Jungheinrich logistics interface (JH-LI)		
Observation period in years		
Annual service costs		
and/or		
Monthly rental charge (financing + service), truck with terminal		
With warehouse navigation: additional monthly rental charge		
<b>Annual operating costs (excluding energy costs)</b>		
Truck costs		
Gross personnel costs		
Costs for warehouse navigation		
Total costs without warehouse navigation	Result:	
Total costs with warehouse navigation	Result:	
<b>Annual performance</b>		
Service hours		
Double work cycles per hour without warehouse navigation		
Increase in efficiency through warehouse navigation		
Work cycles per year without warehouse navigation	Result:	
Work cycles per year with warehouse navigation	Result:	
Cost per work cycle without warehouse navigation	Result:	
Cost per work cycle with warehouse navigation	Result:	
Cost saving per double work cycle	Result:	
<b>Saving per year</b>	Result:	

**Table for calculation of economic efficiency of a narrow aisle truck with warehouse navigation.  
Please contact your Jungheinrich partner directly for an individual calculation!**

**Example of a reference system:**

The customer: One of the world’s leading logistics service suppliers  
 The initial situation: 11 metre high bay warehouse  
 15 aisles, each 80 metres long, and 19,100 pallet positions  
 Two-shift operation of trucks (2000 operating hours/year)  
 The solution: Warehouse navigation  
 Automatic data transfer from the WMS  
 Semi-automatic approach  
 No scanning processes necessary  
 Work cycles per year without warehouse navigation: 40,000  
 Work cycles per year with warehouse navigation: 50,000  
 Saving per truck/year: € 26,000

# Individual solutions ex works.

## The perfect combination of industrial production and craftsmanship

Developed on the basis of consummate engineering skill, many years of experience – and an understanding of our customers' requirements.

There are many ways of distinguishing yourself – including a professional attitude. Special applications require special system trucks. This applies especially to tasks which are difficult to perform – due to application specific transport operations, complicated warehouse conditions or perhaps unusual goods. Here, quality and cost-effectiveness from series production are combined with personal requirements. The consistent modular design of Jungheinrich system trucks makes this possible.



EKV 515, hydraulically adjustable telescopic fork

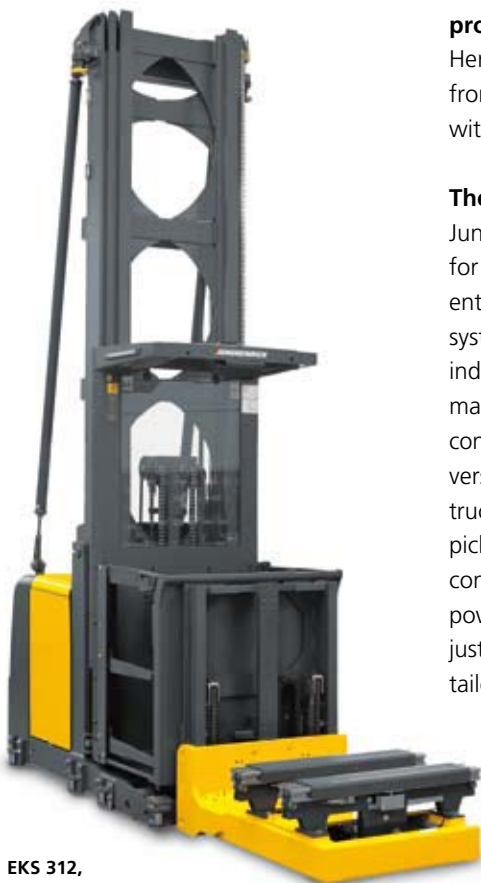

EKS 312, telescopic fork and special mast

## Large-scale series and individual production

Here, quality and cost-effectiveness from series production are combined with personal requirements.

## The modular system

Jungheinrich have just the right vehicle for specific requirements. The consistent modular design of Jungheinrich system trucks makes this possible. With individual chassis lengths and widths, mast designs, offset or split operator consoles, picking cages and trolleys conversion of "combi trucks" to picking trucks, telescopic forks (double or triple) picking platforms in a wide range of configurations, special fork carriages, power collectors on the truck, to name just a few possibilities ... and always tailored to the specific application.

## Flexible software

Designed around functionality. The control system matches the strategy individual software for the requirements of the application. TÜV-certified control system for maximum flexibility and safety. The computer system of all warehouse and system vehicles, which can also be supplied with customised solutions from the factory, consists of two components: a master computer and a backup module. Both components provide a constant exchange of information and monitor each other in a redundancy system. Jungheinrich make no compromises when it comes to individual systems trucks, and have had the system certified by the technical inspection agency TÜV.



EKK 513, telescopic fork with auxiliary lift in front of the fork and emergency escape ladder

### Safety with CE marking

Tested just like series trucks. All options are CE-tested in combination with the vehicle and undergo extensive tests for the intended use. Jungheinrich demonstration trucks are subjected to continuous testing on corresponding test rigs. And it goes without saying that all conformity evaluation procedures specified in the relevant standards are performed, i.e. the technical documentation is provided. There are no problems with spare parts, replacement parts which may be needed at any point in the future. The same modifications can be re-ordered at any time. In addition, Jungheinrich create an individual operating manual for each truck.



EKK 515, split operator consoles and conversion to a picking truck

### Legal background

In the case of conversions, the directives follow from the basic premise that any significant modification of a machine results in the production of a new machine. Any modification which affects safety, in other words, any modification which may lead to increased risk, is considered as significant. If a significant modification is carried out, a new EU Declaration of Conformity needs be produced, on the basis of a risk assessment of the modified vehicle with reference to the scientific and technological state-of-the-art. The entity performing or playing the major role in the modification is considered to be the manufacturer. The EU Declaration of Conformity for the modified machine may only be submitted if the risk assessment has proved that the overall machine complies with the current safety requirements of the Machinery Directive and the Equipment and Product Safety Act.

### Some of the solutions already realised

- offset or split operator consoles
- picking cage and trolleys
- conversion of a "combi truck" to a picking truck
- telescopic forks (double or triple)
- picking platforms in a wide range of configurations
- special fork carriages
- power collectors on the vehicle

### Fully automatic equipment

EKK and ETX for 24-hour operation. Your advantages:

- Increased productivity
- Maximum availability
- Safe handling of goods
- A flexible alternative to rack operating equipment (i.e. Stacker Cranes)
- The level of automation can be increased step by step



### Busbars and onboard chargers

Busbar installations have proven themselves to be highly effective wherever high throughput figures in 2-shift and 3-shift operations are required. The Busbar system supplies 3-phase AC current that is fed into the onboard charger via power collectors. All energy-consuming truck components are supplied with power from the battery which is replenished from the on-board charger. Space and costs are saved through redundant charging stations, external chargers and exchange batteries. Not only are working hours and effort caused by exchanging the heavy batteries saved; but additional resources that have to be taken into account when equipping a charging room are also saved.

### Busbar installation

As a rule, the aisle equipment consists of Busbars installed either on the left or right, entry funnels and power supplies, generally installed at a racking beam level (height level approx. 2–3 m above the floor). The truck must be guided prior to the power collector connecting with the power supply of the Busbar.

### Charger, power supply on the truck

The high rack stackers and order pickers are equipped with a special charger (48 V or 80 V, 80 A, 100 A, 120 A and 150 A) for the travelling whilst charging operation. Different performance characteristics facilitate a "buffer or charging process". Sensors on the truck ensure delayed on and off switching of the charger to avoid contact burning of the power collector during entry and exit of the Busbar. If possible, truck entry into the aisle should only be in

### Enclosed Busbar

The contact between power supply and Busbar is created in the enclosed Busbar within an almost closed U profile. The power supply is fixed to a mobile arm on the truck and is led to the Busbar via the entry funnel.

#### Characteristics:

- optimum protection against contact
- low dirt accumulation in the inner Busbar
- entry funnel within the aisle, no lost space on the apron
- optimum control of power supply vehicle

### Open Busbar

In open systems the power supply contact with the current conductors is created at the front of the Busbar.

#### Characteristics:

- low construction height in the aisle
- more accessible for maintenance and repair



Enclosed conductor rail with current collector

one direction. The power supply collector can also be fixed on both sides. In this case it must be ensured that only the active power supply according to the Busbar position and the entry direction is extended.

Single sided power collectors can be supplied as a simple fixed arm system for mono directional operation in applications with full Busbar systems, alternatively (are preferred) powered pickup

collector arms can be supplied for both single or dual pickup operation in all configurations.

The specially designed power collector adjusts horizontal and vertical tolerances and cushions impacts. In enclosed Busbars, the power supply is provided via a pickup arm that runs within the Busbar profile.



# Enquiry Sheet.

## Busbar option for EKX 4/5 and ETX 5

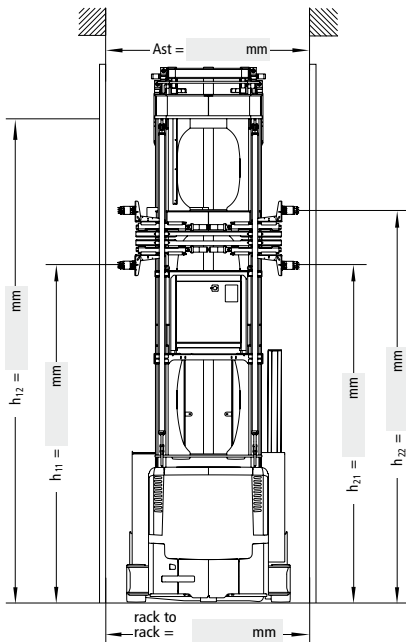

### Type

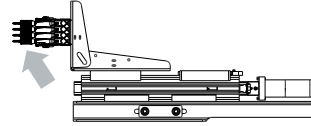

open

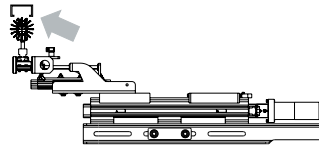

closed

### Supplier

- Vahle   
 Wampfler   
 other

### Desired assembly

- Mast   
 Frame

### Rail guided trucks and Busbar assembly on chassis:

Width rail to rail:  mm

Height of rail profiles:  mm

Clearance between rollers and floor:  mm

- Type of rail profiles: Angle within   
 Angle outside   
 U-Profile   
 other

### Important information

Customer:

Order number:

Voltage:

Frequency:

0 PE/ground: high position  low position  push  pull

Collector: via Transponder  fixed

Charger connected via: Magnet at Busbar  Transponder

Information:

Date:

Confirmed:

### Trucks with "open" Busbar, and also mounted only on one side of the truck:

Collector in Load Direction:

Collector in Drive Direction:

Clearance between Busbar

Inner edge to inner edge of Busbar

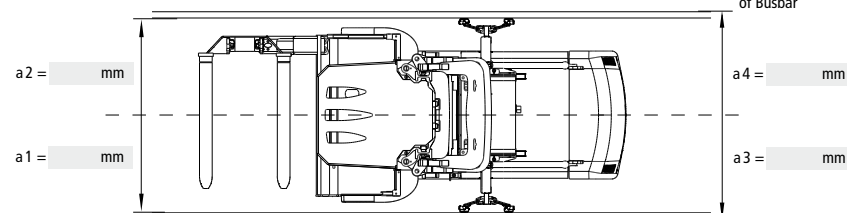

Collector in Load Direction:

Collector in Drive Direction:



## Energy supply.

### Battery charger technology.

The battery and charger technology gives the optimum energy source requirements to maximise the productivity of the truck. Systems can be designed for discharged battery to be recharged on the truck or in a specific battery recharge area.

#### Charging on the truck

There are generally two possibilities:

- The truck is driven to an external charger during operational breaks. The battery is connected to the charger and charged. Appropriate charging stations (if necessary a separate room) must be taken into account during planning.

This system is recommended if trucks are not in continuous operation (e.g. in 1-shift operation).

- The truck is equipped with an onboard charger. Power for charging is supplied via a Busbar in the aisle.

This system is mainly used in 2-shift or 3-shift operations.

#### Charging outside the truck

The discharged battery is removed from the truck and a charged exchange battery is installed. The truck is immediately operational. A sideways battery change is generally planned for narrow aisle trucks. The battery is positioned on a roller bed and secured on the side against rolling off. The exchange is carried out manually (with battery change table/trolley) or with other aids (e.g. an additional truck).

Battery removal via fork pockets on the battery case is also a popular method of battery changing. In this case roller beds are not required at the battery "stands" on its fork pockets.

The battery is charged from an external charger at a charging station or in a separate charging room. Jungheinrich offers battery and charging systems individually specified to your application.

#### High-frequency technology

We strongly advise the use of high-frequency chargers for gentler charging of the batteries. Such chargers correspond to the state-of-the-art and help cut operating costs.

The advantages of HF chargers:

- increased battery lifespan
- preconfigured charging programme
- gentle charging with HF technology and process control
- up to 30% energy savings compared with conventional chargers
- shorter charging times



### Battery charging stations and rooms

The following list comprises a few points which need to be taken into consideration when designing charging locations or rooms, as specified by EN 50 272-3:

- Sufficient dimensioning of traffic routes and areas
- Height of charger room at least 2 metres
- Safety distance of minimum 2.5 metres from inflammable material and stored goods (also with integrated chargers)
- Installation of battery chargers and electric cables on a non-inflammable surface
- Protection for charging cables from mechanical damage (e.g. by pinching or running over)

- Min. distance of 1 metre between batteries and chargers
- Make sure the charger cable is long enough. The standard length is 2.5 metres. Longer cables can be ordered as an option.
- Adequate provisions for installation/ removal and for transporting exchange batteries

A gas mixture of escaping hydrogen and oxygen is created during the battery charging process. With appropriate ventilation of the charging stations or charging rooms (natural or artificial), the gas mixture must be dissipated to such an extent that there is no danger of the lower limit of inflammability being reached.

The design of charging installations is regulated by the following standards:

- EN 50 272-3
- Trade association directives

The operator may need to arrange for an applicable fire protection certification.







# Regulations and standards.

Guidelines / Standard	Description	Page
DIN EN 1726, Part 2	Additional requirements for trucks with elevating operator position and trucks specifically designed to travel with elevated loads	6
DIN 15185, Part 1	Warehouse systems with guided industrial trucks	14
EN 15512	Steel static storage systems – Principles for structural design	18, 21, 27
EN 15620	Steel static storage systems – Tolerances, deformations and clearances	18, 23, 28, 29
EN 15629	Steel static storage systems – Specification of storage equipment	18, 27
EN 15635	Steel static storage systems – Application and maintenance of storage equipment – Adjustable pallet racks – Guidelines for safe use	18, 27, 30
DIN 4102	Fire behaviour of building materials	25
VdS CEA 4001	Verband der Sachversicherer (association of property insurers), design and installation of sprinkler systems	26
EN 206-1	Concrete – Specification, performance, production and conformity	27
DIN 1045-2	Reinforced and prestressed concrete structures	27
DIN 18202	Tolerances in building construction	27, 35, 37
BGR 234	Trade association guideline, storage facilities and equipment	30
DIN 18560	Screeds in building construction	34
IEC 1340-4-1	Electrostatics – electrostatic behaviour of floor coverings and installed floors	34
EN 1081	Resilient floor coverings – Determination of the electrical resistance	34
ISO 6292	Powered industrial trucks and tractors – Brake performance and component strength	34
DIN 1045	Steel and reinforced concrete construction	35
VDMA Guideline	In the narrow aisle area, the VDMA guideline applies: Floor requirements for narrow aisle trucks	35, 36, 37
BetrSichV	Regulations on health and safety at work	38
MRL 2006/42/EG	Machinery Directive	38, 57
DIN 15185, Part 2	Warehouse systems with guided industrial trucks (code of practice for the protection of persons when operating with trucks in narrow aisles)	38, 44, 46
TRBS 2111	Mechanical hazards – General requirements	46
BGV D27	Trade association regulations: accident prevention regulations industrial trucks (formerly accident prevention regulations for fork lift trucks VGB 36)	46
ISO 13849-1	Safety of machinery – Safety-related parts of control systems	46, 47
DIN EN 16001	Energy management systems in practice – A guide for companies and organisations	58
EU Declaration of Conformity	The product may only be marketed in put into operation if it meets the requirements of all applicable guidelines and in as far as evaluation of conformity has been carried out in accordance with all applicable guidelines.	57
GPSG	Equipment and Product Safety Act	61
EN 50 272-3	Safety requirements for batteries and battery systems	61
VDI 2516	Floor conveyors for storage and retrieval – Cycle time calculation in narrow aisles	58
EnEV	Energy conservation ordinance	58

# Check list.

## Actual.

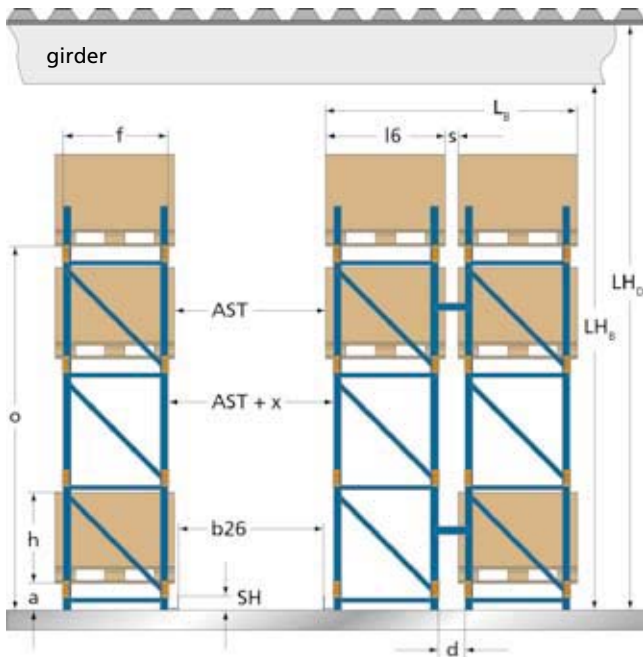

### Pallet

- Pallet length ( $L_6$ ) = \_\_\_\_\_ mm
- Pallet width ( $b12$ ) = \_\_\_\_\_ mm
- Stacking-in depth = \_\_\_\_\_ mm
- Pallet/load height ( $h$ ) = \_\_\_\_\_ mm

### Working aisle

- Clear width between pallet/loads ( $AST$ ) = \_\_\_\_\_ mm
- Clear width between guide rails ( $b26$ ) = \_\_\_\_\_ mm
- Guide rail height ( $SH$ ) = \_\_\_\_\_ mm

### Racking

- Clear width between uprights ( $AST + x$ ) = \_\_\_\_\_ mm
- Upper edge bottom beam ( $a$ ) = \_\_\_\_\_ mm
- Upper edge top beam ( $o$ ) = \_\_\_\_\_ mm
- End frame width ( $f$ ) = \_\_\_\_\_ mm
- Distance between uprights in double rack ( $d$ ) = \_\_\_\_\_ mm
- Width over pallets/loads in double rack ( $L_B$ ) = \_\_\_\_\_ mm
- Bay aperture ( $c$ ) = \_\_\_\_\_ mm

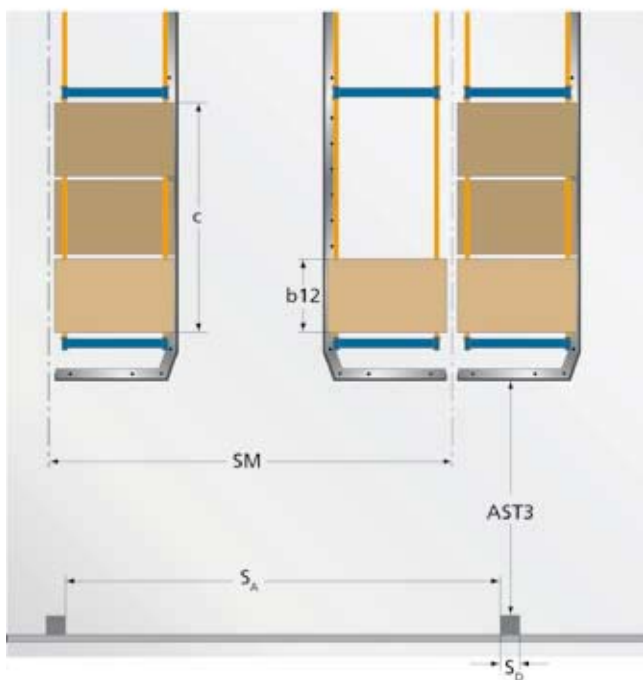

### Building

- Distance between stanchions ( $S_A$ ) = \_\_\_\_\_ mm
- Width of stanchions ( $S_D$ ) = \_\_\_\_\_ mm
- Transfer aisle width ( $AST3$ ) = \_\_\_\_\_ mm
- Clear height under truss ( $LH_B$ ) = \_\_\_\_\_ mm
- Clear height under roof ( $LH_D$ ) = \_\_\_\_\_ mm
- Module dimension ( $SM$ ) = \_\_\_\_\_ mm



## The Complete Solution.

### The benefits that Jungheinrich can offer.

- The complete solution: from the initial material flow consultation via planning, design, co-ordination and organisation of all logistics equipment during implementation right up to project handover.
  - Jungheinrich will also be there after the operational go-live with our extensive network of fully trained service engineers.
  - In many cases Jungheinrich works as the main contractor. Advantages to you: a contact partner who co-ordinates all equipment and has overall responsibility throughout the entire project.
  - Professional project management methods are used during the project – so that everything runs according to plan and on time.
  - Behind the main Jungheinrich contact, stands a team of experienced specialists in the areas of material flow analysis, project management, simulation, warehouse administration and truck control.
  - Direct lines of communication: Customer – Jungheinrich Project Leader – Jungheinrich Project team. Therefore, direct, efficient decision making processes leading to effective implementation.
  - Over 50 years of Jungheinrich experience. We develop the optimum solution for each application individual requirements.
- Planning and optimisation of flexible, multifunctional and efficient solutions**
- Manual, semi and fully automated systems
  - Integration in existing IT systems
  - Adjustable and scaleable solutions
  - Short payback periods
  - Short to medium term planning objectives
  - Optimum space utilisation with high storage provision
  - Excellent Project Management processes to deliver the solution





Jungheinrich  
Plants, Sales and  
Services Europe  
ISO 9001/ISO 14001



Jungheinrich trucks  
conform to the European  
Safety Requirements.

### **Jungheinrich UK Ltd.**

Head Office:  
Sherbourne House  
Sherbourne Drive  
Tilbrook  
Milton Keynes MK7 8HX  
Telephone 01908 363100  
Fax 01908 363180

info@jungheinrich.co.uk  
www.jungheinrich.co.uk

  
**Machines. Ideas. Solutions.**