

TECHNICAL SHEETS FOR COORDINATION

VERTICAL RECOMMENDATION FOR USE SHEETS (RfUs) Status in October 2023

Number CNB/M/ (¹)	Revision (Rev)	Key words	Approved by Vertical Group of NBs ⁽²⁾ on:	Approved by Horizontal Committee of NBs ⁽²⁾ on:	Endorsed by Machinery Expert Group/MWG on:
Vertical Group 01 – Woodworking machinery					
01.029	05	Tractor driven machine, P.T.O.	24/04/2009	09/12/1998	03/03/2000
01.089	03	Electric and electronic brakes, run-down time, failure of power supply	21/05/2014	18/06/2014	08/01/2015
01.092	02	Single blade edging circular rip sawing machines with power driven saw unit and manual loading and/or unloading	31/03/2021	16/12/2021	23/03/2023
Vertical Group 02 – Meatworking machinery					
02.001	02	Adjustable guards	17/11/2011	13/12/2011	23/04/2012
Vertical Group 03 – Presses for the cold working of metals					
03.002	15	Presses – Metal – Field of application	30/09/2009	12/12/1995	04/06/1996
03.004	06	Technical file	30/09/2009	12/12/1995	04/06/1996
03.005	03	Platform, ladders	30/09/2009	17/04/1996	08/06/1998
03.013	08	Acceptability of components of type examined presses	13/10/2010	14/12/2010	23/05/2011
03.022	06	Intrinsic safe pneumatic valve	30/09/2009	18/09/1997	08/06/1998
03.027	09	Secondary protection / Two Hands Control Device / Active Optoelectronic Protective Devices	19/09/2019	14/06/2022	23/03/2023
03.028	06	Failing of springs in the brake	30/09/2009	18/09/1997	08/06/1998
03.029	04	Reaching over, under and around the detection zone	30/09/2009	12/12/1995	04/06/1996
03.032	07	Fixing the tools, failure of one component	24/05/2022	14/06/2022	23/03/2023
03.035	07	Crushing hazards, ram frame	24/05/2022	14/06/2022	23/03/2023
03.102	06	Overrun detection / Screw presses	30/09/2009	09/06/2005	29/10/2005
03.111	09	Stopping time measurement / die cushion / ejector	12/09/2019	14/06/2022	23/03/2023
03.124	07	Press-brakes / tandem assembly	29/09/2009	21/11/2005	20/04/2006
03.128	08	Overlapping, Monitoring Valves	29/09/2009	09/06/2005	29/10/2005
03.141	04	Bypassing monitored restraint valves	29/09/2009	02/06/1999	03/03/2000
03.143	09	Spindle / Screw presses – block / shoe brakes	12/10/2010	14/12/2010	23/05/2011
03.154	07	Hydraulic presses, Mechanical restraint device, Production and Maintenance	30/09/2009	24/10/2002	02/03/2004
03.157	05	Press-Brake, Hydraulic Press, Release of trapped persons	29/09/2009	09/06/2005	29/10/2005
03.159	06	Valve monitoring, PES	29/09/2009	24/10/2002	02/03/2004
03.160	05	Automatic cycle - AOPD / Interlocking guard without guard locking valve monitoring	29/09/2009	04/12/2001	04/01/2005
03.162	09	AOPD - Press Brakes	20/03/2007	-	21/04/2015

Number CNB/M/ (1)	Revision (Rev)	Key words	Approved by Vertical Group of NBs⁽²⁾ on:	Approved by Horizontal Committee of NBs⁽²⁾ on:	Endorsed by Machinery Expert Group/MWG on:
03.164	06	Press Brakes – Mode selection	29/09/2009	16/06/2003	17/12/2003
03.165	05	Press Brakes, Light curtains-Blanking	29/09/2009	16/06/2003	17/12/2003
03.166	06	Press Brakes, AOPD	29/09/2009	16/06/2003	17/12/2003
03.170	05	Hydraulic Presses with “Low force approach” – Controls	29/09/2009	16/06/2003	17/12/2003
03.172	04	Safety valve, separated clutch and brake	29/09/2009	16/06/2003	17/12/2003
03.176	05	Restart / Reset / AOPD	29/09/2009	09/06/2005	29/10/2005
03.177	04	Hydraulic press brake – AOPD moving with the beam, box bending, mode confirmation	30/09/2009	09/12/2004	24/05/2005
03.179	04	Press-brakes – Working with one side guard open	29/09/2009	09/12/2004	24/05/2005
03.180	04	Press-brakes – Ancillary devices – Powered tools clamping devices	28/09/2009	09/12/2004	24/05/2005
03.182	04	Press-brakes – ESPE using AOPD in the form of laser beams – Additional crushing hazard	28/09/2009	09/12/2004	24/05/2005
03.185	05	Movable screens	30/09/2009	09/06/2005	29/10/2005
03.186	06	Acceptability of a component, configurable or parameterizable PES	28/09/2009	26/11/2009	26/05/2010
03.187	05	Failure of auxiliary powered functions for setting	30/09/2009	09/06/2005	29/10/2005
03.188	06	Front guard switch	28/09/2009	10/08/2008	08/01/2009
03.189	05	Defeat of protective measures on presses	30/09/2009	21/11/2005	20/04/2006
03.192	04	Press brakes – secondary working devices	06/10/2008	09/12/2008	18/06/2009
03.193	06	Servo Press (Power Presses & Press Brakes), Muting, Slow Speed / Directional Monitoring	03/03/2009	10/06/2009	31/01/2018
03.194	05	Servo press (Power Presses & Press Brakes), brake	03/03/2009	10/06/2009	25/12/2009
03.196	04	Servo presses, protective measures	07/10/2008	09/12/2008	18/06/2009
03.200	05	Servo-presses (Power Presses & Press Brakes), Stopping performance monitoring	03/03/2009	10/06/2009	25/12/2009
03.201	05	Servo-presses (Power Presses & Press Brakes), STO, prevention of unintended start	04/03/2009	10/06/2009	25/12/2009
03.202	04	Press brakes – back gauge movement initiation	03/03/2009	10/06/2009	25/12/2009
03.204	03	Presses – Safety distances	28/09/2011	11/12/2012	04/06/2013
03.206	03	Presses – Two hand control device (THCD)	27/09/2012	11/12/2012	04/06/2013
03.207	03	Press-brakes – Powered work-piece supports	27/09/2012	11/12/2012	04/06/2013
03.209	03	Hydraulically actuated clamps	26/09/2013	10/12/2013	31/01/2018
03.210	04	Servo press-brake connection between motor and screw	24/09/2015	02/12/2015	23/09/2016
03.211	02	Press-brakes – Powered work-piece supports	26/09/2014	24/06/2015	23/09/2016
03.214	04	Press brake / Control panel /	12/09/2019	14/06/2022	23/03/2023

Number CNB/M/ (1)	Revision (Rev)	Key words	Approved by Vertical Group of NBs ⁽²⁾ on:	Approved by Horizontal Committee of NBs ⁽²⁾ on:	Endorsed by Machinery Expert Group/MWG on:
		Wireless			
03.216	04	Presses with a servo drive system (mechanical servo presses); brakes	24/05/2022	14/06/2022	23/03/2023
03.217	02	Reset function	12/09/2019	14/06/2022	23/03/2023

Vertical Group 04 – Injection or compression moulding machines

04.034	05	Rubber and Plastics injection moulding machine; interlocking of movable guards providing access to the closing mechanism area	25/08/2009	02/12/1999	09/04/2001
04.053	07	24 VDC hydraulic valves, protective bonding circuit connection on the voltage supply plug of a 24 VDC solenoid valve	09/06/2021	16/12/2021	23/03/2023
04.076	06	Plastics and rubber hydraulic IMM – horizontal mould closing movement – motor control unit	09/06/2021	16/12/2021	23/03/2023
04.083	07	Injection machines with tie bar distances >1200 mm; person standing behind the mould at the rear side of the machine or entering the mould area from the operator's side	03/05/2022	14/06/2022	23/03/2023
04.085	07	Mould opening for machines with horizontal closing movement and electrical axis	03/05/2022	14/06/2022	23/03/2023
04.086	07	Electrical axis; guards locking, detection standstill	03/05/2022	14/06/2022	23/03/2023
04.087	06	Plug and socket combinations for subunits on injection moulding machines	03/05/2022	14/06/2022	23/03/2023

Vertical Group 05 – Machines for underground work

05.001	05	Internal combustion engine, emission of dust, gas, exhaust	03/11/2009	07/12/2000	04/01/2005
05.002	05	Internal combustion engine, emission of dust, gas, exhaust, methane in intake air	03/11/2009	07/12/2000	04/01/2005
05.007	04	Internal combustion engine, emission of dust, gas, exhaust, limits	03/11/2009	07/12/2000	04/01/2005
05.201	03	Hydraulic powered roof support	03/11/2009	13/12/1995	04/06/1996
05.202	02	Hydraulic powered roof support, components with safety function, safety components	03/11/2009	13/12/1995	04/06/1996
05.208	03	Hydraulic powered roof support, placing on the market, putting into service	03/11/2009	12/12/1995	04/06/1996
05.220	05	Hydraulic powered roof support, support unit, technical file, EC-type examination	03/11/2009	07/12/2000	04/01/2005
05.221	04	Hydraulic powered roof support, single props	03/11/2009	07/12/2000	04/01/2005
05.222	04	Hydraulic powered roof support, pressure supply, EC-type examination	03/11/2009	07/12/2000	04/01/2005

Number CNB/M/ (1)	Revision (Rev)	Key words	Approved by Vertical Group of NBS⁽²⁾ on:	Approved by Horizontal Committee of NBS⁽²⁾ on:	Endorsed by Machinery Expert Group/MWG on:
05.601	05	Locomotive, EC-type examination, running test	03/11/2009	07/12/2000	04/01/2005
05.603	05	Locomotive, EC type examination certificate, putting into operation, control	03/11/2009	07/12/2000	04/01/2005
05.604	05	Locomotive, definition	03/11/2009	07/12/2000	04/01/2005
05.801	02	Machines for tunnels	03/11/2009	12/12/1995	25/03/1997
Vertical Group 06 – Refuse collection vehicles					
06.005	05	Calculations	15/04/2010	11/03/1997	08/06/1998
06.012	06	Automatic lifting device-operation mode	15/04/2010	10/06/2008	08/01/2009
06.034	10	Refuse collection vehicle (RCV) - rear footboard	15/04/2015	24/06/2015	23/09/2016
06.047	02	Danger zone / Visibility / testing	02/06/2021	16/12/2021	23/03/2023
Vertical Group 08 – Vehicle servicing lifts					
08.001	04	Polyamide Nuts	12/04/2010	13/12/1995	04/06/1996
08.002	04	EC type test	12/04/2010	09/12/1998	03/03/2000
08.003	05	Instruction handbook, check	12/04/2010	09/12/1998	03/03/2000
08.008	03	Auxiliary lifting systems	12/04/2010	17/04/1996	08/06/1998
08.015	03	Rails foot protectors, protection against pinching points	12/04/2010	11/12/2003	01/07/2004
08.016	03	Chassis supporting vehicle lift for road vehicles, load distribution	12/04/2010	11/12/2003	01/07/2004
08.018	05	Load distribution on two post lifts with load-bearing arms	25/04/2013	26/06/2013	22/11/2013
08.023	03	Maximum inclination of pickup plates and pads	08/06/2021	16/12/2021	23/03/2023
08.024	04	Welding examination	21/12/2021	14/06/2022	23/03/2023
08.025	03	Structural Calculations	31/05/2022	14/06/2022	23/03/2023
Vertical Group 09 – Lifting Persons Device (LPD)					
09.206	04	Lifting Persons Device (LPD), Suspended Access Equipment, modular construction, certification	13/04/2010	11/12/2003	14/03/2007
09.207	10	Type-examination	13/04/2010	26/11/2009	26/05/2010
09.209	04	EC type-examination, work platform, loader crane	13/04/2010	11/12/2003	01/07/2004
09.305	06	Mobile Elevated Workplatform (MEWP), levelling system	13/04/2010	11/06/1998	09/04/2001
09.306	05	Mobile Elevated Workplatform (MEWP), levelling system	13/04/2010	11/06/1998	09/04/2001
09.307	04	Lifting Persons Device, safety gear	13/04/2010	24/05/2000	09/04/2001
09.309	04	Mobile Elevated Work Platform, MEWP, access, movable guard, abnormal use	13/04/2010	24/05/2000	09/04/2001
09.310	05	Man rider winches, one rope suspension	13/04/2010	24/05/2000	09/04/2001
09.318	07	Crushing hazards, ram frame	12/06/2015	29/06/2016	23/03/2023
09.401	08	MEWP, control devices, emergency stop, override	13/04/2010	11/12/2003	01/07/2004
09.501	05	Radiation, EC type- examination, EMC directive	13/04/2010	24/05/2000	09/04/2001
09.502	02	Lifting platforms, lifts, gripping device/safety gear, tripping	01/06/2015	29/06/2016	23/03/2023

Number CNB/M/ (1)	Revision (Rev)	Key words	Approved by Vertical Group of NBs ⁽²⁾ on:	Approved by Horizontal Committee of NBs ⁽²⁾ on:	Endorsed by Machinery Expert Group/MWG on:
		device / overspeed governor, safety device, lifting persons			
Vertical Group 11 – Safety components					
11.017	05	EC type-examination, pre-standards	25/10/2010	11/06/1998	09/04/2001
11.027	08	Two-hand control devices, synchronous actuation	25/10/2010	14/12/2010	23/05/2011
11.031	09	ESPE Type 2 with PLC as means of periodic test	25/10/2010	14/12/2010	23/05/2011
11.032	05	Arrangement of visual indicators	25/10/2010	03/03/2004	24/12/2004
11.033	09	-	22/05/2019	16/12/2021	23/03/2023
11.035	08	Indication of a muted ESPE, colour of the mute indicator(s) of an ESPE	25/10/2010	14/12/2010	23/05/2011
11.036	07	Laser scanner, industrial truck	25/10/2010	14/12/2010	23/05/2011
11.042	04	THCD, non-mechanical actuating devices	25/10/2010	21/11/2005	20/04/2006
11.047	03	Using parts with wear-out in safety components	11/05/2010	15/06/2010	30/12/2010
11.049	03	Logic units to ensure safety functions / Environmental conditions	25/10/2010	14/12/2010	23/05/2011
11.050	05	Failure, electromechanical outputs	06/06/2013	26/06/2013	22/11/2013
11.052	02	Safety components, safety functions	18/10/2011	13/12/2011	23/04/2012
11.053	03	Manual reset function	10/05/2012	28/06/2012	17/01/2013
11.054	03	Safety components, instructions	06/06/2013	26/06/2013	22/11/2013
11.055	04	Cogeneration plants, combined heat and power plants (CHP), grid monitoring	02/06/2014	17/06/2014	08/01/2015
11.056	03	Two-hand control devices, synchronous actuation, operating conditions	07/06/2013	26/06/2013	22/11/2013
11.058	03	Safety component, warning device	07/06/2013	26/06/2013	22/11/2013
11.059	03	Diagnostic functions, EN 61508:2010	03/06/2014	17/06/2014	08/01/2015
11.060	06	External DC power supply of safety component, PELV, abnormal voltage	22/05/2019	16/12/2021	23/03/2023
11.061	06	RFID-based protective devices	02/06/2015	29/06/2016	31/01/2018
11.062	04	Pressure-sensitive protective device, sensor, control unit, OSSDs, definition	09/06/2015	02/12/2015	23/09/2016
11.065	03	AOPD, type	01/06/2017	07/06/2017	31/01/2018
11.067	03	Testing, witness testing, remote testing of safety components and logic unit	22/01/2021	16/12/2021	23/03/2023
11.068	02	AOPDDR, IP protection class	22/01/2021	16/12/2021	23/03/2023
11.069	02	Transformers	14/09/2021	16/12/2021	23/03/2023
Vertical Group 12 – ROPS and FOPS					
12.007	05	DLV	21/11/2013	10/12/2013	15/04/2014
12.009	05	Minor modification	21/11/2013	10/12/2013	15/04/2014
12.010	05	FOPS, Standing operator	21/11/2013	10/12/2013	15/04/2014

Number CNB/M/ (1)	Revision (Rev)	Key words	Approved by Vertical Group of NBS⁽²⁾ on:	Approved by Horizontal Committee of NBS⁽²⁾ on:	Endorsed by Machinery Expert Group/MWG on:
12.012	07	ROPS	21/11/2013	10/12/2013	15/04/2014
12.015	05	ROPS, FOPS, repair, substitution	21/11/2013	10/12/2013	31/01/2018
12.016	02	FOPS, tiltable cab	21/11/2013	10/12/2013	15/04/2014

Vertical Group 13 – Full quality assurance

13.000	03	Equivalence to Annex IX	21/08/2008	09/12/2008	18/06/2009
13.001	04	Final inspection, quality management, intermediate inspections	17/09/2007	10/06/2008	08/01/2009
13.002	07	quality system, compliance with standards, accreditation	26/08/2010	14/12/2010	23/05/2011
13.003	04	Application, quotation, selection of Notified Body	17/09/2007	10/06/2008	08/01/2009
13.004	04	Manufacturer, sub-contractors, conformity, supplier, subsidiaries	17/09/2007	10/06/2008	08/01/2009
13.005	04	Representative model, categories of machinery, risks	17/09/2007	10/06/2008	08/01/2009
13.006	02	EC declaration of conformity, technical file	17/09/2007	04/12/2007	04/06/2008
13.007	03	Technical file, assessment on site, quality system	17/09/2007	04/12/2007	04/06/2008
13.008	02	Complete technical file, documentation, complex machinery, audit	17/09/2007	04/12/2007	04/06/2008
13.009	04	Quality system documentation, quality management manual, certificates, audit reports, language	17/09/2007	10/06/2008	08/01/2009
13.010	04	Technical design specification, sample, manufacturing facilities, inspections, audit plan	17/09/2007	10/06/2008	08/01/2009
13.011	04	Harmonized standards, responsibility, design review	17/09/2007	10/06/2008	08/01/2009
13.012	05	Design inspection, design verification, independence, level of confidence	23/10/2012	10/06/2008	08/01/2009
13.013	03	Product complexity, validation, competence	17/09/2007	04/12/2007	04/06/2008
13.014	04	Competency qualification of personnel, product specific requirements	17/09/2007	10/06/2008	08/01/2009
13.015	04	Machinery design, quality, compliance	17/09/2007	10/06/2008	08/01/2009
13.016	05	Existing certification, conformance, certified quality system	23/10/2012	10/06/2008	08/01/2009
13.017	02	Auditors, experts, competence	17/09/2007	04/12/2007	04/06/2008
13.018	02	EHSR, technical file, review	17/09/2007	04/12/2007	04/06/2008
13.019	04	Product changes, changes of quality system, significant changes, contract	17/09/2007	10/06/2008	08/01/2009
13.020	04	Notification, report, certificate	17/09/2007	10/06/2008	08/01/2009
13.021	04	Audit frequency and duration, surveillance audits	17/09/2007	10/06/2008	08/01/2009
13.022	02	Unannounced visits, contracts	17/09/2007	04/12/2007	04/06/2008
13.023	04	Obligation to preserve	12/05/2009	10/06/2009	25/12/2009
13.024	04	Obligation to preserve, quality	17/09/2007	10/06/2008	08/01/2009

Number CNB/M/ (1)	Revision (Rev)	Key words	Approved by Vertical Group of NBs⁽²⁾ on:	Approved by Horizontal Committee of NBs⁽²⁾ on:	Endorsed by Machinery Expert Group/MWG on:
		assurance system documentation			
13.025	04	Last date of manufacture	17/09/2007	10/06/2008	08/01/2009
13.026	02	audit frequency and duration, assessment	17/09/2007	04/12/2007	04/06/2008
13.028	03	technical file, sample, manufacturing facilities, inspections, audit plan	17/09/2007	10/06/2008	08/01/2009
13.029	03	Subcontract	21/08/2008	09/12/2008	18/06/2009
13.030	03	Reassessment	21/08/2008	09/12/2008	18/06/2009
13.031	04	Annex X	12/05/2009	10/06/2009	25/12/2009
13.033	04	Quality system, audit plan	23/10/2012	09/12/2008	18/06/2009
13.034	04	Certificate	12/05/2009	10/06/2009	25/12/2009
13.035	04	Annex X	12/05/2009	10/06/2009	25/12/2009
13.037	03	Surveillance, quality system, technical file	12/05/2009	10/06/2009	25/12/2009
Vertical Group 14 – Portable cartridge-operated fixing and other impact machinery					
14.001	03	Bolt setting devices, Cattle stunners, other hand held cartridge operated fixing and impact machinery	11/12/2013	18/06/2014	08/01/2015

(1): CNB/M/xx.xxx RERev yy = Coordination of Notified Bodies/Machinery/Numbering of the RfUs
R: Recommendation for Use E: English version Rev: Revision yy: index of the Revision

(2): NBs = Notified Bodies

	CO-ORDINATION OF NOTIFIED BODIES Machinery Directive 2006/42/EC as amended RECOMMENDATION FOR USE		CNB/M/01.089 Revision 03 Language : EN
Number of pages : 1	Date : 21/05/2014	To be approved by :	Approved on :
Origin : VG1 Woodworking machinery		x Vertical Group..... x Horizontal Committee..... To be endorsed by: x Machinery Working Group.....	21/05/2014 18/06/2014 Endorsed on : 08/01/2015
Question related to : 2006/42/EC	Article :	Other : -	
Annex : IV	ESR (1): 1.2.6	Normative clause : -	Other clause : -
Key words : Electric and electronic brakes, run-down time, failure of power supply			
<p>Clause 1.2.6 of the machinery directive 2006/42/EC states: The interruption, the re-establishment after an interruption or the fluctuation in whatever manner of the power supply to the machinery must not lead to dangerous situations.</p> <p>More and more machines for wood working have electric or electronic brakes for the tool drive motor. Most of these brakes do not work without power supply. When there is a failure in the power supply during normal operation, the tool spindle is non-braked and the run-down time may be much higher than the acceptable run-down time outlined in the specific machine standard (mostly 10 s). E. g. on single spindle molding machines non-braked run-down times of several minutes may be possible with large and heavy tools.</p> <p>Note: <i>The same situation occurs, if the stop is performed in stop category 0 due to a failure in the logic of an electronic brake.</i></p> <p>Question:</p> <p>a) Is the situation as described above acceptable or is a fall-back solution for power supply failures, e. g. mechanical brake or braking by UPS or energy recuperation necessary to achieve the required run-down time?</p>			
<p>Solution :</p> <p>Note: <i>No further regulation is necessary, if tool access is prevented by fixed or moveable interlocked guards with guard locking (as far as locking needs power supply to be opened). On the other hand there are many Annex IV woodworking machines having only adjustable guards in some sections of the non-cutting part and no guarding at all for the cutting part of the tool. Only for these machines with unguarded access to the tool and which usually require a braked run-down time of not more than 10 seconds, the following applies.</i></p> <p>The risk assessment by CEN/TC 142/WG 1 and CENELEC/TC 116 lead to the conclusions that</p> <ul style="list-style-type: none"> - the probability of an accident due to uncontrolled run-down of tools after a failure in the energy supply of the machine is extremely low (low probability of uncontrolled run-down and low probability of deliberate access to tools at the same time) - the possible damage is high - the resulting risk is very low and thus acceptable. <p>The situation is <u>acceptable</u> since power supply failure is a seldom and specific situation that can be managed by the operator. He/she is aware of the dangerous situation and will handle any further manipulation on the machine with care.</p> <p>In order to reduce the risk, one or more warning labels in close proximity to the danger zone(s) stating that tool brake(s) may not operate effectively in the case of power supply failure should be required.</p> <p>Note: <i>A failure in the brake device logic is even more seldom. The standards in TC 142 require a stop category 0 (without braking) in this situation. Any further regulation for this situation is not reasonable.</i></p>			

(1) Essential safety regulations

Note: According to point 6.6 of the Guide of the implementation of directives based on the New Approach and the Global Approach, the notified bodies apply as general guidance this recommendation for use.

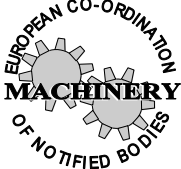
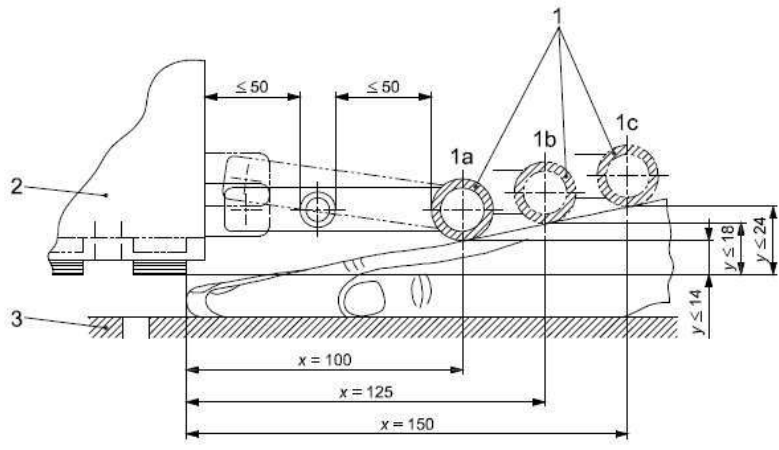
	CO-ORDINATION OF NOTIFIED BODIES Machinery Directive 2006/42/EC + amendments RECOMMENDATION FOR USE		CNB/M/01.092 Revision 02 Language: EN
Number of pages: 2	Date: 03.07.2023	To be approved by:	Approved on:
Origin: VG1 Woodworking Machinery		<input checked="" type="checkbox"/> Vertical Group 1 <input checked="" type="checkbox"/> Horizontal Committee To be endorsed by: <input checked="" type="checkbox"/> Machinery Expert Group	Approved on: 31.03.2021 16.12.2021 Endorsed on: 23.03.2023
Question related to: Directive 2006/42/EC	Article: 1.3.8	EN/prEN: EN 1870-8:2012	Other: -
Annex: IV	EHSR (1): -	Normative clause: 5.3.8	Other clauses: -
CEN TC concerned: CEN/TC 142 (ISO/TC 39)			
Key words: Single blade edging circular rip sawing machines with power driven saw unit and manual loading and/or unloading			
<p>Current situation:</p> <p>EN 1870-8: 2012 defines in clause 5.3.8, paragraph 1 and 2, the following requirement for a trip bar:</p> <p>Where powered workpiece clamping is provided by a pressure beam, the pressure beam shall meet the following requirements:</p> <p>a) it shall be positioned between the sectional safety curtains;</p> <p>b) it shall only operate when the sectional safety curtain is in its lowest position;</p> <p>c) it shall operate a maximum of 1 s after the sectional safety curtain has reached its lowest position.</p> <p>Where the machine is equipped with a work piece clamping device, a trip bar shall be provided on the operator's side of the pressure beam, and at the rear side of the pressure beam if operator access is not prevented.</p>			
<p style="text-align: right;">Dimensions in millimetres</p>  <p>Key</p> <p>1 trip bar 2 pressure beam 3 sectional safety curtain</p>			
Figure 1 - Trip bar dimension			
<p>Woodworking machines according to EN 1870-8 are for cutting solid wood. With lengths of 6 m this leads to considerable height differences (workpieces can be concave, convex, twisted). This can cause this trip bar to respond before the safety curtain has been completely lowered. For this reason, this protective device is sometimes unsuitable for specific applications.</p>			
<p>Question:</p> <p>Are there alternative ways to safeguard the clamping devices on these machines?</p>			

Solution:

An alternative way of safeguarding the clamping device works as follows:

1. The pressure beam shall be positioned between the sectional safety curtains.
2. The pressure beam shall touch the workpiece or the table not less than 2 s after the safety curtain's lower edge.
3. The pressure beam shall reach the clamping pressure before the sawing cycle is started.
4. The machine movement shall be controlled by a 3-position-switch (e.g. position switch acc. IEC 60947-5-8, foot pedal / *foot beam acc. IEC 60947-5-1) with the following characteristics:
 - Upper position: Stops the sawing cycle and releases clamping (all units return to the rest position).
 - Middle position: Starts and controls the sawing cycle.
 - Lower position: Stops the sawing cycle and releases clamping (all units return to the rest position).
 - The force to trigger a foot pedal / foot beam to the lowest position shall be between 100N and 200N.
 - The safety functions to start and stop the sawing cycle and to return the units in a safe position shall achieve $PLr = c$.
 - The clamping pressure monitoring shall achieve $PLr = b$.

*foot beams shall meet the requirements for foot pedals, they shall only differ in width.

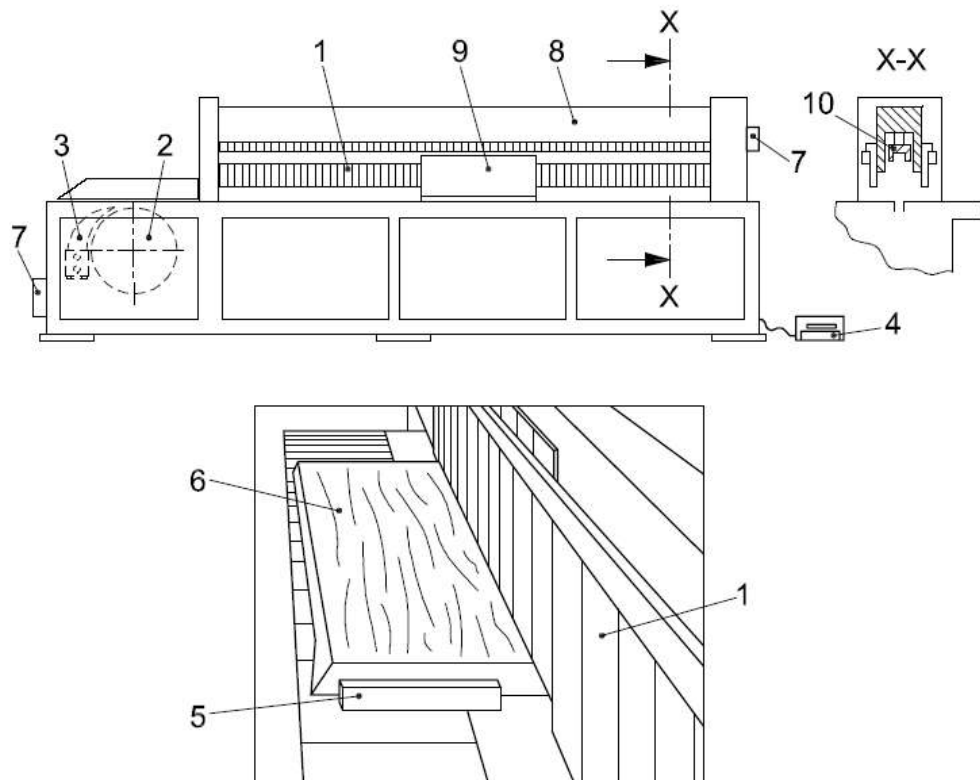

Key

- | | |
|----|--|
| 1 | sectional safety curtain |
| 2 | saw blade in rest position |
| 3 | riving knife |
| 4 | foot-pedal |
| 5 | workpiece end stop |
| 6 | workpiece |
| 7 | extraction outlet |
| 8 | sectional safety curtain support |
| 9 | front deterring/impeding device (on machines with raising and lowering of the saw unit at alternative positions) |
| 10 | workpiece clamping device (pressure beam) (optional) |

(1) Essential safety requirement

Note: According to point 6.6 of the Guide of the implementation of directives based on the New Approach and the Global Approach, the notified bodies apply as general guidance this recommendation for use.

	<p>CO-ORDINATION OF NOTIFIED BODIES Machinery Directive 2006/42/EC + Amendment</p> <p>RECOMMENDATION FOR USE</p>	<p>CNB/M/03.002 Revision: 15 Language: E</p>
<p>Date of first stage: 24/09/1996</p> <p>Origin: VG3 Presses for cold working metals</p>	<p>To be approved by:</p> <p><input checked="" type="checkbox"/> Vertical Group</p> <p><input checked="" type="checkbox"/> Horizontal Committee.....</p> <p>To be endorsed by:</p> <p><input checked="" type="checkbox"/> Machinery Working Group.</p>	<p>Approved on:</p> <p>30/09/2009</p> <p>12/12/1995</p> <p>Endorsed on:</p> <p>04/06/1996</p>
<p>Question related to: Dir. 2006/42/EC Article:</p> <p>Annex: IV-9 EHSR (1):</p>	<p>EN/prEN:</p> <p>Normative clause:</p> <p>CEN TC concerned:</p>	<p>Other:</p> <p>Other clause:</p>
<p>Key words: Presses - Metal - Field of application</p>		
<p>Question: Which categories of metal presses are referred to in Annex IV A, point 9, of the "machines"?</p>		
<p>Recommended Solution:</p> <p>1) By cold working it is understood that there is a possibility of the operator placing (loading) and/or removing (unloading) workpieces between the tools with his hands.</p> <p>2) By metal, it is understood to be a material, either in sheet, rolled conditions, or forged form. Powders, not necessarily metallic, irons, and concrete meshes are excluded from this definition.</p> <p>3) By cold metal working it is understood to be a transformation process either by folding, stamping, or cutting, etc.</p> <p>Only presses who's movable working parts are driven by an alternative movement having the two following constructional characteristics are referred to:</p> <ul style="list-style-type: none"> - a travel of greater than 6 mm, - a closing speed superior to 30 mm/sec. (see CNB/M/3/042) <p>Regarding mechanical presses, the instantaneous speed reached by the movable working parts at the mid-point of their travel during their ascent and descent should be taken into consideration, as it is maximum in either of these positions.</p>	<p>4) exclusion from annex IV A for the machines who's principal purpose is:</p> <ul style="list-style-type: none"> - sheet metal cutting by guillotine (guillotine shears), - attaching a fastener, e. g. riveting, stapling or stitching, fastening etc...(erection, dismantling machines), - assembling e. g. bearing (simple assembling presses), - bending or folding (bending machines, bending presses), - calibrating, - straightening (straightening presses, planing presses), - turret punch pressing (punching and nibbling machines), - extruding (extruder presses), - drop forging or drop stamping, - compaction of metal powder (presses for compacting powders), - punching (punching machines), - blow forging (blow forging presses), - isostatic forming (isostatic presses for metal powder, for complex parts of sheet material) <p>Note 1: Hot working of metals is understood if the operator is forced to use tongs or grippers etc. for handling of hot metals (workpieces) so that his hands are outside of the tools area and cannot be injured.</p> <p>Note 2: If hot metals (workpieces) are placed or removed by hand between the tools without ancillary devices, it is understood as cold working of metals.</p>	
<p>Adaptation procedure: FORMAL ADAPTATION IN CONFORMITY WITH DIRECTIVE 2006/42/EC</p>		

(1) Essential health and safety requirement

Note: According to point 6.6 of the Guide of the implementation of directives based on the New Approach and the Global Approach, the notified bodies apply as general guidance this recommendation for use.

	CO-ORDINATION OF NOTIFIED BODIES Machinery Directive 2006/42/EC + Amendment RECOMMENDATION FOR USE	CNB/M/03.004 Revision: 06 Language: E
Date of first stage: 13/12/1995	To be approved by:	Approved on:
Origin: VG3 Presses for cold working metals	<input checked="" type="checkbox"/> Vertical Group <input checked="" type="checkbox"/> Horizontal Committee.....	30/09/2009 12/12/1995
Question related to: Dir. 2006/42/EC Article: Annex: VI point 2 EHSR (1):	EN/prEN: Normative clause: CEN TC concerned:	Other: Other clause:
Key words: Technical file		
Question: What shall be the contents of a press technical file?		
Solution: The content of the technical file is defined by annex VI point 2 of the directive. It may particularly understand : <u>1st dash</u> (related to the annex VI point 2 about the technical file) - Dimensions of the machine related to the protective means (general drawings with dimensions of accesses to the dangerous parts), - Location diagram of the electrical components on the press (in the cabinet, on the frame...) - Location diagram of the hydraulic and pneumatic components <u>2nd dash</u> - Functional schemes of the control circuits (hydraulic, electric, pneumatic, mechanic...), - Description of the time sequences, e.g. functional characteristics of the valves - Diagrams for cams, selector switches, - A components list with data sheets and instructions for use of certified safety components. - Drawings of the guards (dimensions, material, cams, attachments...), - Drawings of the power flow related to the safety (flywheel, slide, piston, ejectors, handling devices...), - Positioning of the controls (selector switches, emergency stops, pedal...), - Positioning of the guards and the protective devices to check the possibilities of accesses, - Calculations or references about experiences with well tried components..., (see separate technical sheet n° ...) - Declaration of conformity for safety components. - Notes, results, tests (for example stopping time) - Declaration of conformity with the EMC directive from the 1 st /01/96 (see CNB/M/006/R and CNB/M/3/021/R) - Declaration of conformity with the low voltage directive from the 1 st /01/97 (see CNB/M/3/067/R) - Declaration of conformity with others related directives concerning hazardous aspects		

(1) Essential safety requirement

Note: According to point 6.6 of the Guide of the implementation of directives based on the New Approach and the Global Approach, the notified bodies apply as general guidance this recommendation for use.

3rd dash

As parts of the risk assessment, the designer shall verify whether the list of hazards in table 1 of Pr EN692, 693, ... is exhaustive and applicable to the press under consideration.

If additional hazard is identified the risk assessment has to be carried out and the measures taken to eliminate or reduce this risk shall to be described

4st dash

Recommendation for the handbook:

- Where the protective means are described, the associated safety instructions shall be also given and highlighted.

It shall be, at least, one clause containing safety instructions, with reference to the description of the protective devices.

- The instruction handbook may give additional information.

5st dash

See technical sheet CNB/M/00.240/R/E (03.003).

**Adaptation procedure: FORMAL ADAPTATION IN CONFORMITY WITH
DIRECTIVE 2006/42/EC**

	CO-ORDINATION OF NOTIFIED BODIES Machinery Directive 2006/42/EC + Amendment RECOMMENDATION FOR USE	CNB/M/03.013 Revision 08 Language: E
Date of first stage: 13/10/1997	To be approved by:	
Origin: VG3 Presses for cold working metals	<input checked="" type="checkbox"/> Vertical Group <input checked="" type="checkbox"/> Horizontal Committee	Approved on: 13/10/2010 14/12/2010
		To be endorsed by: <input checked="" type="checkbox"/> Machinery Working Group....
Question related to: Directive 2006/42/EC	Article: 5	Other:
Annex: IX	ESR (1):	Other clause:
Key words: Acceptability of components of type examined presses		
Question: If a: - two hand control device - active opto-electronic protective device - cyclic moving interlocking guard - rotary cam gear - control system - overrun detection - etc is examined within a EC Type-Examination of a press, should the results be respected and accepted by other notified bodies testing other presses (also of other press manufacturers) in relation to the above mentioned components ?		
Solution: Normally not. However, if there are separate certificates for single components, the following shall be taken in consideration : 1 - Certificates of notified bodies for safety components, established in Annex IV, shall be accepted by notified bodies for presses. 2 - Certificates of accredited Test and Certification bodies for (safety) components may be accepted by notified bodies for presses. Notes : - The notified body examining a press should have all the necessary technical data for installation and operation of the component. - This RfU is valid only for the safety components assessed under machinery Directive.		

(1) Essential safety requirement

Note: According to point 6.6 of the Guide of the implementation of directives based on the New Approach and the Global Approach, the notified bodies apply as general guidance this recommendation for use.

	CO-ORDINATION OF NOTIFIED BODIES Machinery Directive 2006/42/EC + amendments RECOMMENDATION FOR USE		CNB/M/03.027 Revision: 09 Language: EN
Number of pages: 1	Date: 03.07.2023	To be approved by:	Approved on:
Origin: VG3 Presses for cold working metals		<input checked="" type="checkbox"/> Vertical Group <input checked="" type="checkbox"/> Horizontal Committee To be endorsed by: <input checked="" type="checkbox"/> Machinery Expert Group	19.09.2019 14.06.2022 Endorsed on: 23.03.2023
Question related to: Directive 2006/42/EC	Article: - Annex: I EHSR (1): 1.2.2	EN/prEN: EN ISO 16092-1:2018 Normative clause: 5.3.2.14 CEN TC concerned: CEN/TC143 + ISO/TC39 SC10	Other: - Other clause: -
Key words: Secondary protection / Two Hands Control Device / Active Optoelectronic Protective Devices			
Question: If a large press is safeguarded by light curtains and the tools area has to be entered by operators, which can be a sufficient protection? Normally, the table height is less than 750 mm, sometimes zero. Considering the recommended solution, may a single push button with reset function be an acceptable level of protection?			
Solution: Yes, if there is a good visibility of the dangerous area form the resetting point. Otherwise the following measures have to be adopted: <ol style="list-style-type: none"> 1. The light curtain can act here only as a secondary protection measure to protect third persons. 2. Each operator has to use a two hand control device (THCD) type IIIC to initiate the stroke. 3. Each two hand control device requires a synchronous operation, the THCD's one with another require only simultaneous operation. <p>After an interruption of the light curtain, during the dangerous movement, the reset function has to be actuated before further movement can be initiated as described above.</p>			

(1) Essential health and safety requirement

Note: According to point 6.6 of the Guide of the implementation of directives based on the New Approach and the Global Approach, the notified bodies apply as general guidance this recommendation for use.

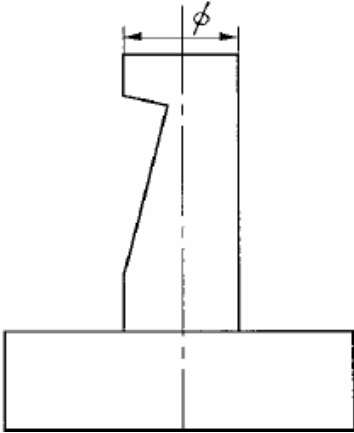
	CO-ORDINATION OF NOTIFIED BODIES Machinery Directive 2006/42/EC + amendments RECOMMENDATION FOR USE		CNB/M/03.032 Revision: 07 Language: EN
Number of pages: 1 Origin: VG3 Presses for cold working metals	Date: 03.07.2023	To be approved by: <input checked="" type="checkbox"/> Vertical Group <input checked="" type="checkbox"/> Horizontal Committee To be endorsed by: <input checked="" type="checkbox"/> Machinery Expert Group	Approved on: 24.05.2022 14.06.2022 Endorsed on: 23.03.2023
Question related to: Directive 2006/42/EC Annex: I	Article: - EHSR (1): 1.3.2	EN/prEN: EN ISO 16092-1:2018 Normative clause: 5.3.3.1 CEN TC concerned: TC 143 and ISO TC 39/SC 10	Other: - Other clause: -
Key words: Fixing the tools, failure of one component.			
Question: Sometimes, single components are used to fix the tool (rod, latch, screw). Which requirements a single component has to fulfil? (see illustration)			
Solution: One screw with a nut for blocking up will be sufficient if well-tried principles according to EN ISO 13849-2:2012 are considered (over-dimension, etc..). 			

(1) Essential health and safety requirement

Note: According to point 6.6 of the Guide of the implementation of directives based on the New Approach and the Global Approach, the notified bodies apply as general guidance this recommendation for use.

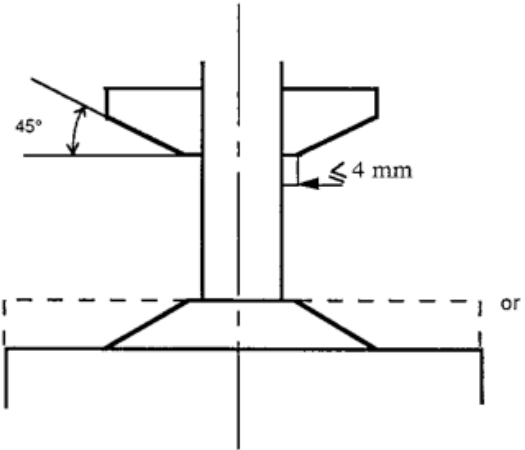
	CO-ORDINATION OF NOTIFIED BODIES Machinery Directive 2006/42/EC + amendments RECOMMENDATION FOR USE		CNB/M/03.035 Revision: 07 Language: EN
Number of pages: 3 Origin: VG3 Presses for cold working metals	Date: 03.07.2023	To be approved by: <input checked="" type="checkbox"/> Vertical Group <input checked="" type="checkbox"/> Horizontal Committee To be endorsed by: <input checked="" type="checkbox"/> Machinery Expert Group	Approved on: 24.05.2022 14.06.2022 Endorsed on: 23.03.2023
Question related to: Directive 2006/42/EC Annex: I	Article: - EHSR (1): 1.3.8	EN/prEN: EN ISO 16092-3:2018 Normative clause: 5.6 CEN TC concerned: TC 143 and ISO TC 39/SC 10	Other: - Other clause: -
Key words: crushing hazards, ram frame.			
Question: Small hydraulic presses often create a crushing hazard between the frame (bottom of the cylinder) and the ram. Which method is appropriate to avoid the hazard?			
Solution: See attached figures 1 to 5 and table 1 of standard EN ISO 13854:2020. If the head can be inserted, the distance shall be equal or more than 300 mm. <div style="text-align: center;">  </div> <p style="text-align: center;">Figure 1</p>			

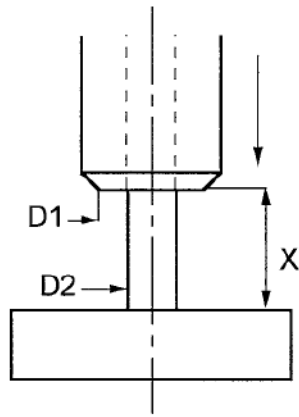

Figure 2

	D1 - D2	• 6 mm	X • 6 mm
6 mm <	D1 - D2	• 25 mm	X • 25 mm
25 mm <	D1 - D2	• 100 mm	X • 100 mm
100 <	D1 - D2	mm	X • 100 mm

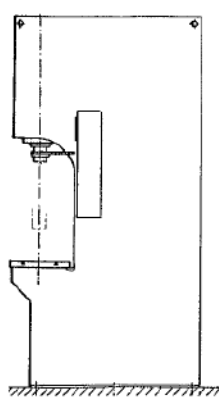
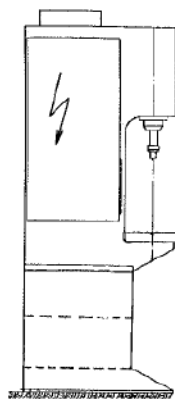
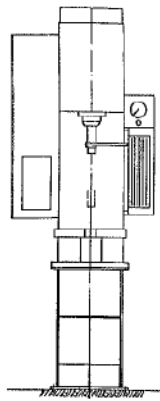

Figure 3

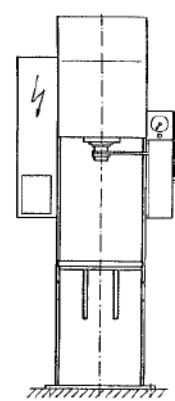

Figure 4

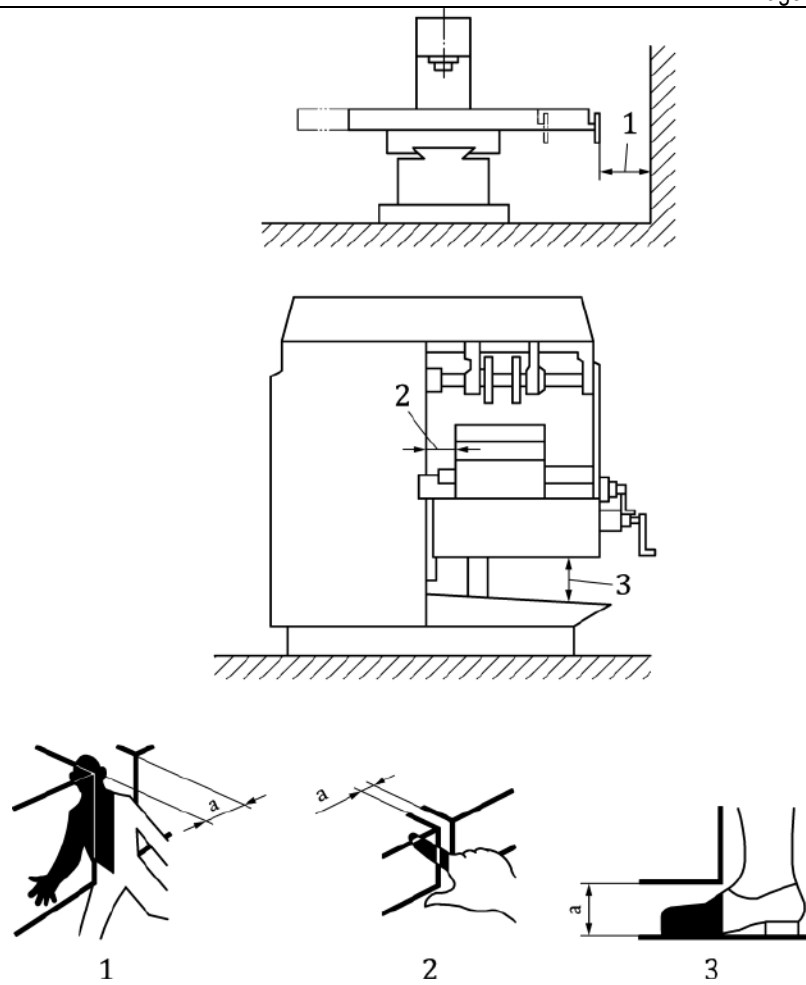



Fig.5 (fig. A.1 from EN ISO 13854)

(1) Essential health and safety requirement

Note: According to point 6.6 of the Guide of the implementation of directives based on the New Approach and the Global Approach, the notified bodies apply as general guidance this recommendation for use.

	CO-ORDINATION OF NOTIFIED BODIES Machinery Directive 2006/42/EC + amendments RECOMMENDATION FOR USE		CNB/M/03.111 Revision: 09 Language: EN
Number of pages: 1 Origin: VG3 Presses for cold working metals	Date: 03.07.2023	To be approved by: <input checked="" type="checkbox"/> Vertical Group <input checked="" type="checkbox"/> Horizontal Committee To be endorsed by: <input checked="" type="checkbox"/> Machinery Expert Group	Approved on: 12.09.2019 14.06.2022 Endorsed on: 23.03.2023
Question related to: Directive 2006/42/EC Annex: I	Article: - EHSR (1): 1.3.8.2, 1.4.1, 1.4.3	EN/prEN: EN ISO 16092-3:2018 Normative clause: Cl. 6, Table 3 CEN TC concerned: CEN/TC143 + ISO/TC39 SC10	Other: - Other clause: -
Key words: Stopping time measurement / die cushion / ejector			
Question: Will a stopping time measurement be required for die cushions or ejectors?			
Solution: No, not in general, but the risk assessment shall take into consideration if the measurement is needed or not. At the present time, the current standards do not require stopping time measurements for die cushions or ejectors.			

(1) Essential health and safety requirement

Note: According to point 6.6 of the Guide of the implementation of directives based on the New Approach and the Global Approach, the notified bodies apply as general guidance this recommendation for use.

	CO-ORDINATION OF NOTIFIED BODIES MACHINERY DIRECTIVE 2006/42/EC + Amendment RECOMMENDATION FOR USE		CNB/M/03.128 Revision 08 Language: E
Date of first stage: 28/09/1998	To be approved by:		Approved on:
Origin: VG3 Presses for cold working metals	<input checked="" type="checkbox"/> Vertical Group <input checked="" type="checkbox"/> Horizontal Committee To be endorsed by: <input checked="" type="checkbox"/> Machinery Working Group		29/09/2009 09/06/2005 Endorsed on: 29/10/2005
Question related to: Dir. 2006/42/EC	Article:	EN/prEN: EN 693:2001 EN 12622:2001	Other: EN 954-1:1996
Annex: I	EHSR (1): 1.2.1	Normative clause:	Other clause:
CEN TC concerned: TC 143 WG 1			
Key words: Overlapping, Monitoring Valves			
Question :			
1.) Which positive overlapping of a (safety related) directional valve can be considered as proper? 2.) Have measures to be taken to test the position monitoring of valves? 3.) Is a binary output of the position monitoring of a proportional valve required or is an analogous output also acceptable?			
Answer :			
1.) The positive overlapping of a directional valve (e.g. restraint valve) shall ensure that the closing speed cannot exceed 1 mm/s as long as the directional valve is in resting position. The positive overlapping of a proportional valve should be bigger or equal than 0,35 mm. The positive overlapping of other directional valves should be equal or bigger than 0,5 mm. Manufacturing tolerances of the parts of the directional valve have to be taken into account. 2.) Measures to check the position monitoring of valves are not required. (The electronics of a position monitoring must conform to – at least- category B of EN 954-1.) The Change of signal must be monitored. 3.) An analogue output of the position monitoring of a proportional valve is acceptable. (The electronics of the position monitoring of a valve must conform to category B of EN 954-1.)			
Remark: If the protection for the operator is raised during the closing stroke all safety related valves must be separated from the electrical energy supply by opening contacts (except the gap between the tools does not exceed 6 mm).			
Note: Good experience have been made with a positive overlapping of a proportional valve equal or more than 0,35 mm and of a directional valve equal or more than 0,5 mm			
Adaptation procedure: FORMAL ADAPTATION IN CONFORMITY WITH DIRECTIVE 2006/42/EC			

(1) Essential health and safety requirement

Note: According to point 6.6 of the Guide of the implementation of directives based on the New Approach and the Global Approach, the notified bodies apply as general guidance this recommendation for use.

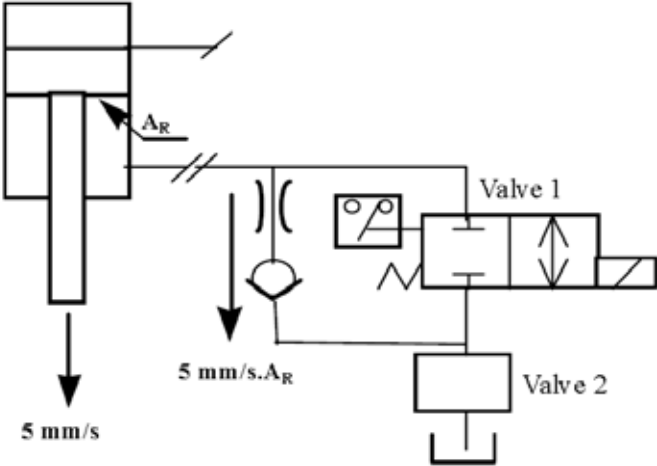
	CO-ORDINATION OF NOTIFIED BODIES MACHINERY DIRECTIVE 2006/42/EC + Amendment RECOMMENDATION FOR USE	CNB/M/03.141 Revision 04 Language: E
Date of first stage: 24/05/2000	To be approved by:	Approved on:
Origin: VG3 Presses for cold working metals	<input checked="" type="checkbox"/> Vertical Group..... <input checked="" type="checkbox"/> Horizontal Committee To be endorsed by: <input checked="" type="checkbox"/> Machinery Working Group.	29/09/2009 02/06/1999 Endorsed on: 03/03/2000
Question related to: Dir. 2006/42/EC Article: Annex: I EHSR (1): 1.2.1	EN/prEN: EN 693:2001+A1:2009 Normative clause: 5.4 CEN TC concerned: TC 143	Other: Other clause:
Key words: Bypassing monitored restraint valves		
Question: Under which conditions bypassing a restraint valve is allowed?		
Solution: 1) The volume flow in the bypass shall be restricted to the value of $5 \text{ mm/s} \times A_R$ (ring area) of the cylinder, e.g. by a bleed (orifice plate) 2) The check valve in the bypass can fail without any detection (see figure) 3) If the second restraint valve fails also, the speed (leakage speed) of the beam/slide/ram shall not increase more than 5 mm/s (check valve failed already without detection) Note: The max. weight of slide/ram/beam with tools has to be taken into consideration		
		
Adaptation procedure: FORMAL ADAPTATION IN CONFORMITY WITH DIRECTIVE 2006/42/EC		

(1) Essential health and safety requirement

Note: According to point 6.6 of the Guide of the implementation of directives based on the New Approach and the Global Approach, the notified bodies apply as general guidance this recommendation for use.

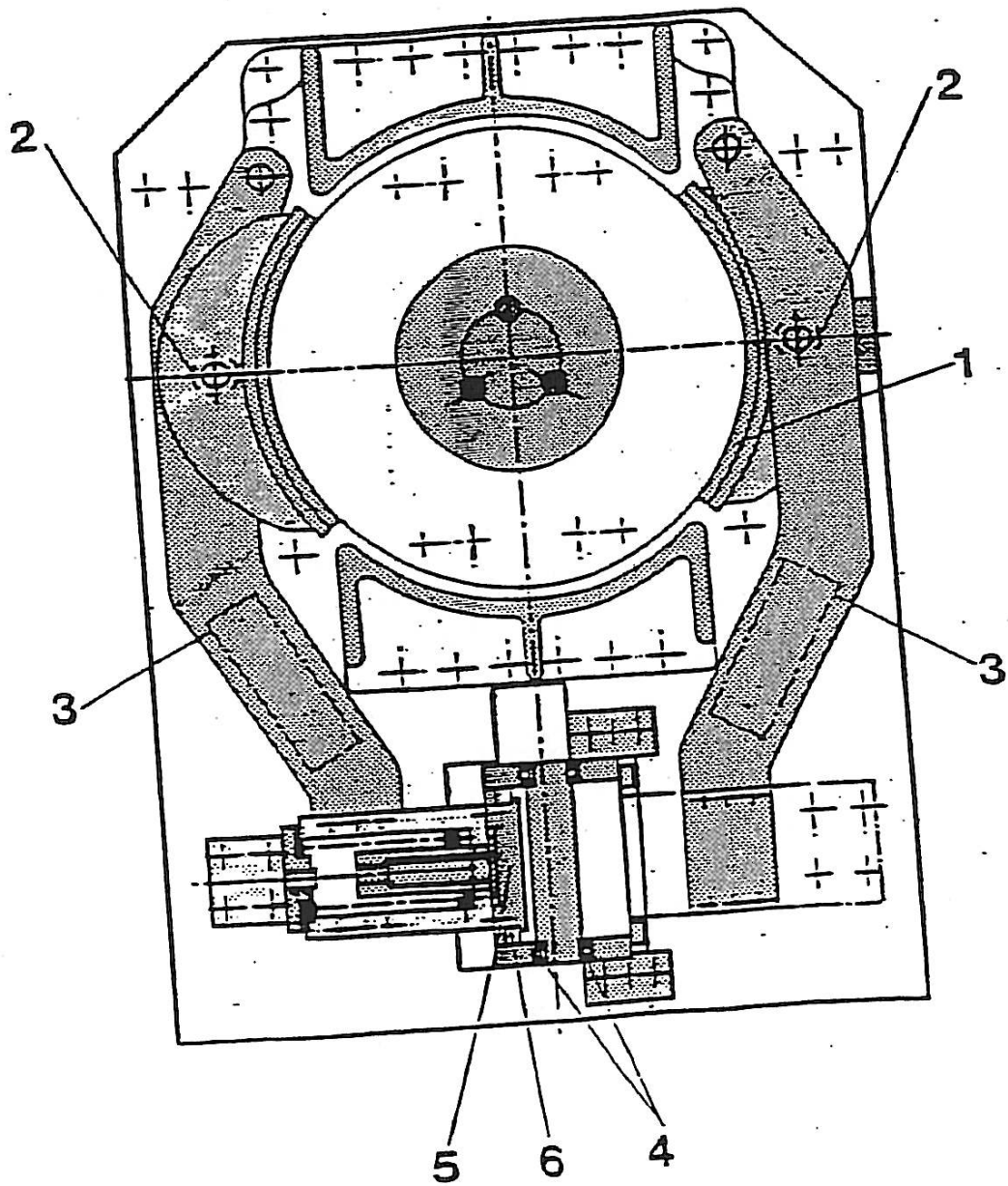

1. Brake lining
2. Brake shoe
3. Brake lever/calliper
4. Sliding gap / wear indication
5. Cylinder piston
6. Cylinder housing

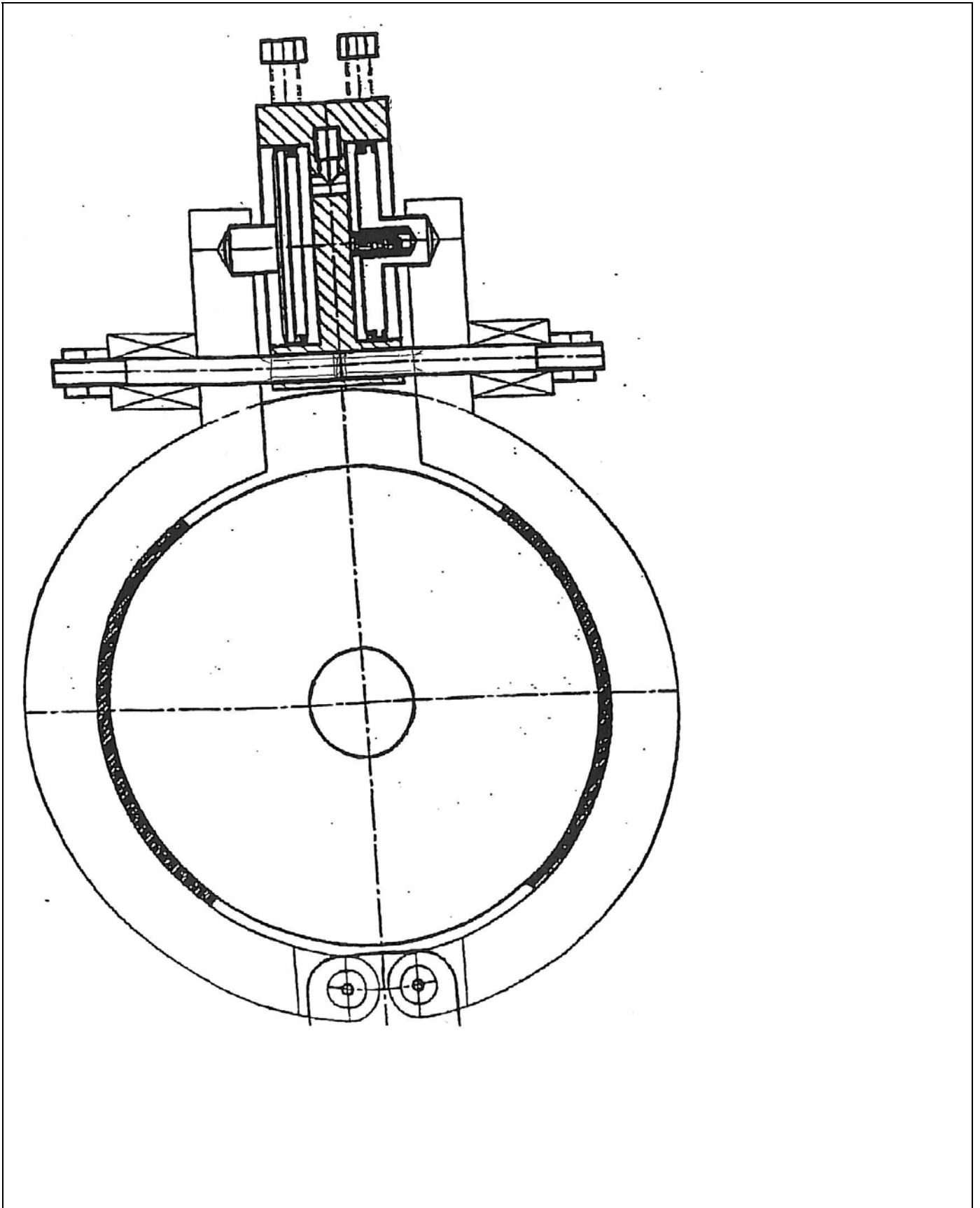

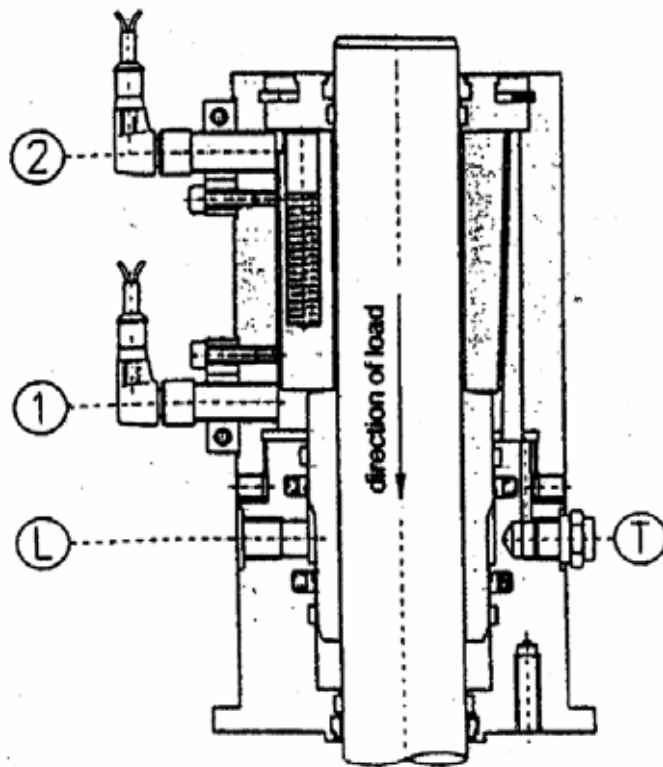



Figure of KR-Type

Legend

- | | | | |
|---------------------|---|---------------------------------------|-------------------|
| Sensors of position | { | 1 | Load secured |
| | | 2 | Clamping released |
| L inlet port | { | to introduce/ evacuate pressure | |
| T outlet port | | with the help of one auxiliary valve. | |

Figure 2

	CO-ORDINATION OF NOTIFIED BODIES MACHINERY DIRECTIVE 98/37/EC AMENDED RECOMMENDATION FOR USE		CNB/M/03.162 Revision 09 Language : E
Date of first stage : 09/10/2001	To be approved by :		Approved on :
Origin : VG3 Presses for the cold working of metals	<input checked="" type="checkbox"/> Vertical Group 20/03/2007 <input checked="" type="checkbox"/> Horizontal Committee		20/03/2007
	To be endorsed by : <input checked="" type="checkbox"/> Working Group 98/37/EC Machinery 21/04/2015		
Question related to : Dir. 98/37/EC Annex :	Article : EHSR (1) : 1.2.5, 1.4.3	prEN : 12622 : 2003 Normative clause : 5.2.5.5.3 CEN TC concerned : TC 143	Other : Other clause :
Key words : AOPD - Press Brakes			
Question : 1. Can an ESPE using AOPD in the form of laser beams for which the protective zone is close to the punch tip, fixed to the beam of a press brake be used as an alternative to the safeguarding measures described in 5.3.2 of EN 12622:2001? 2. What are the minimum requirements?			
Answer : See pages 2 and 3.			

(1) Essential health and safety requirement

Note : According to point 6.6 of the Guide of the implementation of directives based on the New Approach and the Global Approach, the notified bodies apply as general guidance this recommendation for use.

1. Yes, it can, for example, when the positioning of the protective zone is as described below:

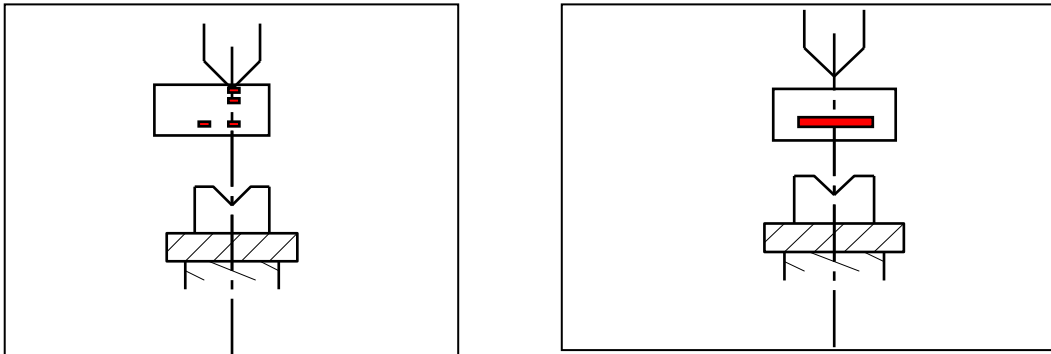

2. The minimum requirements are:
- 2.1 This is a safety component according to Annex IV of the Machinery Directive. It shall conform to type 4 in accordance with 4.2.2.5 of EN 61496-1:1997 (and be designed and constructed according to prEN 61496-2:1997 or equivalent). The intended use specific to press brakes must have been certified by a notified body.
- 2.2 The maximum stopping distance of the press brake shall not exceed the values given by the manufacturer of the protective device.
- 2.2 a It must be monitored at least for each first stroke after the press brake has been switched on. If this distance is exceeded, the press must be automatically stopped. This device must be at least category 3 of EN 954-1:1996 and monitored at least for each first stroke after the press brake has been switched on.
- 2.2 b During the construction of the press brake, the maximum stopping distance of the beam for each model and size of press brake has to be measured separately for each possible operating channel at least 10 times. The highest measured value or the mean plus 3 times the standard deviation shall be taken for the comparison. To measure this stopping distance, the conditions described in Annex A, paragraph A.4 of EN 12622:2001 shall be taken into account.
- 2.3 Access from the sides of the danger zone shall be prevented as described in clause 5.3.22 of EN 12622:2001.
- 2.4 Access from the rear of the danger zone shall be prevented as described in clause 5.3.23 of EN 12622:2001.
- 2.5 It must not be used for cycle initiation.
- 2.6 Muting
It shall be achieved at least as described in clause 5.3.15 of EN 12622:2001.
- 2.7 Blanking (Ref. prEN 12622 / CEN/TC143/WG1 Doc N 581)
For a special mode of operation, e.g. box bending, the following measures shall be taken to blank only the protection zone in front of the bending line with the protective field in the bending plane still active:
- Means of selection shall be provided for this special mode of operation,
 - A suitable indicator, active when the protection zone is blanked, shall be provided,
 - Blanking of this protection zone during the closing stroke is possible if the closing speed is reduced to 10 mm/s or less, in conjunction with a hold-to-run control device,
 - This special mode of operation shall be automatically de-activated
 - at each power on of the machine,
 - after a mode selection change,
 - after a change of program of the numerical control,

- within 8 hours running time,
- Blanking of this protection zone is also possible when the stroke is required in fast speed (more than 10 mm/s), given that the blanking function may be activated before each bending stroke by the control system (e.g. by information coming from the numerical control to determine the sequence of blanked and non blanked strokes). For each of the strokes requiring the blanking, the operator shall have a separate confirming action (e.g. push button or extra depression of foot pedal) before the blanking is permitted.

2.8 Positioning of the beams

- Clear indications must be included in the instruction handbook of the press brake, including the kind of tools which may be used (e.g. shape of the tools).
- Only the height of the beams may be adjusted by the user.

2.9 Additional guards preventing from the risks relating to the moving parts (between the safety device and the fixed parts of the press brake).

Adaptation of such a system must not create new hazards in relation to the fixed mechanical parts of the press brake.

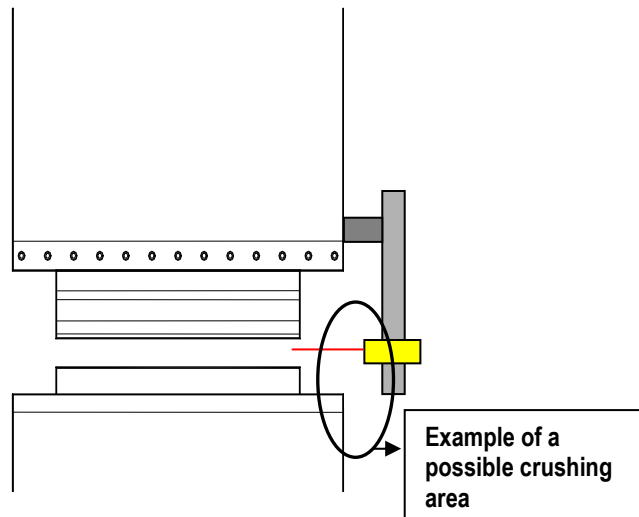

- 2.10 It shall be fixed to the press brake so that the changing of the tools (especially the punch) can be possible without removing the device from the press brake.
- 2.11 Hydraulic and electrical control systems shall be designed as described in clauses 5.2.3, 5.2.4 and 5.4 of EN 12622:2001.

	CO-ORDINATION OF NOTIFIED BODIES Machinery Directive 2006/42/EC + Amendment RECOMMENDATION FOR USE		CNB/M/03.165 Revision 05 Language: E
Date of first stage: 23/09/2002	To be approved by:		Approved on:
Origin: VG3 Presses for cold working metals	<input checked="" type="checkbox"/> Vertical Group	29/09/2009	
	<input checked="" type="checkbox"/> Horizontal Committee.....	16/06/2003	
	To be endorsed by:		Endorsed on:
	<input checked="" type="checkbox"/> Machinery Working Group.		17/12/2003
Question related to: Dir. 2006/42/EC	Article:	EN/prEN: prEN 12622:2009	Other:
Annex: I	EHSR (1): 1.3.7, 1.4.3	Normative clause: 5.1.1.4.1 f)	Other clause:
CEN TC concerned: TC 143			
Key words: Press Brakes, Light curtains-Blanking			
<p>Question:</p> <p>On press brakes fitted with light curtains it is often necessary to blank out partial areas (see figure 1) of the protection field only for making invisible the work-piece supports.</p> <p>Is it in this case obligatory to correct the safety distance between the protection field and the danger spot?</p>			
<p>Answer:</p> <p>It is not obligatory to correct the safety distance (see figure 2) when blanking if the following conditions are fulfilled:</p> <ul style="list-style-type: none"> - The resolution of the light curtain at the blanking point shall be ≤ 30 mm; means shall be provided to prevent the user from reprogramming the safety interface; - The resolution in the rest of the area shall be 14 mm; - The safety distance shall be calculated as described in Annex A of EN 12622:2001, using a resolution of 14 mm; - The safety distance shall be ≥ 150 mm; - It shall not be permitted to initiate cycles using the light curtain; - There shall not be more blanking areas than necessary for making invisible the sheet supports; - The manufacturer has to incorporate a warning into the operator's instruction manual to make him aware of the different resolutions in the two areas. <p>NOTE: When changing the height of the die, it is necessary to change the position of the blanking area to establish a clear correlation between the blanking area and the position of the sheet supports.</p> <p>Figures see page 2.</p>			
<p>Adaptation procedure: FORMAL ADAPTATION IN CONFORMITY WITH DIRECTIVE 2006/42/EC</p> <p>(1) Essential health and safety requirement</p> <p>Note: According to point 6.6 of the Guide of the implementation of directives based on the New Approach and the Global Approach, the notified bodies apply as general guidance this recommendation for use.</p>			

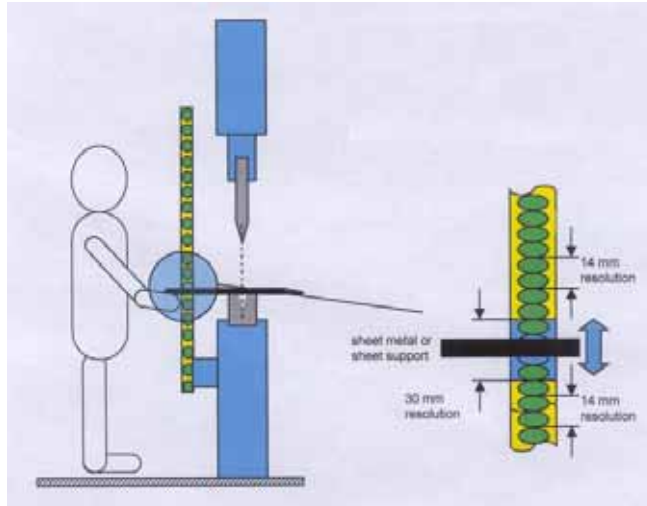

Figure 1

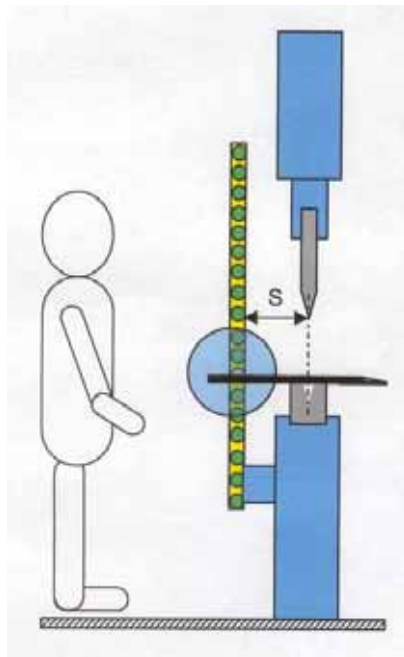



Figure 2

	CO-ORDINATION OF NOTIFIED BODIES Machinery Directive 2006/42/EC + Amendment RECOMMENDATION FOR USE	CNB/M/03.177 Revision 04 Language: E
Date of first stage: 07/06/2004	To be approved by:	Approved on:
Origin: VG3 Presses for cold working metals	<input checked="" type="checkbox"/> Vertical Group <input checked="" type="checkbox"/> Horizontal Committee..... To be endorsed by: <input checked="" type="checkbox"/> Machinery Working Group.	30/09/2009 09/12/2004 Endorsed on: 24/05/2005
Question related to: Dir. 2006/42/EC Article: Annex: I EHSR (1): 1.2.3	EN/prEN: prEN12622:2003/10 Normative clause: 5.2.5.5.3 n) CEN TC concerned: TC 143	Other: Other clause:
Key words: Hydraulic press brake - AOPD moving with the beam, box bending, mode confirmation		
<p>Question:</p> <p>5.2.5.5.3 Paragraph n) requires that any blanking shall require deliberate confirmation by the operator. Further, when this blanking is activated it shall need automatic deactivation after each cycle before or at next Top Dead Centre.</p> <p>Is it acceptable that this confirmation especially for box bend mode is derived from other means than the operator? Some machines do derive this confirmation from their CNC and therefore the confirmation is once programmed, from then on it is automatically. Is this an acceptable level of safety?</p> <p>Note:</p> <p>The question above is dealing with a programmable box bending sequence (predetermined number of strokes where some of these strokes, at least one, are carried out with a blanked front beam) in contradiction with paragraph e of 5.2.5.5.3 of prEN 12622:2003/10 where box bending mode is defined as a single stroke with blanked front beam.</p>		
<p>Solution:</p> <p>No, this is not acceptable. The new draft standard needs to clarify points e) and n) of clause 5.2.5.5.3. The aim of the requirement is to make the operator aware that the normal level of safety is only partially available.</p> <p>The box bending mode has to be selected by key selector switch or by appropriate positive means. After finishing a box bending sequence the system must return to normal mode of operation automatically. All strokes with blanked front beam at full speed need an additional or separate deliberate command (e.g. reapplication of foot pedal or push one additional button). In other case the beam works in slow speed.</p> <p>Hint:</p> <p>VG3 considers that there is a discrepancy between prEN12622:2003/10 and previous prEN12622:2001/10 (concerning paragraph b of 5.2.5.5.3 and the reference taken from paragraph d and e).</p> <p>Adaptation procedure: FORMAL ADAPTATION IN CONFORMITY WITH DIRECTIVE 2006/42/EC</p>		

(1) Essential health and safety requirement

Note: According to point 6.6 of the Guide of the implementation of directives based on the New Approach and the Global Approach, the notified bodies apply as general guidance this recommendation for use.

	<p style="text-align: center;">CO-ORDINATION OF NOTIFIED BODIES Machinery Directive 2006/42/EC + Amendment</p> <p style="text-align: center;">RECOMMENDATION FOR USE</p>	<p>CNB/M/03.179 Revision 04</p> <p>Language: E</p>
Date of first stage: 08/06/2004	To be approved by:	Approved on:
Origin: VG3 Presses for the cold working of metals	<input checked="" type="checkbox"/> Vertical Group <input checked="" type="checkbox"/> Horizontal Committee	29/09/2009 09/12/2004
	To be endorsed by: <input checked="" type="checkbox"/> Machinery Working Group....	Endorsed on: 24/05/2005
Question related to: Directive 2006/42/EC	Article:	EN/prEN: EN 12622:2001
Annex: I	ESR (1): 1.2.5	Other:
	Clause: 5.3.22, 7.2.2 u)	Other clause:
	GEN TC concerned: TC 143	
Key words: Press-brakes - Working with one side guard open		
Question:		
Which requirements shall be adopted to work with one or both of the interlocked side guards open?		
Solution:		
Either		
A) a key selector shall be installed that sets the slow closing speed (10 mm/s) and slow speed (2 m/min) of the back gauge over the full stroke or		
B) the opening of one or both side guards shall		
<input checked="" type="checkbox"/> always stop both the closing movement and slow speed movement, and make it necessary to release and reapply the control (foot pedal) to restart the closing movement, and		
<input checked="" type="checkbox"/> automatically set the slow closing speed (10 mm/s) and slow speed (2 m/min) of back gauge over the full stroke.		
The automatic opening of the press when at full speed should only be possible if no hazard is introduced by the opening stroke.		
If a lateral guard is closed during a slow speed closing operation, this movement may only continue at slow speed. To return to a high speed operation after closing the lateral guards, shall only be possible by reactivating the control (foot pedal). (see 5.4.1.1 b) EN 12622:2001)		
<p style="text-align: center;">Adaptation procedure: FORMAL ADAPTATION IN CONFORMITY WITH DIRECTIVE 2006/42/EC</p>		

(1) Essential safety requirement

Note: According to point 6.6 of the Guide of the implementation of directives based on the New Approach and the Global Approach, the notified bodies apply as general guidance this recommendation for use.

	CO-ORDINATION OF NOTIFIED BODIES Machinery Directive 2006/42/EC + Amendment RECOMMENDATION FOR USE	CNB/M/03.180 Revision 04 Language: E
Date of first stage: 08/06/2004	To be approved by:	Approved on:
Origin: VG3 Presses for cold working metals	<input checked="" type="checkbox"/> Vertical Group..... <input checked="" type="checkbox"/> Horizontal Committee To be endorsed by: <input checked="" type="checkbox"/> Machinery Working Group...	28/09/2009 09/12/2004 Endorsed on: 24/05/2005
Question related to: Dir. 2006/42/EC Article: Annex: I EHSR (1): 1.3.8	EN/prEN: EN 12622:2001 Normative clause: 5.3.24.1 CEN TC concerned: TC 143	Other: Other clause:
Key words: Press-brakes - Ancillary devices - Powered tools clamping devices		
Question: 1. In some cases press brakes are fitted with pneumatic or hydraulic tools clamping devices. Which requirements shall be adopted to prevent fingers being trapped during the locking movement? 2. What measures have to be taken to ensure a secure and correct locking of the tools?		
Solution: 1. To prevent the fingers being trapped during tool setting the manufacturer of the press-brakes shall give clear instructions in the machines manual about the residual risk concerning clamping devices. 2. It has to be ensured, that a loss of pressure does not lead to an insecure tool. This might be achieved by a system consisting of a mechanical tool retention or security system (both preventing the tool from falling down) together with either a) a mechanical forced clamping (e.g. by spring force) pneumatic or hydraulic energy only being used to de-clamp the tool* or b) a positive clamping by use of pneumatic or hydraulic energy together with a pressure sensing device interlocked with a control system of the press-brakes according to category 2 of EN954-1:1996. * Single faults in clamping device shall not lead to loss of the clamping function.		
Adaptation procedure: FORMAL ADAPTATION IN CONFORMITY WITH DIRECTIVE 2006/42/EC		

(1) Essential health and safety requirement

Note: According to point 6.6 of the Guide of the implementation of directives based on the New Approach and the Global Approach, the notified bodies apply as general guidance this recommendation for use.

	<p>CO-ORDINATION OF NOTIFIED BODIES</p> <p>Machinery Directive 2006/42/EC + Amendment</p> <p>RECOMMENDATION FOR USE</p>		<p>CNB/M/03.182</p> <p>Revision 04</p> <p>Language: E</p>
Date of first stage: 08/06/2004	To be approved by:		Approved on:
Origin: VG3 Presses for cold working metals	<input checked="" type="checkbox"/> Vertical Group <input checked="" type="checkbox"/> Horizontal Committee.....	<p>28/09/2009</p> <p>09/12/2004</p>	
<p>Question related to: Dir. 2006/42/EC Article:</p> <p>Annex: I EHSR (1): 1.3.7, 1.3.8</p>		<p>EN/prEN: prEN 12622:2008</p> <p>Normative clause: 5.1.1.5 n)</p> <p>CEN TC concerned: TC 143</p>	<p>Other:</p> <p>Other clause:</p>
Key words: Press-brakes - ESPE using AOPD in the form of laser beams - Additional crushing hazard			
<p>Question:</p> <p>How is it possible to avoid crushing between the safety device moving with the beam and any other part of the press-brakes?</p>			
<p>Answer:</p> <p>Doing the risk assessment about additional crushing hazards generated with these devices the normal consideration is to trap the hand.</p> <p>The following solutions solely or in combination may be helpful to ensure a sufficient level of safety.</p> <ol style="list-style-type: none"> 1. The AOPD moving with the beam has to be mounted in such a way, that it can be easily deflected by any part of the human body introduced beneath the moving part of the AOPD. 2. The distance between the edge of the safety device and the closest fixed parts of the press shall not be less than 100 mm (hands safety - EN 349:1993 + A1:2008). 3. The use of sensitive edges. <p>Adaptation procedure: FORMAL ADAPTATION IN CONFORMITY WITH DIRECTIVE 2006/42/EC</p>			

(1) Essential health and safety requirement

Note: According to point 6.6 of the Guide of the implementation of directives based on the New Approach and the Global Approach, the notified bodies apply as general guidance this recommendation for use.

	CO-ORDINATION OF NOTIFIED BODIES Machinery Directive 2006/42/EC + Amendment RECOMMENDATION FOR USE		CNB/M/03.185 Revision 05 Language: E
Date of first stage: 09/06/2004	To be approved by:		Approved on:
Origin: VG3 Presses for cold working metals	<input checked="" type="checkbox"/> Vertical Group <input checked="" type="checkbox"/> Horizontal Committee.....		30/09/2009 09/06/2005
Question related to: Dir. 2006/42/EC Article: Annex: I EHSR (1): 1.4.2; 1.4.2.2		To be endorsed by: <input checked="" type="checkbox"/> Machinery Working Group.	
Key words: Movable screens		EN/prEN: EN 693:2001, EN 692:2005+A1:2009 Normative clause: 5.3 CEN TC concerned: TC 143/WG1	
Question: Q: 1. Which safeguarding is necessary for pneumatically or electrically vertically driven guards on a press when the guard is manoeuvred with ordinary two hand control or when a single hold-to-run pushbutton is used? Q: 2. When is it acceptable to use an impulse button as the control device for movable guard? Q: 3. When must fall arresters (anti-drop safeguards) as described in EN 12604 be used?			
Solution: The manufacturer has to do a risk assessment according to EN 954-1:1996 to define the preferable category for the control system of the movement of the door. During this assessment the manufacturer will have to judge if the kinetic energy of the movement of the guard is big enough to cause serious injury. A:1. When a two hand control or a hold to run pushbutton is used for the guard and the operator has a good view of the area around the door and of the tool area no other safety measures have to be taken. The force (pressure) must be lower than 150 N (50 N/cm ²) or additional safeguarding measures have to be implemented in the trapping zone generated by the guards. A: 2. Always if the operator has a good view of the area around the door and of the tool area and it is not possible to enter the danger zone during the closing movement of the guard and if one of the following conditions is fulfilled: - the requirements of 5.2.5.2 of EN 953:2009 are fulfilled (e.g. a sensitive edge that reverses the door in case of obstruction is installed) or - there is no danger presented by the guard. A: 3. If one single mechanical fault leads to an unintended gravity fall causing a force exceeding 150 N additional safe guarding measures shall be taken into consideration (e.g. fall arresters, double independent drive systems, over dimensioning of critical parts or other solutions as described in EN 12604). Adaptation procedure: FORMAL ADAPTATION IN CONFORMITY WITH DIRECTIVE 2006/42/EC			

(1) Essential health and safety requirement

Note: According to point 6.6 of the Guide of the implementation of directives based on the New Approach and the Global Approach, the notified bodies apply as general guidance this recommendation for use.

	CO-ORDINATION OF NOTIFIED BODIES Machinery Directive 2006/42/EC + Amendment RECOMMENDATION FOR USE		CNB/M/03.186 Revision 06 Language: E	
Date of first stage: 09/06/2004	To be approved by:		Approved on:	
Origin: VG3 Presses for cold working metals	<input checked="" type="checkbox"/> Vertical Group	28/09/2009	<input checked="" type="checkbox"/> Horizontal Committee.....	26/11/2009
Question related to: Dir. 2006/42/EC Article: Annex: IV-9 EHSR (1):	EN/prEN: EN692:2005+A1:2009(1), EN 693:2001+A1:2009(2), EN 12622:2001(3), Normative clause: 5.4.4 (1), 5.4.3 (2), 5.4.2 (3), CEN TC concerned: TC 143		Other: Other clause:	
Key words: Acceptability of a component, configurable or parameterizable PES				
Question: Should a manufacturer of a press, that relies on the below described PES to manage the safety control functions of the machine have carried out an EC type examination or produce the machine using a full quality assurance system approved by a notified body according to annex X of the Machinery Directive 2006/42/EC or not ?				
Description: According to above mentioned clauses the safety related functions of presses shall not rely solely on a PES. Recently several safety programmable electronic systems (SPES) have appeared on the market referred as configurable safety relay, or parameterizable safety unit, etc. These systems differ from the freely-programmable safety control systems in the following features: The function blocks are already programmed and certified. Programming an application consist of doing the following steps, in a graphical user-interface: a) Choosing the input functions (icon boxes), unfolding input function windows for setting their specific parameters and assigning connection terminals to the input functions b) Doing the same for the output functions c) Calling the linking functions (AND, OR, etc.) and d) Wiring all blocks; The user does not need to develop a complex programme properly, but these systems are also considered to be PES. Some systems are dedicated to an application and the main part of the logic is already programmed, so the manufacturers of the machines only have to properly parameterize (tailor) the system to its own application. Solution: Yes, Manufacturers of annex IV machinery are obligated to follow EC type examination procedure or manufacture using a full quality assurance system as described above as long as these types of safety systems are excluded from above mentioned harmonised standards.				

(1) Essential health and safety requirement

Note: According to point 6.6 of the Guide of the implementation of directives based on the New Approach and the Global Approach, the notified bodies apply as general guidance this recommendation for use.

	<p>CO-ORDINATION OF NOTIFIED BODIES Machinery Directive 2006/42/EC + Amendment</p> <p>RECOMMENDATION FOR USE</p>	<p>CNB/M/03.187 Revision 05 Language: E</p>
<p>Date of first stage: 09/06/2004</p> <hr/> <p>Origin: VG3 Presses for cold working metals</p>	<p>To be approved by:</p> <p><input checked="" type="checkbox"/> Vertical Group</p> <p><input checked="" type="checkbox"/> Horizontal Committee.....</p> <p>To be endorsed by:</p> <p><input checked="" type="checkbox"/> Machinery Working Group.</p>	<p>Approved on:</p> <p>30/09/2009</p> <p>09/06/2005</p> <p>Endorsed on:</p> <p>29/10/2005</p>
<p>Question related to: Dir. 2006/42/EC Article:</p> <p>Annex: I EHSR (1): 1.2; 1.3.2</p>	<p>EN/prEN: EN 692:2005+A1:2009 Other:</p> <p>Normative clauses: 5.2.6, 5.2.6.4 Other clause:</p> <p>CEN TC concerned: TC 143</p>	
<p>Key words: failure of auxiliary powered functions for setting</p>		
<p>Question:</p> <p>Automatic systems to facilitate the tool setting of presses, such as powered drives for slide and stroke adjustment and for their locking (e.g. clamping devices of the eccentric and the screw) are available on the market. It is intended that they are manually initiated via a deliberate/intended action.</p> <p>EN 692 clause 5.2.6 specifies requirements for interlocks between control circuits of drives and clutches and also to ensure the locking of adjustments during production (5.2.6.4).</p> <p>Therefore:</p> <p>a) Which categories shall control circuits for powered slide adjustment (e.g. control of position of the eccentric and other associated bars) conform to in the case of manual loaded and/or unloaded mechanical presses?</p> <p>b) Which categories shall control circuits for the stroke adjustment (e.g. control of the correct clamping of the screw) conform to</p> <ul style="list-style-type: none"> • in the case of manual loaded and/or unloaded mechanical presses? 		
<p>Answer:</p> <p>Firstly, these functions shall only be available in setting mode:</p> <p>a) The control circuits for locking powered slide adjustment in the correct position for production mode shall at least conform to Category 1. Additionally the position of the clamping devices shall be monitored. This function must be automatically tested at least at each of tool setting.</p> <p>b) The control circuits for locking the powered stroke adjustment in the correct position for production mode shall at least conform to Category 1.</p>		
<p>Adaptation procedure: FORMAL ADAPTATION IN CONFORMITY WITH DIRECTIVE 2006/42/EC</p>		

(1) Essential health and safety requirement
Note: According to point 6.6 of the Guide of the implementation of directives based on the New Approach and the Global Approach, the notified bodies apply as general guidance this recommendation for use.

 <p>EUROPEAN CO-ORDINATION MACHINERY OF NOTIFIED BODIES</p>	<p>CO-ORDINATION OF NOTIFIED BODIES Machinery Directive 2006/42/EC + Amendment</p> <p>RECOMMENDATION FOR USE</p>	<p>CNB/M/03.188 Revision 06 Language: E</p>
<p>Date of first stage: 07/06/2004</p> <p>Origin: VG3 Presses for cold working metals</p>	<p>To be approved by:</p> <p><input checked="" type="checkbox"/> Vertical Group.....</p> <p><input checked="" type="checkbox"/> Horizontal Committee</p> <p>To be endorsed by:</p> <p><input checked="" type="checkbox"/> Machinery Working Group...</p>	<p>Approved on:</p> <p>28/09/2009</p> <p>10/08/2008</p> <p>Endorsed on:</p> <p>08/01/2009</p>
<p>Question related to: Dir. 2006/42/EC Article:</p> <p>Annex: I EHSR (1): 1.4.2.2</p>	<p>EN/prEN: EN 692: 2005, EN 693 :2001</p> <p>Normative clause:</p> <p>CEN TC concerned: TC 143</p>	<p>Other: EN 13736:2003</p> <p>Other clause:</p>
<p>Key words: Front guard switch</p>		
<p>Question:</p> <p>Is only one non mechanical actuated switching unit consisting of one active and one inactive part (e.g. a magnetic switch) acceptable for interlocking a cyclic front guard of a press?</p>		
<p>Solution :</p> <p>Yes, if:</p> <ul style="list-style-type: none"> - The switching unit and the safety logic fulfil category 4 of EN 954-1 (redundant and monitored) and - A cyclic test (at least once per stroke) is done in any operational mode to verify that the moving part of the switching unit is not attached to the other part permanently. A negative test result shall lead to a prevention of further stroke initiation. The cyclic test can be done e.g. by a standard PLC. <p>If a cyclic test can not be done (e.g. when the press can be operated also in automatic mode) the switching unit shall be mounted so that the actuating part of the unit can not be removed for the purpose of disabling the safety system (see EN 1088:1995/prA1:2005). The parts of the switching unit must then be a "unique" pair.</p> <p>"Unique" means that it is unlikely to find another matching part that can be used to defeat the protective system.</p> <p>Adaptation procedure: FORMAL ADAPTATION IN CONFORMITY WITH DIRECTIVE 2006/42/EC</p>		

(1) Essential health and safety requirement

Note: According to point 6.6 of the Guide of the implementation of directives based on the New Approach and the Global Approach, the notified bodies apply as general guidance this recommendation for use.

	CO-ORDINATION OF NOTIFIED BODIES Machinery Directive 2006/42/EC + Amendment RECOMMENDATION FOR USE	CNB/M/03.189 Revision 05 Language: E
Date of first stage: 31/08/2005	To be approved by:	
Origin: VG3 Presses for cold working metals	<input checked="" type="checkbox"/> Vertical Group..... <input checked="" type="checkbox"/> Horizontal Committee	Approved on: 30/09/2009 21/11/2005
		To be endorsed by: <input checked="" type="checkbox"/> Machinery Working Group.
Question related to: Dir. 2006/42/EC	Article:	EN/prEN: EN 1088:1995 +A2:2008 Other:
Annex: I	EHSR (1): 1.4.1	Normative clause: Other clause:
		CEN TC concerned:
Key words: Defeat of protective measures on presses		
Question: Which methods may be used to prevent unauthorized loosening or tampering of screws/settings when the risk of manipulation is high and the manipulation will not be detected by the control system for: <ul style="list-style-type: none"> • Interlock switches and their keys • Non-mechanical interlock switches (e.g. magnetic, proximity switches) • Press table extensions used to prevent standing behind the light curtain considering that these extensions sometimes are damaged and therefore it must be possible to change/repair them Adjustable hydraulic valves/safety valves		
Solution: Answer : Possible methods are those ones where the destruction of the fastener is necessary for disassembling, e.g.: <ul style="list-style-type: none"> • One way screws • Screws with destroyed head e.g. drilled out or epoxy filled allen/torx/Phillips/pozidrive screw • Spot welded screws • Spot welding on the part itself • Riveting • Sealing with lead or similar methods is only acceptable to prevent from unauthorized manipulation of valves <p>The use of "safety screws" which can be loosened with a special tool without destroying them is not considered to be sufficient for fixing a single interlocking switch.</p> See EN 1088:1995/prA1:2004 (ISO/TC 199 WG 7 N0006) <p>Adaptation procedure: FORMAL ADAPTATION IN CONFORMITY WITH DIRECTIVE 2006/42/EC</p>		

(1) Essential Health and Safety Requirement

Note: According to point 6.6 of the Guide of the implementation of directives based on the New Approach and the Global Approach, the notified bodies apply as general guidance this recommendation for use.

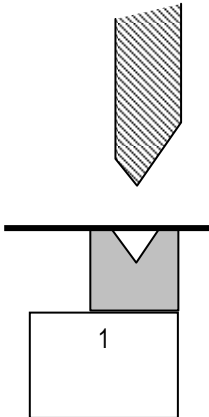
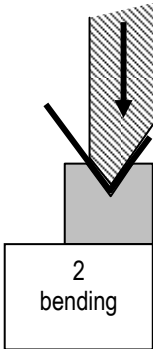
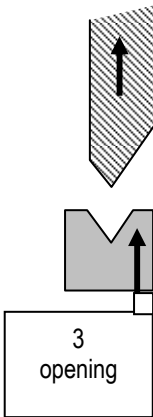
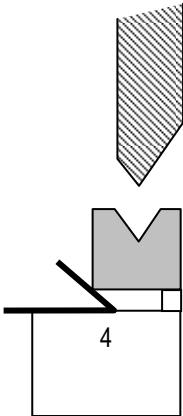
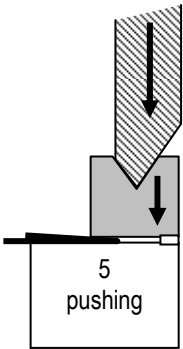
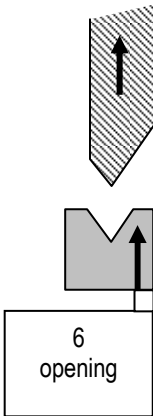
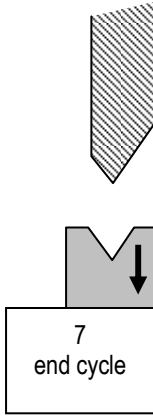
	<p>CO-ORDINATION OF NOTIFIED BODIES Machinery Directive 2006/42/EC + Amendment</p> <p>RECOMMENDATION FOR USE</p>	<p>CNB/M/03.192 Revision 04 Language: EN</p>
<p>Date of first stage: 21/03/2006</p>	<p>To be approved by:</p>	<p>Approved on:</p>
<p>Origin: VG3 Presses for cold working metals</p>	<p><input checked="" type="checkbox"/> Vertical Group..... <input checked="" type="checkbox"/> Horizontal Committee</p> <p>To be endorsed by: <input checked="" type="checkbox"/> Machinery Working Group.</p>	<p>06/10/2008 09/12/2008</p> <p>Endorsed on: 18/06/2009</p>
<p>Question related to: Dir. 2006/42/EC Article: Annex: 1 EHSR (1):</p>	<p>EN/prEN: EN 12622:2001 Normative clause: CEN TC concerned: TC 143</p>	<p>Other: pr EN 12622:2007 Other clause :</p>
<p>Key words: Press brakes – secondary working devices</p>		
<p>Question:</p> <p>Some press bakes are equipped with secondary devices (e.g. bend and push devices) which don't stand in he bending zone but can use the down stroke movement to perform the operation. This equipment is usually pneumatic with at least two single effect cylinders.</p> <p>What should the safety devices of this secondary working part be?</p> <div style="display: flex; flex-wrap: wrap; justify-content: space-around;"> <div style="text-align: center; margin: 10px;">  <p>1</p> </div> <div style="text-align: center; margin: 10px;">  <p>2 bending</p> </div> <div style="text-align: center; margin: 10px;">  <p>3 opening</p> </div> <div style="text-align: center; margin: 10px;">  <p>4</p> </div> <div style="text-align: center; margin: 10px;">  <p>5 pushing</p> </div> <div style="text-align: center; margin: 10px;">  <p>6 opening</p> </div> <div style="text-align: center; margin: 10px;">  <p>7 end cycle</p> </div> </div>		

Solution:

This type of tool has two danger zones. The first danger zone (a) is between the main tool and secondary tool and the second danger zone (b) is underneath the secondary tool.

- (a) The closing movement of the main tool should be protected with suitable safeguards.
The relationship of the movements between the main and the secondary tool need to be protected to prevent crushing between the main and the secondary tool in normal operation and due to unintended opening of the secondary tool
- (b) If the gap within the secondary tool is less or equal to 6mm the closing movement is not considered to be dangerous.
If the gap within the secondary tool is greater than 6mm a crushing hazard exists therefore the closing movement should be protected with suitable safeguards.

Suitable safeguards to address (a) and (b) above could be:

- Light curtains of type 4 according to EN 61496-1 which stop the closing movement of the beam and any movement of the secondary tool as soon they are interrupted in combination with monitoring and inbuilt redundancy of the drive of the secondary tool (see also EN 13736 pneumatic presses).

or

- A hold-to-run control device in conjunction with a maximum speed of 10mm/s (safe or monitored by a system of cat. 3 acc EN 954-1 or PL_D acc. to EN 13849-1) of the secondary tool for the initiation of the closing and opening movement of the secondary tool when used in combination with interlocking which prohibits any upward movement of the secondary tool as long as the main tool is in down stroke mode.

or

- A hold-to-run control device in conjunction with a maximum speed of 10mm/s (safe or monitored by a system of cat. 3 acc. to EN 954-1 or PL_D acc. to EN 13849-1) of the secondary tool for the initiation of the closing movement of the secondary tool when used in combination with
 - synchronisation (of cat. 3 acc. to EN 954-1 or PL_D acc. to EN 13849-1) between the upward movement of the main and the secondary tool in a manner that ensures that the speed of the main tool is always higher than the speed of the secondary tool so that the gap between the tools is always increasing during this movement

or

- a system of category 3 according to EN 954-1 or PL_D according to EN 13849-1 preventing the opening of the secondary tool as long as the beam has not reached a minimum distance from the secondary tool of 100 mm plus the stroke of the secondary tool.

Adaptation procedure: FORMAL ADAPTATION IN CONFORMITY WITH DIRECTIVE 2006/42/EC

(1) Essential health and safety requirement

Note: According to point 6.6 of the Guide of the implementation of directives based on the New Approach and the Global Approach, the notified bodies apply as general guidance this recommendation for use.

	CO-ORDINATION OF NOTIFIED BODIES Machinery Directive 2006/42/EC as amended RECOMMENDATION FOR USE		CNB/M/03.193 Revision : 06 Language : EN
Number of pages : 1	Date : 20.03.2006	To be approved by :	
Origin : VG3 Presses for the cold working of metals		<input checked="" type="checkbox"/> Vertical Group <input checked="" type="checkbox"/> Horizontal Committee	Approved on : 03.03.2009 10.06.2009
Question related to : Dir. 2006/42/EC Article : - Annex : I EHSR (1) : 1.2.1		EN/prEN : no applicable standard Normative clause : - CEN TC concerned : -	Other : EN 692:2005, EN 693:2001, EN 12622:2001 Other clause : -
Key words: Servo Press (Power Presses & Press Brakes), Muting, Slow Speed / Directional Monitoring			
Question: How is it possible to mute the safeguarding devices of a servo press where the stopping time is relevant?			
Recommended solution: a) Mute during opening movement The muting of the safeguarding device during opening movement shall be in accordance with EN ISO 13849-1:2008 category 4 PL e. The direction monitoring shall be in accordance with EN ISO 13849-1:2008 PL d. In case of failure, the maximum movement of the beam in the closing direction shall be limited to a reasonable value (good experiences have been made with a value not exceeding 6 mm). b) Mute during slow speed in conjunction with hold to run control Slow closing speed less than or equal to 10 mm/s that allows the muting of the safeguarding device shall be: - limited by fixed means (e.g. use of a clutch), or - monitored according to EN ISO 13849-1:2008 PL d. The over-speed detection shall have an adequately short response time. In case of over-speed detection a STO shall be applied and the braking mechanism shall be activated. The release of the hold to run control (e.g. foot pedal) shall lead to a Safe Stop 1.			

Note : According to point 6.6 of the Guide of the implementation of directives based on the New Approach and the Global Approach, the notified bodies apply as general guidance this recommendation for use.

Sent for information to: members of the VG other(s) VG HC (2) TC (3) SC (4) other (5)

(1) Essential Health and Safety Requirement
(2) Horizontal Committee

(3) N° of CEN/TC (Secretary & Chairman)
(4) Machinery Working Group

(5) To be specified

	CO-ORDINATION OF NOTIFIED BODIES Machinery Directive 2006/42/EC + Amendment RECOMMENDATION FOR USE	CNB/M/03.194 Revision 05 Language: E
Date of first stage: 03/03/2008	To be approved by:	Approved on:
Origin: VG3 Presses for cold working of metals	<input checked="" type="checkbox"/> Vertical Group	03/03/2009
	<input checked="" type="checkbox"/> Horizontal Committee	10/06/2009
Question related to: Directive 2006/42/EC Article: Annex: I ESR (1): 1.2.6	EN/prEN: EN 692:2005, EN 693:2001, EN 12622:2001	Other:
	Clause:	Other clause:
	CEN TC concerned:	
Key words: Servo press (Power Presses & Press Brakes), brake		
Question: What kind of brake system could be used on a mechanical press without a clutch, driven by a servo-drive system?		
Solution: If the servo controller provides a safe torque off function (STO) according to ISO 13849-1:2006 category 4 PL e, a stop category 1 acc. to EN 60204-1:2007 and a stopping performance monitoring according to ISO 13849-1:2006 PL d the following solutions may be acceptable: External mechanical brakes shall be used. They shall be mechanically and positively linked to the ram. If no mechanical and positive link is realised equivalent measures shall be taken. Circuits driving the brake systems shall be designed and monitored according to the needs of the safety control system. a) If the stopping time is relevant (depending on the safeguarding system e.g. non physical barrier) fail safe brake systems (e.g. a single brake as specified in EN 692 or equivalent) shall be used and a test of the brake performance has to be done to show the sufficient friction of the brake. If this test is done in a stand still position, it must be shown that also the stopping time under worst case conditions will be guaranteed. The interpretation of the test result must be done by the safety control system. The test has to be done at each power on, at each change of operational mode and at least after one hour of operation in single stroke mode or after eight hours of operation in automatic mode. The relevant sections of Annex B.4 of EN 692:2005 shall be taken into consideration for the design and testing of the brake. b) If the stopping time is not relevant a spring operated park brake system alone may be enough. In any case the stand still of the ram shall be monitored. The braking torque of external mechanical brakes preventing descent of the load (normally the ram) shall be reasonably overdimensioned (recommended value 1,25) with respect to the total mass of the ram including fitted tooling. Note: STO is defined in IEC 61800-5-2:2007		

(1) Essential safety requirement

Note: According to point 6.6 of the Guide of the implementation of directives based on the New Approach and the Global Approach, the notified bodies apply as general guidance this recommendation for use.

	CO-ORDINATION OF NOTIFIED BODIES Machinery Directive 2006/42/EC + Amendment RECOMMENDATION FOR USE	CNB/M/03.200 Revision 05 Language: E
Date of first stage: 25/09/2008	To be approved by:	Approved on:
Origin: VG3 Presses for the cold working of metals	<input checked="" type="checkbox"/> Vertical Group	03/03/2009
	<input checked="" type="checkbox"/> Horizontal Committee	10/06/2009
Question related to: Directive 2006/42/EC Article: Annex: I ESR (1): 1.2.4	EN/prEN: EN 692:2005, EN 693:2001, EN 12622:2001	Other:
	CEN TC concerned:	
Key words: Servo-presses (Power Presses & Press Brakes), Stopping performance monitoring		
Question: Stopping performance monitoring on servo - presses Which solution is acceptable?		
Solution: Where the response time (stopping performance) of a servo-press is safety-relevant, the response time has to be determined taking into account all errors concerning safety. If it is not possible for the press's safety control system to detect certain faults at least at the following check, the (additional) occurrence of further faults must be assumed. The effect of any assumable fault on the response time of the stopping function has to be taken into account for the calculation of the safety distance.		

(1) Essential safety requirement

Note: According to point 6.6 of the Guide of the implementation of directives based on the New Approach and the Global Approach, the notified bodies apply as general guidance this recommendation for use.

	CO-ORDINATION OF NOTIFIED BODIES Machinery Directive 2006/42/EC + Amendment RECOMMENDATION FOR USE		CNB/M/03.201 Revision 05 Language: E	
Date of first stage: 25/09/2008	To be approved by:		Approved on:	
Origin: VG3 Presses for the cold working of metals	<input checked="" type="checkbox"/> Vertical Group		04/03/2009	
	<input checked="" type="checkbox"/> Horizontal Committee		10/06/2009	
		To be endorsed by:		Endorsed on:
		<input checked="" type="checkbox"/> Machinery Working Group....		25/12/2009
Question related to: Directive 2006/42/EC Annex: I	Article: ESR (1): 1.2.1, 1.2.3	EN/prEN: EN 692:2005, EN 693:2001, EN 12622:2001 Clause: CEN TC concerned:	Other: Other clause:	
Key words: Servo-presses (Power Presses & Press Brakes), STO, prevention of unintended start				
Question: Which category / performance level is necessary for the safe torque off (STO) function of each drive of a press slide driven by more than one servo drive?				
Solution: The current power press standards as well as the press brake standard require category 4 of EN 954-1:1996 for the overall stopping performance of the slide. This general requirement is also valid for servo presses. With respect to the new standard EN ISO 13849-1:2008 the corresponding requirement is PL e and category 4. Where the unexpected start of one of the drives cannot lead to significant slide movement (e.g. not more than 6 mm) because the slide is blocked due to the mechanical construction of the press the category and performance level of the STO of each drive may be of the next lower level compared to the level required for a press with a single servo drive as long as the performance level stays equal to or above d.				

(1) Essential safety requirement

Note: According to point 6.6 of the Guide of the implementation of directives based on the New Approach and the Global Approach, the notified bodies apply as general guidance this recommendation for use.

	CO-ORDINATION OF NOTIFIED BODIES Machinery Directive 2006/42/EC + Amendment RECOMMENDATION FOR USE	CNB/M/03.202 Revision 04 Language: E
Date of first stage: 03/03/2009	To be approved by:	Approved on:
Origin: VG3 Presses for the cold working of metals	<input checked="" type="checkbox"/> Vertical Group <input checked="" type="checkbox"/> Horizontal Committee To be endorsed by: <input checked="" type="checkbox"/> Machinery Working Group....	03/03/2009 10/06/2009 Endorsed on: 25/12/2009
Question related to: Directive 2006/42/EC Article: Annex: I ESR (1): 1.3.7	EN/prEN: EN 12622:2009 Clause: 5.3.21 CEN TC concerned: TC 143	Other: Other clause:
Key words: Press brakes – back gauge movement initiation		
Question: Which alternative protective measures besides those described in clause 5.3.21 of EN 12622:2009 are acceptable to protect operators against hazardous movements of back gauges?		
Solution: It is also acceptable to protect the operator against the hazards arising from the movement of automatically operated back gauges by light curtains (e.g. the light curtain which also protects against access to the press from the front). If none of the features “movement initiation by the operator” or “demarcation of a zone with reduced speed / limited force” or “protection by light curtain” is active for protection against movement of the back gauges, no movement of the back gauges shall be possible.		

(1) Essential safety requirement

Note: According to point 6.6 of the Guide of the implementation of directives based on the New Approach and the Global Approach, the notified bodies apply as general guidance this recommendation for use.

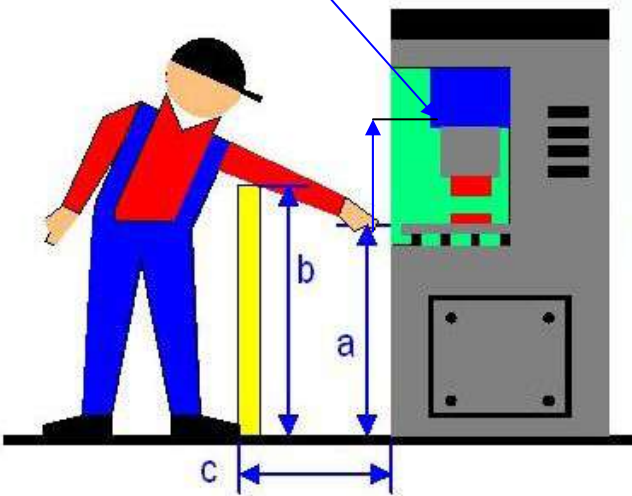
	CO-ORDINATION OF NOTIFIED BODIES Machinery Directive 2006/42/EC + Amendment RECOMMENDATION FOR USE	CNB/M/03.204 Revision 03 Language: E
Date of first stage: 28/09/2011	To be approved by:	Approved on:
Origin: VG3 Presses for cold working metals	<input checked="" type="checkbox"/> Vertical Group <input checked="" type="checkbox"/> Horizontal Committee To be endorsed by: <input checked="" type="checkbox"/> Machinery Working Group....	28/09/2011 11/12/2012 Endorsed on: 04/06/2013
Question related to: Directive 2006/42/EC Article: Annex: ESR (1): 1.4.2., 1.4.3.	EN/prEN: EN 692 :2005+A1:2009, EN 693 :2001+A2:2011 Clause: 5.3.2 CEN TC concerned: TC 143 and ISO TC 39/SC 10	Other: EN ISO 13857:2008, 13855:2010 Other clause:
Key words: Presses – Safety distances		
<p>Question:</p> <p>Where a movable or a fixed guard is used to prevent the access to the tools area of presses the Table 1 or 2 of EN ISO 13857:2008 standard shall be checked to verify that it is impossible reaching over the protective structure. In the same way if a light curtain is installed the EN ISO 13855:2010 table 1 shall be verified.</p> <p>To do this it is necessary to fix the height of the hazard zone that is the closing area between the fixed half tool and the movable half tool.</p> <p>How it is possible to identify this hazard zone when the height of the two separate mould halves is unknown?</p>		
<p>Solution:</p> <p>In principle it is impossible to define a minimum or a maximum height of the tools.</p> <p>The dimension of the hazard zone is basically defined by value "a" as determined during the examination considering any possible situation from the maximum opening of the ram to the height of the table.</p> <p>"c" and "b" must be determined according to EN ISO 13857 and EN ISO 13855 considering:</p> <ul style="list-style-type: none"> - the stopping time and - either the maximum size of the table/ram or the maximum size of the tool whichever is larger. <p>Maximum ram opening position</p>  <p>"a", "b" and "c" are those defined in the corresponding standard (EN ISO 13857 or EN ISO 13855) depending of the safety device</p>		





(1) Essential safety requirement

Note: According to point 6.6 of the Guide of the implementation of directives based on the New Approach and the Global Approach, the notified bodies apply as general guidance this recommendation for use.

	CO-ORDINATION OF NOTIFIED BODIES Machinery Directive 2006/42/EC + Amendment RECOMMENDATION FOR USE	CNB/M/03.206 Revision 03 Language: E
Date of first stage: 27/09/2012	To be approved by:	Approved on:
Origin: VG3 Presses for cold working metals	<input checked="" type="checkbox"/> Vertical Group	27/09/2012
	<input checked="" type="checkbox"/> Horizontal Committee	11/12/2012
Question related to: Directive 2006/42/EC Article: Annex: I ESR (1): 1.4.3.	To be endorsed by:	Endorsed on:
	<input checked="" type="checkbox"/> Machinery Working Group....	04/06/2013
EN/prEN: EN 692 :2005+A1:2009	Other: EN 693: 2001+A2:2011	
Clause: 5.3.2.	Other clause:5.3.16	
CEN TC concerned: TC 143		
Key words: Presses – Two hand control device (THCD)		
Question:		
Can the THCD be used as the solely protection device for a press at the operator side?		
Solution:		
According to EN 692:2005+A1:2009 clause 5.3.2. the manufacturer shall select the safeguard method which reduces the risks as far as possible, considering the significant hazards and the method of protection.		
The operator(s) must have the possibility to overview all the dangerous area at any time (considering the presence of tools and material).		
It is recommended that if the horizontal access is more than 650 mm [ref EN 693:2001+A2:2011 clause 5.3.16] other safeguarding devices than THCD according to the risk assessment for the particular press should be provided to protect a third person.		



(1) Essential safety requirement

Note: According to point 6.6 of the Guide of the implementation of directives based on the New Approach and the Global Approach, the notified bodies apply as general guidance this recommendation for use.

	<p>CO-ORDINATION OF NOTIFIED BODIES Machinery Directive 2006/42/EC + Amendment</p> <p>RECOMMENDATION FOR USE</p>	<p>CNB/M/03.207 Revision 03</p> <p>Language: E</p>
Date of first stage: 27/09/2012	To be approved by:	
Origin: VG3 Presses for cold working metals	<input checked="" type="checkbox"/> Vertical Group <input checked="" type="checkbox"/> Horizontal Committee	Approved on: 27/09/2012 11/12/2012
	To be endorsed by: <input checked="" type="checkbox"/> Machinery Working Group....	Endorsed on: 04/06/2013
Question related to: Directive 2006/42/EC Article: Annex: I ESR (1): 1.3.7.	EN/prEN: EN 12622: 2009 Clause: 5.2.5.6. CEN TC concerned: TC 143	Other: EN 13849-1:2008 Other clause:
Key words: Press-brakes – Powered work-piece supports		
Question: EN 12622: 2009 clause 5.2.5.6 c) requires that the unexpected start-up for powered work-piece supports shall be prevented when a hold-to-run control is used. How can be implemented in the control circuit?		
Solution: The control circuit of the hold-to-run control shall conform at least PLr=b EN 13849-1:2008. Explanation: according to EN 13849-1:2008: <ul style="list-style-type: none">  S=1 due to reversible injury,  F=2 due to permanent work place,  P=1 due to sufficient space around and below the work-piece support. 		

(1) Essential safety requirement

Note: According to point 6.6 of the Guide of the implementation of directives based on the New Approach and the Global Approach, the notified bodies apply as general guidance this recommendation for use.

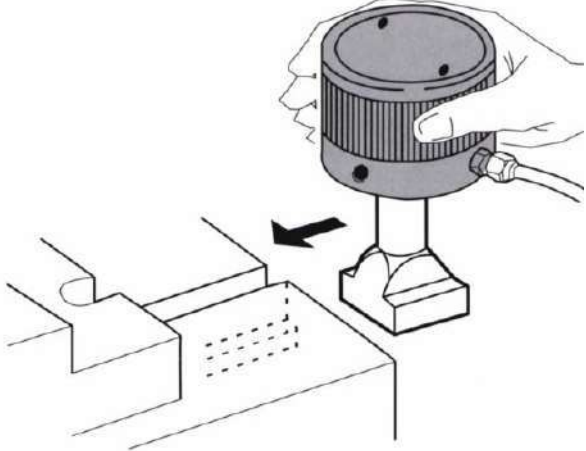
	CO-ORDINATION OF NOTIFIED BODIES Machinery Directive 2006/42/EC + Amendment RECOMMENDATION FOR USE	CNB/M/03.209 Revision 03 Language: E
Date of first stage: 26/09/2013 Origin: VG3 Presses for cold working metals		To be approved by: <ul style="list-style-type: none"> <input checked="" type="checkbox"/> Vertical Group <input checked="" type="checkbox"/> Horizontal Committee Approved on: <ul style="list-style-type: none"> 26/09/2013 10/12/2013 To be endorsed by: <ul style="list-style-type: none"> <input checked="" type="checkbox"/> Machinery Working Group.... Endorsed on: <ul style="list-style-type: none"> 31/01/2018
Question related to: Directive 2006/42/EC Article: Annex: I ESR (1): 1.3.7	EN/prEN: EN 692:2005 +A1:2009; EN 693:2001 +A2:2011 Clause: 5.3.19.2 CEN TC concerned: TC 143	Other: EN ISO 13857:2008; 13849-1:2008; 12100:2010 Other clause:
Key words: Hydraulically actuated clamps		
Question: What is the performance level for the SRP-CS of closing / opening command of hydraulically clamping devices when: Clamps are integrated in the slide (see fig. 1) Clamps are manually positioned (see fig. 2)		
<div style="display: flex; justify-content: space-around;">   </div>		
Solution: If the clamping stroke is higher than 6mm (EN ISO 13857:2008) PLr=c for both conditions EXPLANATION Following EN ISO 12100:2010 and EN ISO 13849-1:2008 S=2 due to the severity of injury F=1 due to the low frequency of the operation and the short duration of the operation P=1 due to marking of residual risk and qualification of the operators Residual risk of the operation can be reduced by additional measures like keeping safety devices (e.g. Light curtain) active during operation.		

(1) Essential safety requirement

Note: According to point 6.6 of the Guide of the implementation of directives based on the New Approach and the Global Approach, the notified bodies apply as general guidance this recommendation for use.

Solution:

If the clamping stroke is higher than 6mm (EN ISO 13857 – 2008)
PLr=c for both conditions

EXPLANATION

Following EN ISO 12100 (2010) and EN ISO 13849-1 (2008)

S=2 due to the severity of injury

F=1 due to the low frequency of the operation and the short duration of the operation

P=1 due to marking of residual risk and qualification of the operators

Residual risk of the operation can be reduced by additional measures like keeping safety devices (eg. Light curtain) active during operation

NOTE: This technical sheet regards only the risk of a person being injured for an uncontrolled movement of the clamping devices during the clamping and unclamping operation.

The clamping movement is considered only perpendicular and/or parallel to the tools plane (as shown in the previous figures).

The risk of failure of the clamping device during slide movement is already covered by EN 692:2005+A1 (2009) / EN 693:2001+A2 (2011) clause 5.3.19.2

	CO-ORDINATION OF NOTIFIED BODIES Machinery Directive 2006/42/EC + Amendment		CNB/M/03.210 Revision 04
Date of first stage: 25/09/2014	To be approved by:		Approved on:
Origin: N.B. 0404	<input checked="" type="checkbox"/> Vertical Group <input checked="" type="checkbox"/> Horizontal Committee To be endorsed by: <input checked="" type="checkbox"/> Machinery Working Group....		24/09/2015 02/12/2015 23/09/2016
Question related to: Directive 2006/42/EC Annex: I	Article: ESR (1): 1.3.2	EN/prEN: EN 692:2005+A1:2009 Clause: 5.2.1.4 CEN TC concerned:	Other: EN Other clause: 5.4.1.1
Key words: servo press / press brake – belt connection between motor and screw			
Question: How can the level of safety be kept on a servo press / press brake if the mechanical brake is placed on the servo motor shaft instead of the lead screw which is connected to the motor with a tooth belt			
Solution: See also CNB/M/03.194rev5 Two belts are needed, both monitored PL"d" (EN ISO 13849-1:2008) for breakage. One belt alone must be able to stop the ram (i.e. be able to transmit the nominal braking force) At least 8 consecutive teeth of each belt must be engaged in the pulley. Mechanical parts of shaft, pulleys, screws and their form fit connections shall be dimensioned according to well proven concepts. NOTE: for technical reasons a fault exclusion can be made for the loss of more than 4 teeth in consecutive raw The annual inspection of the machine would show any premature wear; annual inspection shall be stated in the user manual			

(1) Essential safety requirement

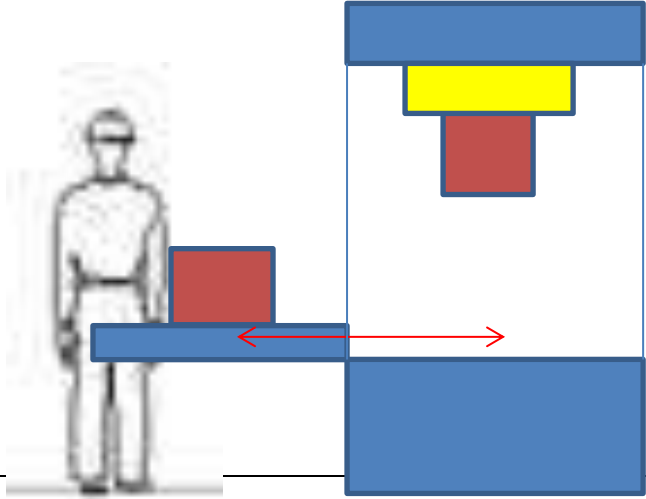
	CO-ORDINATION OF NOTIFIED BODIES Machinery Directive 2006/42/EC + Amendment		CNB/M/03.211 Revision 02
Date of first stage: 25/09/2014	To be approved by:	Approved on:	
Origin: N.B. 0026	<input checked="" type="checkbox"/> Vertical Group	26/09/2014	
	<input checked="" type="checkbox"/> Horizontal Committee	24/06/2015	
	To be endorsed by: <input checked="" type="checkbox"/> Machinery Working Group...	23/09/2016	
Question related to: Directive 2006/42/EC Annex: IV	Article: ESR (1):	EN/prEN: Clause: CEN TC concerned:	Other: Other clause:
Key words: presses – Manual loading/unloading work pieces in presses			
<p>Question:</p> <p>The work piece is manually placed on the lower die, which has been slid outside of the danger zone. When the work cycle starts the lower die first slides inside the danger zone and when in position the upper die moves downwards</p> <p>Are these machines included in annex IV?</p> 			
<p>Solution:</p> <p>NO: if the slide is an integrated auxiliary device of the press (the operator can only place the work piece outside the danger zone)</p> <p>YES: if the cycle gives the operator the possibility to place the work piece between the dies (e.g. two steps cycle)</p> <p>See also CNB/M/03.002 rev 15</p>			

(1) Essential safety requirement

F.1 Principle of interlocking corresponding to type III, using electromechanical components

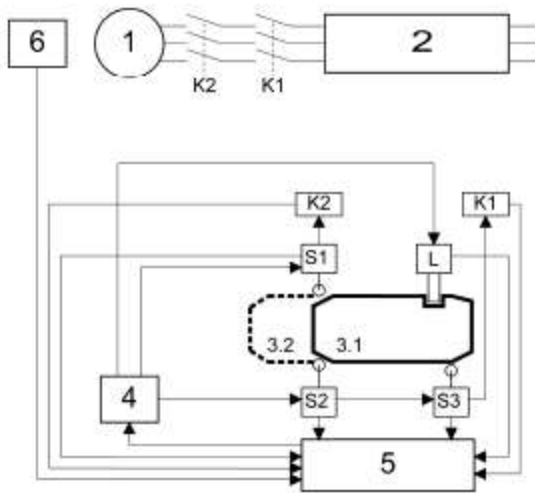

	CO-ORDINATION OF NOTIFIED BODIES Machinery Directive 2006/42/EC + amendments RECOMMENDATION FOR USE		CNB/M/03.214 Revision: 04 Language: EN
Number of pages: 1 Origin: VG3 Presses for cold working metals	Date: 03.07.2023	To be approved by: <input checked="" type="checkbox"/> Vertical Group <input checked="" type="checkbox"/> Horizontal Committee To be endorsed by: <input checked="" type="checkbox"/> Machinery Expert Group	Approved on: 12.09.2019 14.06.2022 Endorsed on: 23.03.2023
Question related to: Directive 2006/42/EC Annex: I	Article: - EHSR (1): 1.2.1	EN/prEN: EN 12622:2009 + A1:2013 Normative clause: - CEN TC concerned: -	Other: EN 60204-1:2018 EN 62745:2017 Other clause: -
Key words: Press brake / Control panel / Wireless			
Question: How it is possible to use a wireless station with safety functions to control press brake movements?			
Solution: The following shall be adopted. 1. Performance level according to EN ISO 13849-1:2015 Table 2 of EN 12622:2009 + A1:2013 shall be applied for the safety level of the various safety functions related to the use of the wireless control station (e.g. Hold to run control, Emergency stop, Reset, etc.). 2. Standard requirements Wireless command shall be compliant with: - clause 9.2.4 of EN 60204-1: 2018; - EN 62745: 2017. 3. Loss of communication The loss of communication shall arrest the machine. In this situation safeguard actions through the remote station could not be operative (e.g. the opening of the press). For this reason, it shall be possible to perform these actions on a control panel fixed to the machine. 4. Response time The response time of the wireless communication shall be evaluated in relation to different safety functions. 5. Range of control The press manufacturer shall define the areas where the wireless control station can be used in a safe way. The NB shall check that from these areas there is complete visibility of the dangerous zones.			

(1) Essential health and safety requirement

Note: According to point 6.6 of the Guide of the implementation of directives based on the New Approach and the Global Approach, the notified bodies apply as general guidance this recommendation for use.

	CO-ORDINATION OF NOTIFIED BODIES Machinery Directive 2006/42/EC RECOMMENDATION FOR USE		CNB/M/03.216 Revision: 04 Language: EN
Number of pages: 1	Date: 03.07.2023	To be approved by:	Approved on:
Origin: VG3 Presses for cold working metals		<input checked="" type="checkbox"/> Vertical Group <input checked="" type="checkbox"/> Horizontal Committee To be endorsed by: <input checked="" type="checkbox"/> Machinery Expert Group	24.05.2022 14.06.2022 Endorsed on: 23.03.2023
Question related to: Directive 2006/42/EC	Article: -	EN/prEN: EN ISO 16092-2:2020	Other: -
Annex: I	EHSR (1): 1.3.7	Normative clause: 5.2.5.3	Other clause: -
Key words: presses with a servo drive system (mechanical servo presses); brakes.			
<p>Question:</p> <p>Several types of brakes are present on the market. For some of them fault exclusion is not possible due, for example, to a specific use on servo-presses. In this case a single fault may lead to a delay of the braking function.</p> <p>Which kind of measures are considered to be applicable and sufficient to detect such fault?</p>			
<p>Solution:</p> <p>Some brakes can be strongly influenced by the specific application. Brakes on servo-presses are subject to other physical influences than conventional mechanical presses; e.g. acceleration values of 1-2 g were measured on drives of mechanical presses, and values up to 16 g on servo-press drives.</p> <p>The following possible solution may be acceptable.</p> <p>In order to allow direct monitoring of those servo-brake components that are moved during switching, these brakes must be equipped with sensors for position-monitoring of components moving during switching, or must be prepared for being equipped with such sensors.</p> <p>During each single cycle an automatic monitoring of the time for the brake activation shall be measured.</p> <p>The time between the activation of the brake (e.g. the switch-off of the electro-valves) and the close position of the brake itself shall be measured and evaluated.</p> <p>If the brake activation time is out of the defined limits the safety control system shall stop the press.</p> <p>The control circuit for the brake monitoring shall have the same Performance Level like the control system/function according to Tables 1 and 2 of the EN ISO 16092-2.</p>			

(1) Essential health and safety requirement

Note: According to point 6.6 of the Guide of the implementation of directives based on the New Approach and the Global Approach, the notified bodies apply as general guidance this recommendation for use.

	CO-ORDINATION OF NOTIFIED BODIES Machinery Directive 2006/42/EC + amendments RECOMMENDATION FOR USE		CNB/M/03.217 Revision: 02 Language: EN
	Number of pages: 1	Date: 03.07.2023	To be approved by: <input checked="" type="checkbox"/> Vertical Group <input checked="" type="checkbox"/> Horizontal Committee To be endorsed by: <input checked="" type="checkbox"/> Machinery Expert Group
Origin: VG3 Presses for cold working metals		EN/prEN: EN ISO 16092-1:2018 Normative clause: 5.4.1.1.3 CEN TC concerned: TC 143 and ISO TC 39/SC 10	Other: - Other clause: -
Question related to: Directive 2006/42/EC	Article: -	Key words: Reset function	
Annex: I	EHSR (1): 1.2.2	Question: Is it allowed to have more than one reset control device for each protection device (interlocked guard or AOPD) of the protected area?	
Solution: Yes, as long as the risk assessment leads to a conclusion of a clear view of the protected area (it would be helpful to save time for the operator, considering also ergonomic aspects). Remark: Clause 5.4.1.1.3 of EN ISO 16092-1 is related to interlocking guards and ESPE using AOPD. The following two sentences in this clause are related to AOPDs only: <i>“There shall not be more than one reset control device for each detection zone. If the press is safeguarded by means of side and back AOPDs, a reset control device shall be provided on each detection zone”</i> .			

(1) Essential health and safety requirement

Note: According to point 6.6 of the Guide of the implementation of directives based on the New Approach and the Global Approach, the notified bodies apply as general guidance this recommendation for use.

	CO-ORDINATION OF NOTIFIED BODIES Machinery Directive 2006/42/CE + Amendment RECOMMENDATION FOR USE	CNB/M/04.034 Revision: 05 Language: E
Date of first stage: 02/12/1999	To be approved by:	Approved on:
Origin: VG4 Injection or compression moulding machine	<input checked="" type="checkbox"/> Vertical Group <input checked="" type="checkbox"/> Horizontal Committee To be endorsed by: <input checked="" type="checkbox"/> Machinery Working Group.....	25/08/2009 02/12/1999 Endorsed on: 09/04/2001
Question related to: Directive 2006/42/EC Annex: I ESR (1): 1.4.2.2	EN/prEN: EN 201:1997 Clause: [(pr)EN]: 5.2.2 CEN TC concerned :	Other:
Key words: Rubber and Plastics injection moulding machine; interlocking of movable guards providing access to the closing mechanism area		
Question: What are the possible solutions for electrical interlock of movable guards of the closing mechanism other than the standard EN 201 requires?		
Solution: a) 1 limit switch operated by a roller level (pos. 1) and 1 tongue switch with separate actuator (pos.2). Pos. 1 is actuated when the guard gate is closed; in pos. 2, the actuator is inserted into the switch when the guard gate is closed. Pos. 2 shall be provided with a coded actuator or a time monitoring shall be provided in such a way that the cycle is interrupted when the actuation is not simultaneous. b) 2 coded toggle switches with separate actuators; when the guard gate is closed, both actuators are inserted into the switch. c) If none coded switches are used time monitoring shall be provided in such a way that the cycle is interrupted when the actuation is not simultaneous. The two switches shall be positioned in such a way, that they can not be actuated simultaneously by one person. Adaptation procedure: FORMAL ADAPTATION IN CONFORMITY WITH DIRECTIVE 2006/42/EC		

(1) Essential safety requirement

Note: According to point 6.6 of the Guide of the implementation of directives based on the New Approach and the Global Approach, the notified bodies apply as general guidance this recommendation for use.

	CO-ORDINATION OF NOTIFIED BODIES Machinery Directive 2006/42/EC + amendments RECOMMENDATION FOR USE		CNB/M/04.053 Revision: 07 Language: EN
Number of pages: 1 Origin: VG 4 Injection and Compression Moulding Machines	Date: 03.07.2023	To be approved by: <input checked="" type="checkbox"/> Vertical Group <input checked="" type="checkbox"/> Horizontal Committee To be endorsed by: <input checked="" type="checkbox"/> Machinery Expert Group	Approved on: 09.06.2021 16.12.2021 Endorsed on: 23.03.2023
Question related to: Directive 2006/42/EC Annex: I	Article: - EHSR (1): 1.2.1	EN/prEN: EN 201:2009 / EN ISO 20430:2020 Normative clause: - / 4.1.2.1 TC concerned: CEN TC 145 / ISO TC 270	Other: - Other clause: -
Key words: 24 VDC hydraulic valves, protective bonding circuit connection on the voltage supply plug of a 24 VDC solenoid valve			
Question: Is it necessary to have a separate grounding wire to each 24 VDC solenoid valve?			
Solution: It is not necessary to have a separate grounding wire to each solenoid valve if all of the following conditions are fulfilled: <ul style="list-style-type: none"> - coils are supplied by separate winding transformer or equivalent - the coil of solenoid is coated in an insulating material - one side of the secondary output is connected to earth - the connector is made of plastic - an interconnection has to be done between the frame and the block supporting the valves either by wiring or by fixing the valves on the frame 			

(1) Essential health and safety requirement

Note: According to point 6.6 of the Guide of the implementation of directives based on the New Approach and the Global Approach, the notified bodies apply as general guidance this recommendation for use.

	CO-ORDINATION OF NOTIFIED BODIES Machinery Directive 2006/42/EC + amendments RECOMMENDATION FOR USE		CNB/M/04.076 Revision: 06 Language: EN
Number of pages: 1	Date: 03.07.2023	To be approved by:	Approved on:
Origin: VG 4 Injection and Compression Moulding Machines		<input checked="" type="checkbox"/> Vertical Group <input checked="" type="checkbox"/> Horizontal Committee To be endorsed by: <input checked="" type="checkbox"/> Machinery Expert Group	09.06.2021 16.12.2021 Endorsed on: 23.03.2023
Question related to: Directive 2006/42/EC	Article: -	EN/prEN: EN 201:2009 / EN ISO 20430:2020	Other: Annex C, G, H / Annex D, E
Annex: I	EHSR (1): 1.2.1	Normative clause: 5.2.1 / 4.2.1.1	Other clause: -
Key words: Plastics and rubber hydraulic IMM – horizontal mould closing movement – motor control unit			
Question: The pump of the hydraulic circuit is driven by an electrical motor and its control unit (frequency converter or contactor). Is it possible to use as second shut-off device, defined in EN 201 / EN ISO 20430 type III, a motor control unit, a frequency converter or a contactor that switches-off the pump drive (the main power source for the horizontal closing movement of the platen) instead of a valve?			
Recommended solution: Yes, provided that: <ul style="list-style-type: none"> • The opening of the guard shall activate the Safe Torque Off function (see definition in EN 61800-5-2:2017) of the motor control unit or switch-off the contactor. • The motor control unit Safe Torque Off function shall comply with the requirements of PL c, category 2 or 3 of EN ISO 13849-1:2015, and shall be tested by an independent laboratory accredited according to EN ISO/IEC 17025. • The contactor shall be directly connected to the motor and with linked or mirror control contacts. • The change of the signal of the switch-off coming from the motor control unit or the contactor shall be automatically monitored at least once during each cycle of the movable guard. • Commencement of any further cycle after closing of the movable guard shall be possible only if no faults have been detected. • The fault of the main shut-off device shall not create a dangerous run-down. • The only power source for the closing movement of the movable platen shall be the pump; no accumulators shall be installed on this line. 			

(1) Essential health and safety requirement

Note: According to point 6.6 of the Guide of the implementation of directives based on the New Approach and the Global Approach, the notified bodies apply as general guidance this recommendation for use.

	CO-ORDINATION OF NOTIFIED BODIES Machinery Directive 2006/42/EC + amendments RECOMMENDATION FOR USE		CNB/M/04.083 Revision: 07 Language: EN
Number of pages: 1	Date: 03.07.2023	To be approved by:	Approved on:
Origin: VG 4 Injection and Compression Moulding Machines		<input checked="" type="checkbox"/> Vertical Group <input checked="" type="checkbox"/> Horizontal Committee	03.05.2022 14.06.2022
		To be endorsed by: <input checked="" type="checkbox"/> Machinery Expert Group	Endorsed on: 23.03.2023
Question related to: Directive 2006/42/EC	Article: -	EN/prEN: EN ISO 20430:2020	Other: -
Annex: I	EHSR (1): 1.5.14	Normative clause: 4.2.7, 4.2.8	Other clause: -
Key words: Injection moulding machines with tie bar distances >1200 mm; person standing behind the mould at the rear side of the machine or entering the mould area from the operator's side			
<p>Question:</p> <p>A machine manufacturer constructs, or retrofits an injection moulding machine having a tie bar distance H >1200mm with a robot on the machine's rear side. In compliance with the standard's specifications, the machine is equipped with an additional safeguarding system in the mould area (e.g. mats). Due to the large dimensions of the enclosed area or the tools installed on site, a person entering the fenced area of the robot from the operator's side or being in the area between the mould and the mobile guard might not be sufficiently visible from the operator's side.</p> <p>What are the measures the machine manufacturer or retrofitter has to take if a situation as the one described above is possible on a machine with H>1200mm?</p> <p>Additional Information: This matter was raised by a machine manufacturer as manufacturers often have to issue the final conformity assessment after having retrofitted a machine at the customer's plant. There is already a data sheet existing which deals with this subject: CNB/M/04.014; however, this data sheet refers exclusively to machines with H<1200mm. Thus, this sheet fails to apply to a dimension of H>1200mm</p> <p>EN ISO 10218-2 describes principals of safety requirement of industrial robot systems and their integration in industrial lines with machines and robot-cells. For alternatives for the safeguarding of the described situation, this standard might be considered.</p>			
<p>Solution:</p> <p>1) A person entering the enclosed area of the robot from the operator's side of the injection moulding machine (IMM) needs to pass an ESPE (mono-beam or multi-beam). Following actuation of this ESPE, an acknowledgment action is necessary at this place before it is possible to start the next machine cycle on the operator's side. An additional pressure-sensitive mat shall be provided on the place where the operator might stay behind the mould between the mould and the rear guard of the machine; this mat shall ensure that although the ESPE has not yet been interrupted the person is detected, and thus prevent initiation of the next machine cycle.</p> <p>or</p> <p>2) A double acknowledgment system as described in EN ISO 20430:2020, Annex F.2 with the first push located at a position from which a good view of the area hidden by the mould and / or the area of the handling device is possible.</p> <p>The acknowledgment procedure has to be required automatically by the control system of the machine every time the safety device in the mould area has been actuated. For that reason, this solution could only be used for machines that usually work in fully automatic mode.</p>			

(1) Essential health and safety requirement

Note: According to point 6.6 of the Guide of the implementation of directives based on the New Approach and the Global Approach, the notified bodies apply as general guidance this recommendation for use.

	CO-ORDINATION OF NOTIFIED BODIES Machinery Directive 2006/42/EC + amendments RECOMMENDATION FOR USE		CNB/M/04.085 Revision: 07 Language: EN
Number of pages: 1	Date: 03.07.2023	To be approved by:	Approved on:
Origin: VG 4 Injection and Compression Moulding Machines		<input checked="" type="checkbox"/> Vertical Group <input checked="" type="checkbox"/> Horizontal Committee To be endorsed by: <input checked="" type="checkbox"/> Machinery Expert Group	03.05.2022 14.06.2022 Endorsed on: 23.03.2023
Question related to: Directive 2006/42/EC	Article: -	EN/prEN: EN ISO 20430:2020	Other: -
Annex: I	EHSR (1): 1.2.1	Normative clause: 4.3.1	Other clause: -
TC concerned: CEN TC 145 / ISO TC 270			
Key words: Mould opening for machines with horizontal closing movement and electrical axis			
<p>Question:</p> <p>Clause 5.3.1 allows the opening movement of the platen when the guards for the mould area are open or the light curtains are interrupted, or the manual actuators of any two hands control device are released. For electrical axis in this situation, a single fault can generally create a change of the direction, because of the bypassing of guard interlocking system, so the opening movement can unexpectedly change to closing movement.</p> <p>How is it possible to prevent that this malfunction can create hazards for machines with horizontal closing movement and electrical axis?</p>			
<p>Solution:</p> <p>To avoid this malfunction the following steps are necessary:</p> <ol style="list-style-type: none"> 1. detection of wrong direction 2a. then stop the movement with a maximum closing distance of 6mm 2b. then remove power or activate the safety function (STO) to prevent unexpected start <p>These steps can be realised by implementing the following circuits:</p> <ul style="list-style-type: none"> • a direction monitoring circuit according to EN ISO 13849-1 PL=e and • a stopping performance monitoring circuit according to EN ISO 13849-1 PL= d • and an axis power removal circuit according to EN ISO 13849-1 PL=e <p>These safety functions can separately be done by a safety device or integrated e.g. in the frequency converter</p> <p>If during the opening movement a wrong direction occurs, than</p> <ol style="list-style-type: none"> 1. the axis shall stop in 6 mm maximum in the worst conditions (mass, speed, etc.) and 2. power removal or safety function (STO) shall be activated. <p>External mechanical brakes can be used. They shall be mechanically linked to the platen using well-tried safety principles. Circuits driving the brake systems shall be designed and monitored according to the needs of the safety control system.</p> <p>Fail safe brake systems shall be used and a test of the brake performance has to be done to show the sufficient friction of the brake. If this test is done in a stand still position, it must be shown that also the stopping time under worst-case conditions will be guaranteed. The interpretation of the test result must be done by the safety control system.</p> <p>The test has to be done</p> <ul style="list-style-type: none"> • at each power on, • at each change of operational mode to enable or disable this function and • after eight hours of operation 			

(1) Essential health and safety requirement

Note: According to point 6.6 of the Guide of the implementation of directives based on the New Approach and the Global Approach, the notified bodies apply as general guidance this recommendation for use.

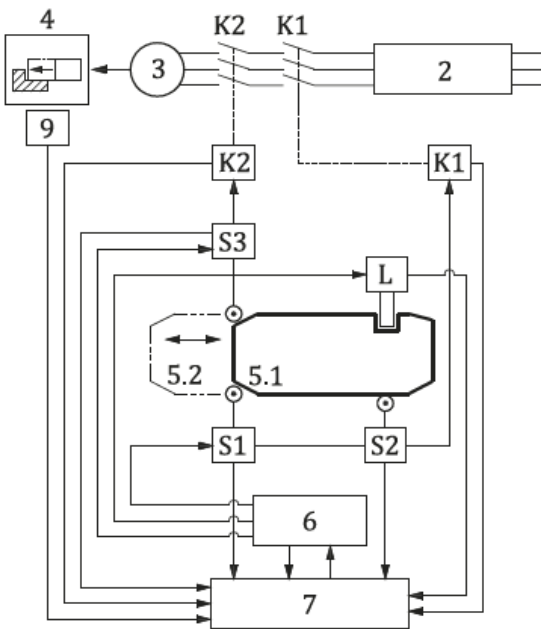
	CO-ORDINATION OF NOTIFIED BODIES Machinery Directive 2006/42/EC + amendments RECOMMENDATION FOR USE		CNB/M/04.086 Revision: 07 Language: EN
Number of pages: 1 Origin: VG 4 Injection and Compression Moulding Machines	Date: 03.07.2023	To be approved by: <input checked="" type="checkbox"/> Vertical Group <input checked="" type="checkbox"/> Horizontal Committee To be endorsed by: <input checked="" type="checkbox"/> Machinery Expert Group	Approved on: 03.05.2022 14.06.2022 Endorsed on: 23.03.2023
Question related to: Directive 2006/42/EC Article: - Annex: I EHSR (1): 1.2.1	EN/prEN: EN ISO 20430:2020 Other: - Normative clause: 4.1.4.3 Other clause: - TC concerned: CEN TC 145 / ISO TC 270		
Key words: Electrical axis; Guard locking; detection of standstill			
Question: For machine with electrical axis, guard locking can be necessary. Clause 4.1.4.3 specifies that the detection of standstill shall be safe against single fault. 1. What is the standstill detection circuit? 2. How can a “permanent automatic monitoring of the change of position of the platen by means of a motor encoder” be safe against single fault?			
Solution: Principal remark: the term “safe against single fault” in the sense of EN ISO 20430:2020; clause 4.1.4.3 describes a dual channel system but does not specify or require a quality of this system. 1. The standstill detection circuit, is the circuit that detects the axis at the rest and gives the signal for the unlocking of the guard. In the example below the standstill detection circuit is composed by: items n.9, n.7, n.6 and signals transmission components.  2. Safe against single fault means, that if the fault of the detection control circuit can unlock the guard when the axis is still moving, the locking device shall be monitored and a stop signal shall be immediately generated for the electrical axes every time the locking device is unlocked.			

(1) Essential health and safety requirement

Note: According to point 6.6 of the Guide of the implementation of directives based on the New Approach and the Global Approach, the notified bodies apply as general guidance this recommendation for use.

	CO-ORDINATION OF NOTIFIED BODIES Machinery Directive 2006/42/EC + amendments RECOMMENDATION FOR USE		CNB/M/04.087 Revision: 06 Language: EN
	Number of pages: 1	Date: 03.07.2023	To be approved by: <input checked="" type="checkbox"/> Vertical Group <input checked="" type="checkbox"/> Horizontal Committee To be endorsed by: <input checked="" type="checkbox"/> Machinery Expert Group
Origin: VG 4 Injection and Compression Moulding Machines		EN/prEN: EN ISO 20430:2020 Normative clause: 4.8.4 TC concerned: CEN TC 145 / ISO TC 270	Other: - Other clause: -
Question related to: Directive 2006/42/EC	Article: -	Key words: Plug and socket combinations for subunits on injection moulding machines	
Annex: I	EHSR (1): 1.5.1	Question: Are plug and socket combinations considered to be physically connected or disconnected during load conditions, if these combinations are only used to connect subunits of the system?	
Solution: The plug and socket combinations are not considered to be physically connected or disconnected during load conditions if the following applies: a) The installation/maintenance manual states that the plug and socket combination shall not be connected or disconnected during load conditions. b) The manufacturer shall describe the procedure for disconnection, for example by the use of <ul style="list-style-type: none"> • The main switch of the injection moulding machine or • A maintenance switch for this circuit of the injection moulding machine or • A switch of the subunit to be connected/disconnected which assures that a current flow is prevented. Note: The requirements of EN 60204-1; cl.13.4.5 shall be fulfilled.			

(1) Essential health and safety requirement

Note: According to point 6.6 of the Guide of the implementation of directives based on the New Approach and the Global Approach, the notified bodies apply as general guidance this recommendation for use.

	<p style="text-align: center;">CO-ORDINATION OF NOTIFIED BODIES Machinery-Directive 2006/42/EC + Amendment</p> <p style="text-align: center;">RECOMMENDATION FOR USE</p>		<p>CNB/M/05.001 Revision 05 Language: E</p>
<p>Date of first stage: 19/01/2001</p> <p>Origin: VG5 Machines for underground work</p>	<p>To be approved by:</p> <p><input checked="" type="checkbox"/> Vertical Group</p> <p><input checked="" type="checkbox"/> Horizontal Committee.....</p> <p>To be endorsed by:</p> <p><input checked="" type="checkbox"/> Machinery Working Group....</p>	<p>Approved on:</p> <p>03/11/2009 07/12/2000</p> <p>Endorsed on :</p> <p>04/01/2005</p>	
<p>Question related to: Directive 2006/42/EC Article:</p> <p>Annex: I ESR (1): 1.5.13</p>	<p>EN/prEN: EN 1679-1:1998</p> <p>Clause:</p> <p>CEN TC concerned:</p>	<p>Other:</p> <p>Other clause:</p>	
<p>Key words: internal combustion engine, emission of dust, gas, exhaust</p>			
<p>Question:</p> <p>What details should a manufacturer give about the hazardous substances in the fume of a diesel engine to be fitted in machines for underground working?</p>			
<p>Solution:</p> <p>In the fume of a diesel engine the following relevant dangerous substances are contained, according to the knowledge of today: Carbon monoxide CO, Carbon dioxide CO₂, Nitrogen oxides NO_x, Hydrocarbons HC, Soot Particles (with carcinogenic substances) PT. Emission limits are described in table 2 of EN 1679-1:1998</p> <p>The manufacturer shall give all the pieces of information to the party that installs the engine/ to the user of the engine, that give them the chance to derive or duplicate the required ventilation rate for the protection of the employees in underground workings. For this, in particular, the values of the measured and calculated emitted loads in g/kW h of the above mentioned dangerous substances are necessary. The calculation of the ventilation rate by the manufacturer of the engine shall be carried out by a mathematical algorithm. Furthermore the manufacturer has to inform the user about the critical values of emissions, which limit that the engine has to be taken out of operation. The notified body shall verify these data.</p> <p>Adaptation procedure: FORMAL ADAPTATION IN CONFORMITY WITH DIRECTIVE 2006/42/EC</p>			

(1) Essential safety requirement

Note: According to point 6.6 of the Guide of the implementation of directives based on the New Approach and the Global Approach, the notified bodies apply as general guidance this recommendation for use.

	CO-ORDINATION OF NOTIFIED BODIES Machinery-Directive 2006/42/EC + Amendment RECOMMENDATION FOR USE		CNB/M/05.002 Revision 05 Language: E
Date of first stage: 19/01/2001	To be approved by :		Approved on :
Origin: VG5 Machines for underground work	<input checked="" type="checkbox"/> Vertical Group <input checked="" type="checkbox"/> Horizontal Committee.....		03/11/2009 07/12/2000
	To be endorsed by: <input checked="" type="checkbox"/> Machinery Working Group....		Endorsed on : 04/01/2005
Question related to: Directive 2006/42/EC Annex: I	Article: ESR (1): 1.5.13	EN/prEN: EN 1889-2:2003 Clause: 5.6.3 CEN TC concerned:	Other: Other clause:
Key words: internal combustion engine, emission of dust, gas, exhaust, methane in intake air			
Question: What details shall a manufacturer give about the hazardous substances that are contained in the exhaust fume of a diesel engine for use in underground working including mines susceptible to firedamp?			
Solution: It is well known, that methane in the intake air negatively influences the emission values of diesel engines. Therefore the manufacturer shall arrange additional tests, in which concentrations of methane of 0,5, 1 and 1,5 Vol. % (see also 5.6.3 EN 1889-2:2003) in the intake air are adjusted. Apart from that CNB/M/05.001/R/E including the whole volume of testing applies.			





Adaptation procedure: FORMAL ADAPTATION IN CONFORMITY WITH DIRECTIVE 2006/42/EC

(1) Essential safety requirement

Note: According to point 6.6 of the Guide of the implementation of directives based on the New Approach and the Global Approach, the notified bodies apply as general guidance this recommendation for use.

	CO-ORDINATION OF NOTIFIED BODIES Machinery-Directive 2006/42/EC + Amendment RECOMMENDATION FOR USE		CNB/M/05.007 Revision 04 Language: E
	Date of first stage: 19/01/2001 Origin: VG5 Machines for underground work	To be approved by: <input checked="" type="checkbox"/> Vertical Group <input checked="" type="checkbox"/> Horizontal Committee..... To be endorsed by: <input checked="" type="checkbox"/> Machinery Working Group....	Approved on: 03/11/2009 07/12/2000 Endorsed on : 04/01/2005
Question related to: Directive 2006/42/EC Annex: I	Article: ESR (1): 1.5.13	EN/prEN: EN 1679-1:1998 Clause: 6.19 CEN TC concerned:	Other: Other clause:
Key words: internal combustion engine, emission of dust, gas, exhaust, limits			
Question: Are the limits for emission of toxic substances in the exhaust gas of internal combustion engines given in clause 6.19 of EN 1679-1 : 1998 acceptable?			
Solution: EN 1679-1:1998 is not sufficient for motors for underground mining, because the limits given there for emission of hazardous substances in the exhaust gas are considered for environmental protection and not suitable for protection of human health. It makes no sense that motors with engine power < 37 kW have to keep no limits. In each case it is necessary to determine the real loads of the hazardous substances e.g. according to CNB/M/05.001 and CNB/M/05.002 so that the user is able to realise that the engine can be used in underground with appropriate ventilation rate.			
Adaptation procedure: FORMAL ADAPTATION IN CONFORMITY WITH DIRECTIVE 2006/42/EC			

(1) Essential safety requirement
 Note: According to point 6.6 of the Guide of the implementation of directives based on the New Approach and the Global Approach, the notified bodies apply as general guidance this recommendation for use.

		<p>CO-ORDINATION OF NOTIFIED BODIES Machinery-Directive 2006/42/EC + Amendment</p> <p>RECOMMENDATION FOR USE</p>		<p>CNB/M/05.201 Revision 03 Language: E</p>	
Date of first stage: 23/06/1997		To be approved by :		Approved on :	
Origin: VG5 Machines for underground work		<input checked="" type="checkbox"/> Vertical Group <input checked="" type="checkbox"/> Horizontal Committee.....		03/11/2009 13/12/1995	
		To be endorsed by:		Endorsed on :	
		<input checked="" type="checkbox"/> Machinery Working Group....		04/06/1996	
Question related to: Directive 2006/42/EC		Article:		EN/prEN:	
Annex: IV, 12.2		ESR (1):		Other:	
				Other clause:	
		CEN TC concerned:			
Key words: Hydraulic powered roof support					
<p>Question:</p> <p>Which types of machine are classed as "hydraulic powered roof supports"?</p>					
<p>Solution:</p> <p>Types of machines classed as "hydraulic powered roof supports" are :</p> <ul style="list-style-type: none">  one support unit under adjacent control  several support units under group control  entire coal face support under central control <p>Coal-getting machines and hoisting engines are excluded.</p>					
<p>Adaptation procedure: FORMAL ADAPTATION IN CONFORMITY WITH DIRECTIVE 2006/42/EC</p>					

(1) Essential safety requirement

Note: According to point 6.6 of the Guide of the implementation of directives based on the New Approach and the Global Approach, the notified bodies apply as general guidance this recommendation for use.

	CO-ORDINATION OF NOTIFIED BODIES Machinery-Directive 2006/42/EC + Amendment RECOMMENDATION FOR USE	CNB/M/05.202 Revision 02 Language : E	
Date of first stage: 30/05/1995	To be approved by :	Approved on :	
Origin: VG5 Machines for underground work	<input checked="" type="checkbox"/> Vertical Group <input checked="" type="checkbox"/> Horizontal Committee..... To be endorsed by: <input checked="" type="checkbox"/> Machinery Working Group....	03/11/2009 13/12/1995 Endorsed on : 04/06/1996	
Question related to: Directive 2006/42/EC	Article:	EN/prEN:	Other:
Annex:	ESR (1):	Clause:	Other clause:
CEN TC concerned:			
Key words: Hydraulic powered roof support, components with safety function, safety components			
Question: Which are the components with safety function/safety components for hydraulic powered roof support?			
Solution: safety components - examples support units: canopy, gob shield, base etc. hydraulic rams: rams, adjusting cylinders, canopy cylinders hydraulic control devices: check valves, pressure limitation valves (yield valves), control valves for setting props, retracting, alignment, advancing electro hydraulic control devices: discrete control devices, emergency off devices, sensors which initiate movements, master control devices, software Adaptation procedure: FORMAL ADAPTATION IN CONFORMITY WITH DIRECTIVE 2006/42/EC			

(1) Essential safety requirement

Note: According to point 6.6 of the Guide of the implementation of directives based on the New Approach and the Global Approach, the notified bodies apply as general guidance this recommendation for use.

	CO-ORDINATION OF NOTIFIED BODIES Machinery-Directive 2006/42/EC + Amendment RECOMMENDATION FOR USE	CNB/M/05.208 Revision 03 Language: E	
Date of first stage: 23/06/1997	To be approved by :	Approved on :	
Origin: VG5 Machines for underground work	<input checked="" type="checkbox"/> Vertical Group <input checked="" type="checkbox"/> Horizontal Committee..... To be endorsed by: <input checked="" type="checkbox"/> Machinery Working Group....	03/11/2009 12/12/1995 Endorsed on : 04/06/1996	
Question related to: Directive 2006/42/EC	Article:	EN/prEN:	Other:
Annex:	ESR (1):	Clause:	Other clause:
CEN TC concerned:			
Key words: Hydraulic powered roof support, placing on the market, putting into service			
Question: What are the most common manufacturing, modification and repair combinations by which new/modified or used hydraulic powered roof supports are placed on the market ?			
Solution: Placing on the market, putting into service of hydraulic powered roof supports: Cases a) new hydraulic powered roof support one manufacturer b) new hydraulic powered roof support several manufacturers c) used hydraulic powered roof support original manufacturer modifies type d) used hydraulic powered roof support non-original manufacturer modifies type e) unchanged type of hydraulic powered roof support authorized before 01-01-95 is placed on the market anew. Adaptation procedure: FORMAL ADAPTATION IN CONFORMITY WITH DIRECTIVE 2006/42/EC			

(1) Essential safety requirement

Note: According to point 6.6 of the Guide of the implementation of directives based on the New Approach and the Global Approach, the notified bodies apply as general guidance this recommendation for use.

	CO-ORDINATION OF NOTIFIED BODIES Machinery-Directive 2006/42/EC + Amendment RECOMMENDATION FOR USE	CNB/M/05.220 Revision 05 Language: E
Date of first stage: 19/01/2001 Origin: VG5 Machines for underground work	To be approved by: <input checked="" type="checkbox"/> Vertical Group <input checked="" type="checkbox"/> Horizontal Committee..... To be endorsed by: <input checked="" type="checkbox"/> Machinery Working Group....	Approved on: 03/11/2009 07/12/2000 Endorsed on : 04/01/2005
Question related to: Directive 2006/42/EC Article: Annexes: IV, 12.2, IX ESR (1):	EN/prEN: Clause: CEN TC concerned:	Other: Other clause:
Key words: Hydraulic powered roof support, support unit, technical file, EC-type examination		
Question: What is a representative model for the EC-type examination procedure of different types of hydraulic powered roof support machinery?		
Solution: 1) New hydraulic powered roof support as a whole or parts of it have to comply in any case with all applicable requirements of the directive before being placed on the market (e.g. EC-type examination if harmonised standards are not used). 2) In the case of replacement of components with safety function of hydraulic powered roof supports like legs, hydraulic control system or structural steel elements, which do not change the function, the person who replaces the components of the machine shall ensure the compatibility of these components. The replaced component shall be type tested and a certificate shall be issued by a notified body. A new EC-type examination certificate for the entire machine is not necessary. 3) In the case of replacement of components which change the function of the machine (e.g. changing of the media bearing force, automation of motions, change of dimensions) a new EC-type examination certificate is required. The tests required shall be specified in each case. Generally the tests cover the components themselves, the respective interfaces and the changes of function caused thereby. 4) New hydraulic powered roof support machines require EC-type examination certificates before they may be placed on the market regardless of whether identical machines placed on the market before January 1, 1995 had been homologated by a national authority. Existing test reports shall be recognised. The extend of additional tests and the documentation required shall be specified in each case. 5) The application for an EC-type examination shall include the following documentation: - for support units according to recommendation for use CNB/M/05.204/R/E, rev. 02, 19.11.1996 - for hydraulic control systems and valves according to recommendation for use CNB/M/05.205/R/E, rev. 02, 19.11.96 - for electro hydraulic control systems and components according to recommendation for use CNB/M/05.206/R/E, rev 02, 19.11.1996 - for legs and rams within the flow of the media bearing force according to recommendation for use CNB/M/05.207, rev. 02, 19.11.1996 Adaptation procedure: FORMAL ADAPTATION IN CONFORMITY WITH DIRECTIVE 2006/42/EC		

(1) Essential safety requirement

Note: According to point 6.6 of the Guide of the implementation of directives based on the New Approach and the Global Approach, the notified bodies apply as general guidance this recommendation for use.

	<p>CO-ORDINATION OF NOTIFIED BODIES Machinery-Directive 2006/42/EC + Amendment</p> <p>RECOMMENDATION FOR USE</p>		<p>CNB/M/05.603 Revision 05 Language: E</p>
<p>Date of first stage: 19/01/2001</p>	<p>To be approved by:</p>		<p>Approved on:</p>
<p>Origin: VG5 Machines for underground work</p>	<p><input checked="" type="checkbox"/> Vertical Group</p> <p><input checked="" type="checkbox"/> Horizontal Committee.....</p>		<p>03/11/2009 07/12/2000</p>
<p>To be endorsed by:</p>			<p>Endorsed on :</p>
<p><input checked="" type="checkbox"/> Machinery Working Group....</p>		<p>04/01/2005</p>	
<p>Question related to: Directive 2006/42/EC</p>	<p>Article:</p>	<p>EN/prEN:</p>	<p>Other:</p>
<p>Annex: I</p>	<p>ESR (1):</p>	<p>Clause:</p>	<p>Other clause:</p>
<p>CEN TC concerned:</p>			
<p>Key words: locomotive, EC type examination certificate, putting into operation, control</p>			
<p>Question: Is it possible for a notified body to prescribe in his certificate (or test report) for a locomotive the way of putting into operation and the type of control?</p>			
<p>Solution: A notified body may require the instructions to include details of putting into operation and the type of control if this can affect the safe working of a locomotive.</p>			
<p>Adaptation procedure: FORMAL ADAPTATION IN CONFORMITY WITH DIRECTIVE 2006/42/EC</p>			

(1) Essential safety requirement

Note: According to point 6.6 of the Guide of the implementation of directives based on the New Approach and the Global Approach, the notified bodies apply as general guidance this recommendation for use.

	<p style="text-align:center">CO-ORDINATION OF NOTIFIED BODIES Machinery-Directive 2006/42/EC + Amendment</p> <p style="text-align:center">RECOMMENDATION FOR USE</p>	<p>CNB/M/05.604 Revision 05 Language: E</p>
Date of first stage: 19/01/2001	To be approved by:	Approved on:
Origin: VG5 Machines for underground work	<input checked="" type="checkbox"/> Vertical Group <input checked="" type="checkbox"/> Horizontal Committee.....	03/11/2009 07/12/2000
	To be endorsed by:	Endorsed on :
	<input checked="" type="checkbox"/> Machinery Working Group....	04/01/2005
Question related to: Directive 2006/42/EC Article: Annex: IV 12.1 ESR (1):	EN/prEN: Clause: CEN TC concerned:	Other: Other clause:
Key words: locomotive, definition		
Question: What is a locomotive for underground working?		
Solution: A locomotive is a self-powered uncaptivated vehicle running on a track of one or two rails underground in mines or other underground workings, designed for hauling or transporting persons, materials or mineral. Usually the rails are situated above or under the vehicle.		
Adaptation procedure: FORMAL ADAPTATION IN CONFORMITY WITH DIRECTIVE 2006/42/EC		

(1) Essential safety requirement

Note: According to point 6.6 of the Guide of the implementation of directives based on the New Approach and the Global Approach, the notified bodies apply as general guidance this recommendation for use.

The footboard shall be secure against unintended folding down which can cause an unintended braking down. When folding is powered the powering force shall be limited to 75 N measured at any point where a person can stand on. The folding speed measured at the rear of the footboard shall not exceed 0,6 m/sec. Thus to avoid injuries to the operative's leg when getting off the footboard and the relevant control is activated. The operation control shall be of hold-to-run-type and shall be located at the rear wall of the tailgate and in the cab.

2.1.2 weight indication:

In case of weight indication the restrictions shall be effective when a vertical force of at least 300 N acts onto the footboard totally folded down or its carrying structure in a minimum distance away from the pivoting hinge as a foot can stand on. Riding on the moveable footboard carrying structure when the footboard is folded down as well as on the fix carrying structure in any case shall be prevented by design. Easy bypassing the weight indication by supporting the footboard by means of a rope, chain, etc. or blocking it in a position not folded out totally shall be prevented by the design. The weight indication will only be accepted when the capability of easy bypassing, e. g. as mentioned above is permanently prevented.

The weight detection shall be effective at any temperature the RCV is designed for as stated in the "information for use" (operator's manual) with no drift of the forces. The period of necessary readjustment shall be stated in the "information for use" (operator's manual) and should not be less than the normal inspection period given in the user's manual.

Further more there shall no facility in easy reach of the footboard where on the operative can support himself to reduce his weight force acting on the footboard.

2.1.3 space indication

In case of space indication the operative shall be detected at any position on the footboard or its carrying structure independent from his cloth's colour and performance. Nothing else than a person positioned on the footboard shall be detected particularly other traffic participants (vehicles or pedestrians) or the road itself, when the footboard is folded down.

The space indication shall be effective at any temperature the RCV is designed for as stated in the "information for use" (operator's manual) with no drift of the detected area and no reduce of the detecting sensitivity.

2.1.4 Braking requirements for systems as described under 2.1.1 to 2.1.3:

Jumping onto the footboard during reversing up to 6 km/h shall stop the RCV within the distance between the rear edge of the footboard and the rear point of the rear wheel (see figure below).

At higher speeds the braking shall also be activated and the stopping distance may become longer but as short as possible.

This shall be measured on a dry horizontal even ground.

2.2 Restrictions

When one or both footboards are detected as occupied following restrictions shall apply:

- speed limitation on forward motion of the RCV up to 30 km/h, tested by means of the chassis own tachograph.
- prevention of reverse of the RCV in any case (see RFU 06.031).
- prevention of operating the lifting device when provided. This does not apply when the risk of unintentionally being crushed or sheared is prevented by a sufficient safeguard.
- prevention of operating the compaction mechanism in the automatic mode on an open system according to EN 1501-1.
- after use of the footboard automatic restart of bodywork or chassis functions shall be prevented.

(See also EN 1501-1)

2.3 Monitoring control:

2.3.1 Examining that part of the monitoring control which is origin part of the chassis is not task of the notified body performing an EC-type-examination. It shall only be tested according to its function.

2.3.2 The entire control including the detectors shall be designed not to be rendered ineffectively or to set out of operation by simple tools according to EN 1088. Particularly cutting a wire, disconnecting a plug connection out of a screwed box, removal of a detector, shadow respective making blind a sensor for space indication, and a failure of one component of the footboard monitoring control shall lead to the restrictions be effective (One failure safe). This shall be in accordance with the category 3 of the standard EN ISO 13849-1:2008.

To avoid manipulation, the check of the footboard control shall be made after each engine stop, at least before the compaction mechanism or /and the lifting device can be started. This check may not be the precondition for the chassis to drive faster than 30 km/h.

2.3.3 Environmental influences e.g. spot lights, part of trees approach of other vehicles, shall not lead to the restrictions be effective.

2.3.4 Cables and wires out of boxes shall withstand the environmental influences and shall be protected against mechanical damages. Components located on the outer surface of the RCV shall comply with IP 65 according to EN 60529+A1:2002.

2.3.5 To enable reverse in case of the monitoring system is destroyed e.g. by a traffic accident a push button shall be provided in the cab which bypasses the reverse restriction and prevents the operation of the bodywork including lifting device. Resetting shall only be possible by a key which shall not be identically with the ignition key or the cab door key. The push button shall be sealed. The "information for Use"

(operator's manual) shall state that the key shall be separated from the RCV. Resetting the push button it shall take at least 5 minutes before the RCV is ready for use again.

2.4 Communications

The working area needed to be observed including the footboards. Therefore the Closed Circuit Television System (CCTV) mentioned in 5.12.1. of EN 1501-1 shall not be capable of switching off during work and transport at any time when the ignition key is switched on.

2.5 Warning

To avoid traffic accidents by the slow going vehicle the flashing beacon according to 7.1.2.2 of prEN 1501-1: 2011 shall be engaged automatically when the footboards are occupied or the bodywork is switched on.

(National traffic rules shall be considered)

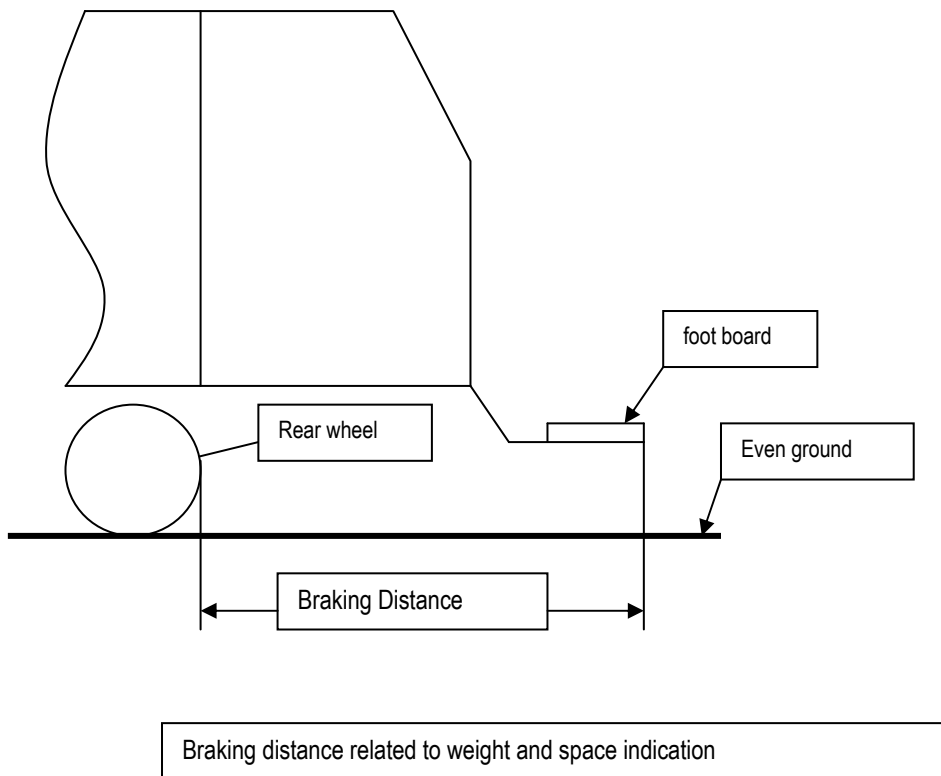

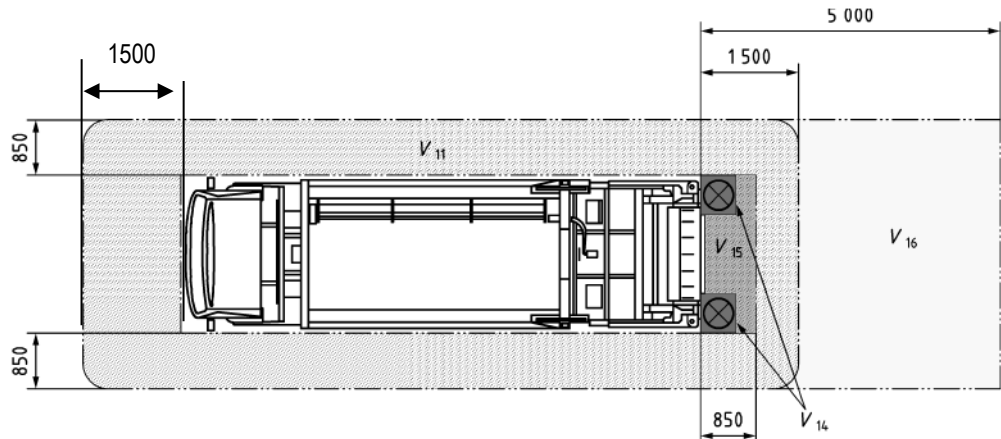
	CO-ORDINATION OF NOTIFIED BODIES Machinery Directive 2006/42/EC + amendments RECOMMENDATION FOR USE		CNB/M/06.047 Revision: 02 Language: EN
Number of pages: 1	Date: 03.07.2023	To be approved by:	Approved on:
Origin: VG6 Refuse collection vehicles		<input checked="" type="checkbox"/> Vertical Group <input checked="" type="checkbox"/> Horizontal Committee To be endorsed by: <input checked="" type="checkbox"/> Machinery Expert Group	02.06.2021 16.12.2021 Endorsed on: 23.03.2023
Question related to: Directive 2006/42/EC	Article: 1.1.2	EN/prEN: 1501-1:2021	Other: -
Annex: -	EHSR (1): -	Normative clause: 5.2 CEN TC concerned: TC 183 WG2	Other clause: -
Key words: Danger zone / Visibility / testing			
Question: How to ensure and evaluate the danger zone as described in EN1501-1 clause 5.2.2			
Solution: Visibility test should be done without any obstacle in the evaluated danger zones. Verification measurement shall be made with a vertical test object of 1,2 m height with a suitable width of 150 mm. For each danger zone identified in the following schematics, it shall be checked whether the test object is visible or detectable from the driver position or the operator working station on the whole boundary of the zone. The test object is considered to be visible in the following conditions: <ul style="list-style-type: none"> - There is no masking, or - Masking is smaller or equal to 200 mm height length. Note: masking smaller or equal to 200mm height length means an object higher than 1m is visible.			
			

(1) Essential health and safety requirement

Note: According to point 6.6 of the Guide of the implementation of directives based on the New Approach and the Global Approach, the notified bodies apply as general guidance this recommendation for use.

	CO-ORDINATION OF NOTIFIED BODIES Machinery Directive 2006/42/EC + amendments RECOMMENDATION FOR USE		CNB/M/08.001 Revision: 04 Language: EN
Number of pages: 1 Origin: VG8 Vehicles servicing lifts	Date: 23.06.1997	To be approved by: <input checked="" type="checkbox"/> Vertical Group <input checked="" type="checkbox"/> Horizontal Committee To be endorsed by: <input checked="" type="checkbox"/> Machinery Expert Group	Approved on: 12.04.2010 13.12.1995 Endorsed on: 04.06.1996
Question related to: Directive 2006/42/EC Annex: -	Article: - EHSR (1): -	EN/prEN: pr EN 1493 Normative clause: 5.6.5.6 CEN TC concerned: TC 98 WG 3	Other: - Other clause: -
Key words: Polyamide Nuts			
Question: With regard to screw drives red brass or bronze are the most common materials for the load bearing nut and the safety nut as written in the comments of the German prevention rule VBG 14. However, some manufacturers intend to use polyamide for the load bearing nut. Some tests in our institute have shown that polyamide nuts can have the same or even a better tribological behaviour than bronze nuts, e.g. with regard to self-locking and self-retarding. Is it allowed to use polyamide nuts in vehicle lifts? Do the other NB's have any experiences with these nuts, especially when the lubricant is contaminated with dirt or particles (e.g. swarf)?			
Solution: Polyamide nuts may be used in vehicle lifts, provided that lifetime tests have been carried out. The technical should <ul style="list-style-type: none"> • describe the conditions for this test which should include • carrying out min. 30000 load cycles (nominal load), which relates to a life time of 10 years. A safety factor of 6 against breaking shall be used.			

(1) Essential health and safety requirement

Note: According to point 6.6 of the Guide of the implementation of directives based on the New Approach and the Global Approach, the notified bodies apply as general guidance this recommendation for use.

	CO-ORDINATION OF NOTIFIED BODIES Machinery Directive 2006/42/EC + amendments RECOMMENDATION FOR USE		CNB/M/08.002 Revision: 04 Language: EN
Number of pages: 1 Origin: VG8 Vehicles servicing lifts	Date: 03.07.2023	To be approved by: <input checked="" type="checkbox"/> Vertical Group <input checked="" type="checkbox"/> Horizontal Committee To be endorsed by: <input checked="" type="checkbox"/> Machinery Expert Group	Approved on: 12.04.2010 09.12.1998 Endorsed on: 03.03.2000
Question related to: Directive 2006/42/EC Annex: -	Article: - EHSR (1): -	EN/prEN: - Normative clause: - CEN TC concerned: -	Other: - Other clause: -
Key words: EC Type Test			
Question: How do we proceed, when the EC-type test refers to a group of machines (vehicle lifts) with the same design features and merely different load-carrying capacities? Do we have to test each machine (vehicle lift) or is it sufficient to test the type with minimum and/or maximum bearing capacity?			
Solution: Each type of vehicle lift has to be tested and compliance with the ESR'S of MD has to be confirmed by the NB. The extent of test can be reduced in case of similar equipment by responsibility of the NB. (see also CNB/M/03.009)			

(1) Essential health and safety requirement

Note: According to point 6.6 of the Guide of the implementation of directives based on the New Approach and the Global Approach, the notified bodies apply as general guidance this recommendation for use.

	CO-ORDINATION OF NOTIFIED BODIES Machinery Directive 2006/42/EC + amendments RECOMMENDATION FOR USE		CNB/M/08.003 Revision: 05 Language: EN
Number of pages: 2 Origin: VG8 Vehicles servicing lifts	Date: 03.07.2023	To be approved by: <input checked="" type="checkbox"/> Vertical Group <input checked="" type="checkbox"/> Horizontal Committee To be endorsed by: <input checked="" type="checkbox"/> Machinery Expert Group	Approved on: 12.04.2010 09.12.1998 Endorsed on: 03.03.2000
Question related to: Directive 2006/42/EC Annex: -	Article: - EHSR (1): -	EN/prEN: EN ISO 12100-2:2003 Normative clause: - CEN TC concerned: -	Other: - Other clause: -
Key words: instruction handbook, check			
Question: Is it necessary within the EC-type test to examine the content of the instruction handbook in detail or is it sufficient to check the handbook only in a formal way e.g. with regard to chapter 6 of EN 12100-2:2003?			
Solution: Notified bodies shall examine the safety relevant content of the instruction handbook (content see EN 12100-2 clause 6). Details for vehicle lifts are e.g. (see next page).			

(1) Essential health and safety requirement

Note: According to point 6.6 of the Guide of the implementation of directives based on the New Approach and the Global Approach, the notified bodies apply as general guidance this recommendation for use.

Details for vehicle lifts (cont.)

- Information about the product:
 - name of manufacturer, importer or dealer,
 - type designation of product,
 - date of issue of the instruction manual, status,
 - address of manufacturer, address of authorized representative,
 - technical ratings of the vehicle lift (load, load distribution, height),
 - intended use (lifting of cars), inappropriate use (lifting of people), special applications
 - available equipment options (wheel free systems, alignment systems),
 - weight and dimensions,
 - special properties (e.g. Ex proof),
 - noise and other emissions.

- Information about installation:
 - limitations of environmental ambient conditions (temperature, humidity, water),
 - required floor conditions (strength, preparation),
 - electrical supply requirements (voltage, current, supply cable size, starting current, fusing),
 - hydraulic supply requirements (max. pressure, oil quality and amounts),
 - pneumatic supply requirements (max. pressure),
 - means the user has to provide (power system, mains switch, guards),
 - final checks.

- Information about the use
 - description of controls (raising, lowering),
 - description of safety devices (safety catch, levelling system, emergency stop, rope or chain failure),
 - adjustment procedures (if any),
 - emergency stop procedures, restarting.
 - operating modes (independent / common control), safety features in different operating modes,
 - protection against unauthorized use (use of key switches),
 - rules for handling of special conditions (after tripping of protective devices, emergency lowering)
 - warning of dangerous parts (high voltage, high pressure),
 - error handling procedures (tripping of fuses, desynchronisation),
 - charging of batteries (ventilation),
 - safety instructions (e.g. no persons under the lift during movement),
 - authorization for operating.

- Maintenance and repair
 - necessary spare parts,
 - service intervals,
 - special safety precautions during maintenance and repair,
 - safety inspections and tests.

- User information
 - parts lists (electrical, hydraulic, pneumatic),
 - schematics (electrical, hydraulic, pneumatic),
 - pictures, photos, exploded view

	CO-ORDINATION OF NOTIFIED BODIES Machinery Directive 2006/42/EC + amendments RECOMMENDATION FOR USE		CNB/M/08.008 Revision: 03 Language: EN
Number of pages: 1	Date: 25.10.1996	To be approved by:	Approved on:
Origin: VG8 Vehicles servicing lifts		<input checked="" type="checkbox"/> Vertical Group <input checked="" type="checkbox"/> Horizontal Committee To be endorsed by: <input checked="" type="checkbox"/> Machinery Expert Group	12.04.2010 17.04.1996 Endorsed on: 08.06.1998
Question related to: Directive 2006/42/EC	Article: -	EN/prEN: pr EN 1493 N12	Other: -
Annex: -	EHSR (1): -	Normative clause: - CEN TC concerned: TC 98 WG 3	Other clause: -
Key words: Auxiliary Lifting Systems			
<p>Question:</p> <p>Safety requirements for auxiliary lifting systems installed on vehicle lifts: Are safety devices for preventing</p> <ul style="list-style-type: none"> • desynchronisation of lifting and lowering, • inadvertent lowering in case of a failure in the lifting system <p>also required for these systems?</p>			
<p>Solution:</p> <p>For auxiliary lifting systems on vehicle lifts the same safety devices are required as necessary for the vehicle tilts. The reason for that are hazards to be taken into consideration from</p> <ul style="list-style-type: none"> • positioning the head and arms by manipulations in upper position of the lift • lifting vehicles without wheels in case of using auxiliary lifts. 			

(1) Essential health and safety requirement

Note: According to point 6.6 of the Guide of the implementation of directives based on the New Approach and the Global Approach, the notified bodies apply as general guidance this recommendation for use.

	CO-ORDINATION OF NOTIFIED BODIES Machinery Directive 2006/42/EC + amendments RECOMMENDATION FOR USE		CNB/M/08.015 Revision: 03 Language: EN
Number of pages: 1	Date: 13.11.2000	To be approved by:	Approved on:
Origin: VG8 Vehicles servicing lifts		<input checked="" type="checkbox"/> Vertical Group <input checked="" type="checkbox"/> Horizontal Committee To be endorsed by: <input checked="" type="checkbox"/> Machinery Expert Group	12.04.2010 11.12.2003 Endorsed on: 01.07.2004
Question related to: Directive 2006/42/EC	Article: -	EN/prEN: EN 1493:1998	Other: -
Annex: -	EHSR (1): -	Normative clause: 5.16.3	Other clause: -
		CEN TC concerned: TC 98 WG 3	
Key words: Rails, foot protectors, protection against pinching points			
Question: How shall foot protectors to be designed?			
Solution: The design shall take into account that a person may step on it in the ground position, without loosing its safety function. It does not to be designed to withstand an obstruction when lowering.			

(1) Essential health and safety requirement

Note: According to point 6.6 of the Guide of the implementation of directives based on the New Approach and the Global Approach, the notified bodies apply as general guidance this recommendation for use.

	CO-ORDINATION OF NOTIFIED BODIES Machinery Directive 2006/42/EC + amendments RECOMMENDATION FOR USE		CNB/M/08.016 Revision: 03 Language: EN
Number of pages: 1	Date: 06.05.2002	To be approved by:	Approved on:
Origin: VG8 Vehicles servicing lifts		<input checked="" type="checkbox"/> Vertical Group <input checked="" type="checkbox"/> Horizontal Committee To be endorsed by: <input checked="" type="checkbox"/> Machinery Expert Group	12.04.2010 11.12.2003 Endorsed on: 01.07.2004
Question related to: Directive 2006/42/EC	Article: -	EN/prEN: EN 1493:1998	Other: -
Annex: -	EHSR (1): -	Normative clause: 5.6.4.2 CEN TC concerned: TC 98 WG 3	Other clause: -
Key words: Chassis supporting vehicle lift for road vehicles, load distribution			
Question: Is it acceptable to use load distribution plates and impose restriction on positioning of road vehicle on the lift (for example restriction on the vehicle direction) when lifting?			
Solution: NO. The calculations for a chassis supporting vehicle lift shall be carried out in the most unfavourable configuration, in order to meet the essential health and safety requirements of the Machinery Directive. For structural design purposes vehicle positioning on load carrying devices shall be considered in both directions. Restriction on the vehicle direction given in load distribution plates and in the instructions of the lifts for normal road vehicles do not meet the principles of safety integration of Machinery Directive. Restrictions may only be allowed for special vehicle lifts (e.g. for fork lift trucks, dumpers, rail bound vehicles etc. according to the clause 5.6.4.3 of EN 1493:1998+A1).			

(1) Essential health and safety requirement

Note: According to point 6.6 of the Guide of the implementation of directives based on the New Approach and the Global Approach, the notified bodies apply as general guidance this recommendation for use.

	CO-ORDINATION OF NOTIFIED BODIES Machinery Directive 2006/42/EC + amendments RECOMMENDATION FOR USE		CNB/M/08.018 Revision: 05 Language: EN
Number of pages: 2 Origin: VG8 Vehicles servicing lifts	Date: 03.07.2023	To be approved by: <input checked="" type="checkbox"/> Vertical Group <input checked="" type="checkbox"/> Horizontal Committee To be endorsed by: <input checked="" type="checkbox"/> Machinery Expert Group	Approved on: 25.04.2013 26.06.2013 Endorsed on: 22.11.2013
Question related to: Directive 2006/42/EC Annex: I	Article: - EHSR (1): 1.1.2.	EN/prEN: EN 1493:2010 Normative clause: 5.7.4.3. a) and b) CEN TC concerned: CEN TC 98	Other: - Other clause: -
Key words: Load distribution on two post lifts with load-bearing arms			
Question: Is it necessary for two post lifts, where both arms of one column could swing in the same direction, to consider this position for the stability and strengths calculation? Has the manufacture take into account such a manner of use as normal use ore as foreseeable misuse in accordance with the machinery directive section 1.1.2. annex 1.			
Solution: The standard requires that the long arms must be in the maximum telescoped position with a width of 1 m of the pick-up points. The short arms should be "in the position which gives the worst condition". Normally, vehicles are raised so that the center of gravity is close to the connecting line between the two lifting columns. But there are many vehicle servicing lifts where it is possible to raise a vehicle with all four arms pivoted in the same direction (see figure 1). Especially at asymmetric two post lifts or lifts with double swing arms, it is possible, to reach such a position and to lift vehicles.			

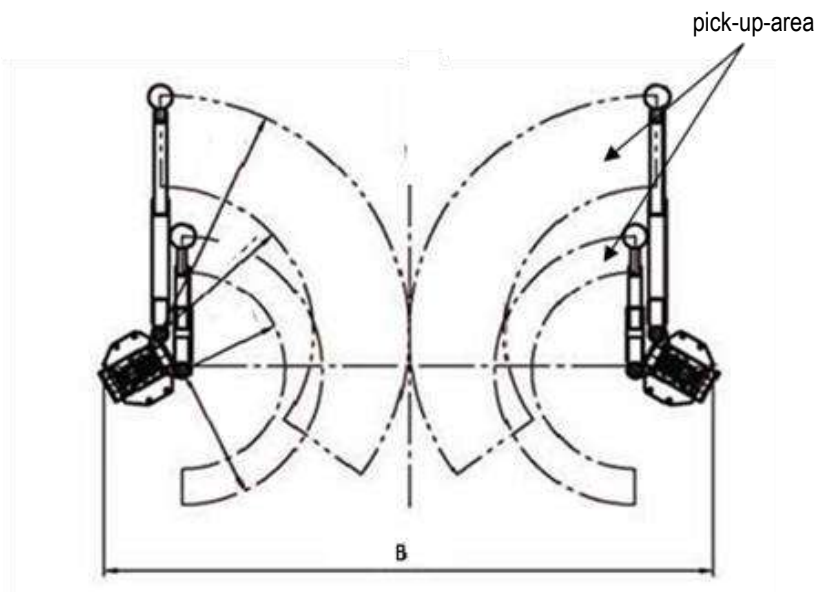

Figure 1 asymmetric post lift

Do to the position centre of gravity of the load the bending moment is significantly larger than during pick up a vehicle in a central position where the arms of the post are pivoted in different directions. Due to the very different design of the mounting points of the various vehicles and the differences in design of the lifts, it is very difficult to assess which vehicles can be lifted in detail. The practice shows, that especially smaller cars can be lifted in such a position.

Solution:

The answer to both questions is yes. Since it is possible to lift cars in this position and the standard requires in 5.7.4.3 a) and b):

"On vehicle lifts with carrying arms the rated load shall be distributed on the four corners of a rectangle with the dimensions of 100 cm (width) with the maximum load at the maximum length of the longest arm and the short arm in the position which gives the worst condition."

The manufacturer has to consider this position in the safety design of its vehicle lift.

VG 8 sees two basic approaches:

- prevention of lifting in such a position (for example, by limiting the swiveling range of the arms, a safety device prevents a lifting movement in this position or a load moment limiting device)
- sufficient stability and attachment of the vehicle lift, so that the rated load can be lifted safely also in this position

Calculation - permissible stresses

The normal values of permissible stresses are given in Annex A of EN 1493:2010. A safety factor of 1,5 must be achieved.

In view of the situation, that in this position usually only smaller vehicles can be lifted, which do not reach the rated load of the lift, it is acceptable in that case to reduce the safety factors for the calculation of stability and strength.

Under the most unfavorable loading conditions - all four arms on one side of the lift, long arms in maximum ejection position, pick up points in wheel track direction 1m distance, pick up points in wheelbase direction 1m distance, rated load according section 5.7.4.3 a) and b) at least a minimum safety factor of 1,2 is acceptable. The vehicle lift has to be sufficiently strong and stable during movement of the load.

In that case an additional warning label on the lift and a appropriate note in the user manual shall include the prohibition of the use in this position

In the position distance in wheelbase direction 1,4m (normative rectangle) a safety factor of 1,5 must be kept.

If the use of the lift in this way (four arms in one direction) is approved by the manufacturer, a reduction of lift capacity in this position by labelling is not allowed.

(1) Essential health and safety requirement

Note: According to point 6.6 of the Guide of the implementation of directives based on the New Approach and the Global Approach, the notified bodies apply as general guidance this recommendation for use.

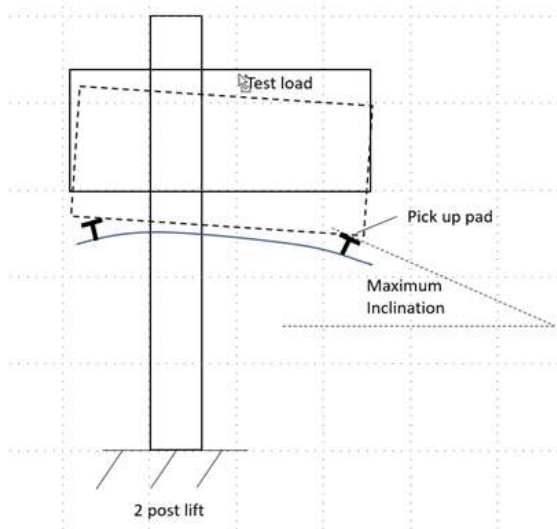
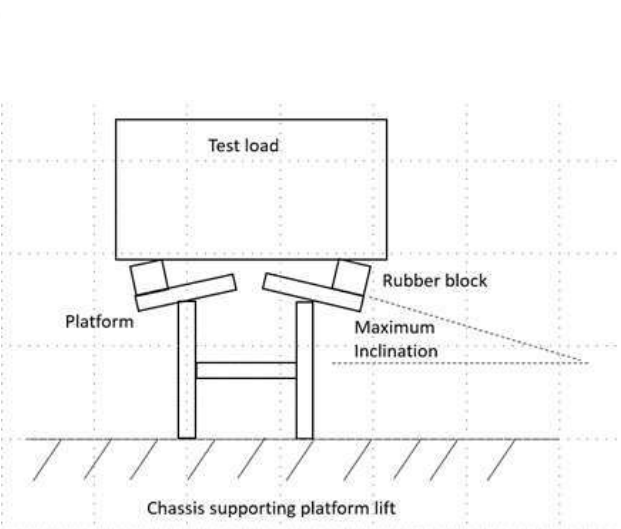
	CO-ORDINATION OF NOTIFIED BODIES Machinery Directive 2006/42/EC + amendments RECOMMENDATION FOR USE		CNB/M/08.023 Revision: 03 Language: EN
Number of pages: 1 Origin: VG8 Vehicles servicing lifts	Date: 03.07.2023	To be approved by: <input checked="" type="checkbox"/> Vertical Group <input checked="" type="checkbox"/> Horizontal Committee To be endorsed by: <input checked="" type="checkbox"/> Machinery Expert Group	Approved on: 08.06.2021 16.12.2021 Endorsed on: 23.03.2023
Question related to: Directive 2006/42/EC Annex: -	Article: - EHSR (1): -	EN/prEN: 1493:2010 Normative clause: 6.1.5.2 CEN TC concerned: -	Other: - Other clause: -
Key words: Maximum inclination of pickup plates and pads			
Question: What is the maximum acceptable inclination to horizontal for the surface of pick up pads or plates of chassis supporting vehicle servicing lifts during the load test according to section 6.1.5.4			
Solution: The maximum angle, measured with an instrument with an accuracy of at least +/- 0,5 degrees, shall be 5 degrees to horizontal. After removal of the test load, no permanent deformation must be visible. Test conditions. <ul style="list-style-type: none"> - Lift the test load with load supporting points in all positions which create maximum stress in any load bearing part. - Rated load as test load, distributed according to 5.7.4.3 - Raise load until fully supported on pick up pads or surfaces and maintain in position for one minute - Inclination to be measured whilst load remains on lift <div style="display: flex; justify-content: space-around; align-items: flex-end;"> <div data-bbox="239 1456 798 1982" style="text-align: center;">  <p>2 post lift</p> </div> <div data-bbox="813 1456 1436 1982" style="text-align: center;">  <p>Chassis supporting platform lift</p> </div> </div>			

(1) Essential health and safety requirement

Note: According to point 6.6 of the Guide of the implementation of directives based on the New Approach and the Global Approach, the notified bodies apply as general guidance this recommendation for use.

	CO-ORDINATION OF NOTIFIED BODIES Machinery Directive 2006/42/EC + amendments RECOMMENDATION FOR USE		CNB/M/08.024 Revision: 04 Language: EN
Number of pages: 1	Date: 03.07.2023	To be approved by:	Approved on:
Origin: VG8 Vehicles servicing lifts		<input checked="" type="checkbox"/> Vertical Group <input checked="" type="checkbox"/> Horizontal Committee To be endorsed by: <input checked="" type="checkbox"/> Machinery Expert Group	21.12.2021 14.06.2022 Endorsed on: 23.03.2023
Question related to: Directive 2006/42/EC	Article: -	EN/prEN: 1493:2010	Other: -
Annex: -	EHSR (1): -	Normative clause: 6.1.3 CEN TC concerned: -	Other clause: -
Key words: Welding examination			
Question: How should a Body Examiner validate conformity with EN 1493:2010 6.1.3 Manufacturing check c) welding has been performed according to the drawings and 2006/42/EC Annex I 1.2.3 Risk of break-up during operation and 4.1.2.3. Mechanical strength for lifting equipment.			
Solution: Mechanical drawings for equipment must include clear and comprehensive indication of the welding to be used for fabrication. This must include specification of welder qualifications, procedures, material and equipment to be used, either specifically on a drawing or as a general specification for manufacture The Notified Body Examiner must visually compare a representative sample of the welding on the equipment being examined with that specified in the drawing. Based on informal visual inspection, where the Notified Body examiner has reason to suspect that welding is not of good quality, they must request credible NDT reports on welds which concern them. After testing at 150% proof load, NB examiners must visually examine welds likely to have been subjected to higher stresses and check for evidence of deformation or cracking. Again, if the examiner has concerns, they must request credible NDT reports for selected welds.			

(1) Essential health and safety requirement

Note: According to point 6.6 of the Guide of the implementation of directives based on the New Approach and the Global Approach, the notified bodies apply as general guidance this recommendation for use.

	CO-ORDINATION OF NOTIFIED BODIES Machinery Directive 2006/42/EC + amendments RECOMMENDATION FOR USE		CNB/M/08.025 Revision: 03 Language: EN
Number of pages: 1 Origin: VG8 Vehicles servicing lifts	Date: 03.07.2023	To be approved by: <input checked="" type="checkbox"/> Vertical Group <input checked="" type="checkbox"/> Horizontal Committee To be endorsed by: <input checked="" type="checkbox"/> Machinery Expert Group	Approved on: 31.05.2022 14.06.2022 Endorsed on: 23.03.2023
Question related to: Directive 2006/42/EC Annex: -	Article: - EHSR (1): -	EN/prEN: 1493:2010 Normative clause: 6.1.2 CEN TC concerned: -	Other: - Other clause: -
Key words: Structural Calculations			
Question: How should a Notified Body Examiner validate conformity with EN 1493:2010 6.1.2 Design check. The documents shall give all necessary information to enable: f) the structural calculations to be checked; and 2006/42/EC Annex I 1.3.2. Risk of break-up during operation and 4.1.2.3. Mechanical strength for lifting equipment			
Solution: The Notified Body examiner shall check that: <ul style="list-style-type: none"> - structural calculations are available in the Technical File - the calculations have been carried out competently - the calculations demonstrate that all the relevant loadings mentioned in EN 1493:2010 5.7 Structural Design of the Load Supporting Structure have been considered - the calculations demonstrate that under worst case loading, no parts exceed the permissible stresses in EN 1493:2010 Annex A. 			

(1) Essential health and safety requirement

Note: According to point 6.6 of the Guide of the implementation of directives based on the New Approach and the Global Approach, the notified bodies apply as general guidance this recommendation for use.

	CO-ORDINATION OF NOTIFIED BODIES Machinery Directive 2006/42/EC + Amendment RECOMMENDATION FOR USE	CNB/M/09.206 Revision 04 Language: E
Date of first stage: 02/04/2003	To be approved by:	
Origin: VG9 Lifting persons device (LPD)	<input checked="" type="checkbox"/> Vertical Group <input checked="" type="checkbox"/> Horizontal Committee	Approved on: 13/04/2010 11/12/2003
		To be endorsed by: <input checked="" type="checkbox"/> Machinery Working Group....
Question related to: Directive 2006/42/EC	Article: 12 (3)	Other:
Annex: IX	ESR (1):	Other clause:
		CEN TC concerned:
Key words: Lifting Persons Device (LPD), Suspended Access Equipment, modular construction, certification		
Question: Is it possible to certify the modules of a Suspended Access Equipment separately, provided the limits of application and conditions of use are clearly laid down?		
<p>Solution:</p> <p>NO "Temporary Suspended Platforms" designed on a modular basis in order to allow actual installations to be easily configured according to the needs on site can only be certified as a complete machine. It's up to the negotiation between the applicant and the NB to define which configuration of the machine represents in the best way all possibilities and which is then subject of the type examination procedure. The manufacturers instructions, the examination of which is part of the EC type-examination, must contain in detail descriptions which modules can be combined and how that has to be done to allow different configurations. A positive passing of the EC type-examination then leads to <u>one</u> certificate of the tested configuration including all possible combinations, described in the instructions. A modification of a module/component or the addition of a new one requires information from the manufacturer to the NB having issued the certificate and which has to decide, whether this modification needs renewal of the certificate or not.</p> <p>The idea, to regard all modules/components as interchangeable equipment and certify them independently, was not taken as an appropriate method of certification for these wishes of manufacturers to be more flexible.</p> <p>Adaptation procedure: FORMAL ADAPTATION IN CONFORMITY WITH DIRECTIVE 2006/42/EC</p>		

(1) Essential safety requirement

Note: According to point 6.6 of the Guide of the implementation of directives based on the New Approach and the Global Approach, the notified bodies apply as general guidance this recommendation for use.

	<p>CO-ORDINATION OF NOTIFIED BODIES Machinery Directive 2006/42/EC + Amendment</p> <p>RECOMMENDATION FOR USE</p>	<p>CNB/M/09.207 Revision 10</p> <p>Language: E</p>
Date of first stage: 17/07/1998	To be approved by:	
Origin: VG9 Lifting persons device (LPD)	<input checked="" type="checkbox"/> Vertical Group <input checked="" type="checkbox"/> Horizontal Committee	<p>Approved on:</p> <p>13/04/2010 26/11/2009</p>
		<p>To be endorsed by:</p> <input checked="" type="checkbox"/> Machinery Working Group....
Question related to: Directive 2006/42/EC	Article:	EN/prEN: Other:
Annex: IV	ESR (1):	Other clause:
		CEN TC concerned:
Key words: Type-examination		
Question: What is the range of an EC type-examination for a machine, where the lifting of persons is not the primary function?		
<p>Solution:</p> <p>In the minutes of the 167 1st meeting of the Council (internal market) held on 1993-06-14 it is stated: “The Council and the Commission agree that the type examination of a device for the lifting of persons shall be limited to the lifting device itself and not to the complete machine which includes the lifting device.”</p> <p>VG9 understands this statement as follows:</p> <ul style="list-style-type: none"> • In the case of interchangeable equipment the handling is explained in the Commission document: “Interchangeable equipment for lifting persons and equipment used with machinery designed for lifting goods for the purpose of lifting persons” available on the EUROPA website: http://ec.europa.eu/enterprise/sectors/mechanical/documents/guidance/machinery/index_en.htm • In case of an integral part of a machine, besides the examination and tests of the lifting appliance itself the EC type-examination has to include also those functions, components or aspects of the whole machine, the operation or malfunction of which affect the safety of lifted persons. 		

(1) Essential safety requirement

Note: According to point 6.6 of the Guide of the implementation of directives based on the New Approach and the Global Approach, the notified bodies apply as general guidance this recommendation for use.

	CO-ORDINATION OF NOTIFIED BODIES Machinery Directive 2006/42/EC + Amendment RECOMMENDATION FOR USE	CNB/M/09.209 Revision 04 Language: E
Date of first stage: 02/04/2003	To be approved by:	
Origin: VG9 Lifting persons device (LPD)	<input checked="" type="checkbox"/> Vertical Group <input checked="" type="checkbox"/> Horizontal Committee	Approved on: 13/04/2010 11/12/2003
		To be endorsed by: <input checked="" type="checkbox"/> Machinery Working Group....
Question related to: Directive 2006/42/EC	Article:	EN/prEN:
Annex: VI	ESR (1):	Other:
		Clause:
		Other clause:
Key words: EC type-examination, work platform, loader crane		
Question: What is the scope of a EC type-examination of a work platform installed on the boom of a loader crane on a vehicle?		
Solution:		
<p>In this case the notified body shall check conformity <u>of the entire device</u> for lifting persons constituted by the work platform, the loader crane and the supporting chassis with the Essential Health and Safety Requirements (EHSRs) of the directive 2006/42/EC (in particular: resistance, stability, control of the placing of the stabilisers).</p> <p>If the platform is designed for use on several models of cranes the EC type-examination certificate shall list the models concerned. The certificate shall also state the models of supporting chassis on which the conformity of the Lifting Persons device has been checked.</p>		
Adaptation procedure: FORMAL ADAPTATION IN CONFORMITY WITH DIRECTIVE 2006/42/EC		

(1) Essential safety requirement

Note: According to point 6.6 of the Guide of the implementation of directives based on the New Approach and the Global Approach, the notified bodies apply as general guidance this recommendation for use.

	<p align="center">CO-ORDINATION OF NOTIFIED BODIES Machinery Directive 2006/42/EC + Amendment</p> <p align="center">RECOMMENDATION FOR USE</p>		<p>CNB/M/09.305 Revision 06</p> <p>Language: E</p>
Date of first stage: 06/03/1998	To be approved by:		Approved on:
Origin: VG9 Lifting persons device (LPD)	<input checked="" type="checkbox"/> Vertical Group		13/04/2010
	<input checked="" type="checkbox"/> Horizontal Committee		11/06/1998
Question related to: Directive 2006/42/EC Article: Annex: I ESR (1): 6.3.2		EN/prEN:EN 280:2001+A2:2008	Other:
		Clause: 5.6.1	Other clause:
		CEN TC concerned:	
Key words: Mobile Elevated Workplatform (MWE), levelling system			
Question: Is in addition to the levelling system (mechanical or hydraulic) a manual adjustment of the platform level acceptable, which may cause a platform level or more than 5° ?			
<p>Solution: Yes, provided that in a master-slave levelling system and in an independent hydraulic or mechanical levelling system a manual adjustment is speed limited to 0,5°/s.</p> <p>Adaptation procedure: FORMAL ADAPTATION IN CONFORMITY WITH DIRECTIVE 2006/42/EC</p>			

(1) Essential safety requirement

Note: According to point 6.6 of the Guide of the implementation of directives based on the New Approach and the Global Approach, the notified bodies apply as general guidance this recommendation for use.

	<p>CO-ORDINATION OF NOTIFIED BODIES Machinery Directive 2006/42/EC + Amendment</p> <p>RECOMMENDATION FOR USE</p>	<p>CNB/M/09.307 Revision 04</p> <p>Language: E</p>
Date of first stage: 28/04/1999	To be approved by:	Approved on:
Origin: VG9 Lifting persons device (LPD)	<input checked="" type="checkbox"/> Vertical Group <input checked="" type="checkbox"/> Horizontal Committee	<p>13/04/2010 24/05/2000</p> <p style="text-align: center;">To be endorsed by:</p> <input checked="" type="checkbox"/> Machinery Working Group....
<p>Question related to: Directive 2006/42/EC Article:</p> <p>Annex: I ESR (1): 6.3.1</p>	<p>EN/prEN:</p> <p>Clause:</p> <p>CEN TC concerned:</p>	<p>Other:</p> <p>Other clause:</p>
Key words: Lifting Persons Device, safety gear		
Question: Do lifting persons device with positive driving units need safety gears ?		
<p>Solution:</p> <p>It is a general rule, that uncontrolled movements of the load carrying unit of LPD due to wear or failure in the driving unit need to be avoided. Appropriate means are overspeed governed safety gears, rupture valves, lock valves, redundant drive units, safety nuts etc. Standards for LPD address these means. Design of a driving unit taking into account factors to increase the loads and forces to be taken by them is not regarded as appropriate measure against uncontrolled movement.</p> <p>Adaptation procedure: FORMAL ADAPTATION IN CONFORMITY WITH DIRECTIVE 2006/42/EC</p>		

(1) Essential safety requirement

Note: According to point 6.6 of the Guide of the implementation of directives based on the New Approach and the Global Approach, the notified bodies apply as general guidance this recommendation for use.

	CO-ORDINATION OF NOTIFIED BODIES Machinery Directive 2006/42/EC + Amendment RECOMMENDATION FOR USE	CNB/M/09.309 Revision 04 Language: E
Date of first stage: 28/04/1999	To be approved by:	Approved on:
Origin: VG9 Lifting persons device (LPD)	<input checked="" type="checkbox"/> Vertical Group <input checked="" type="checkbox"/> Horizontal Committee	13/04/2010 24/05/2000
	To be endorsed by: <input checked="" type="checkbox"/> Machinery Working Group....	Endorsed on: 09/04/2001
Question related to: Directive 2006/42/EC Annex: I, IV	Article: ESR (1): 1.1.2, 1.6.2, 6.3.2	EN/prEN:EN 280:2001+A2:2008 Clause: 5.6.3 CEN TC concerned:
Other: Other clause:		
Key words: Mobile Elevated Work Platform, MEWP, access, movable guard, abnormal use		
Question: Is it acceptable to use manually liftable bars returning into the safeguarding position by gravity as means as protection at the access to work platforms ?		
Solution: Yes. The possibility of deliberate fixing in the open position of protection means at the access to work platforms needs not to be regarded as abnormal use which has to be prevented by construction.		
<h3 style="margin: 0;">Adaptation procedure: FORMAL ADAPTATION IN CONFORMITY WITH DIRECTIVE 2006/42/EC</h3>		

(1) Essential safety requirement

Note: According to point 6.6 of the Guide of the implementation of directives based on the New Approach and the Global Approach, the notified bodies apply as general guidance this recommendation for use.

	CO-ORDINATION OF NOTIFIED BODIES Machinery Directive 2006/42/EC + Amendment RECOMMENDATION FOR USE	CNB/M/09.310 Revision 05 Language: E
Date of first stage: 28/04/1999	To be approved by:	
Origin: VG9 Lifting persons device (LPD)	<input checked="" type="checkbox"/> Vertical Group <input checked="" type="checkbox"/> Horizontal Committee	Approved on: 13/04/2010 24/05/2000
		To be endorsed by: <input checked="" type="checkbox"/> Machinery Working Group....
Question related to: Directive 2006/42/EC	Article:	EN/prEN:
Annex: I	ESR (1): 4.1.2.4, 6.1.2	Other:
		Clause:
		Other clause:
		CEN TC concerned:
Key words: Man rider winches, one rope suspension		
Question: Is it acceptable to use one-rope suspension in person lifting device?		
<p>Solution:</p> <p>At silo access equipment and man rider winches doubled suspension elements create hazards which are not acceptable, e. g. twisting, entanglement, etc. Therefore on these equipment one-rope suspension is acceptable provided</p> <ol style="list-style-type: none"> 1. steel wire ropes with at least 10mm diameter are used in order to have a certain resistance against mechanical damage, 2. the factor of utilisation is at least 10, 3. the design of the rope drive is in accordance with prEN 280:1998, Annex C, with the load collective "heavy", 4. there are protective means preventing derailing of the rope from the drum or any pulley, 5. the winding up on the drum is governed by a spooling device, 6. there is a slack-rope device 7. the rope is suitably protected against corrosion and other environmental influences and 8. the instructions for use are clearly stating <ul style="list-style-type: none"> • the need of periodical inspections of the device • the need of inspection of the rope before starting work where the winch was not used for a longer period of time taking into account the provisions laid down in the EU-Directive 2009/104/EC and environmental conditions and • criteria for the replacement of the rope. <p>These provisions do not cover all aspects of these kind of LPD. Other aspects have to be subject of a risk assessment in accordance with the Machinery Directive.</p> <p>Adaptation procedure: FORMAL ADAPTATION IN CONFORMITY WITH DIRECTIVE 2006/42/EC</p>		

(1) Essential safety requirement

Note: According to point 6.6 of the Guide of the implementation of directives based on the New Approach and the Global Approach, the notified bodies apply as general guidance this recommendation for use.

	CO-ORDINATION OF NOTIFIED BODIES Machinery Directive 2006/42/EC + amendments RECOMMENDATION FOR USE		CNB/M/09.318 Revision: 07 Language: EN
Number of pages: 2 Origin: VG9 Lifting persons device (LPD)	Date: 03.07.2023	To be approved by: <input checked="" type="checkbox"/> Vertical Group <input checked="" type="checkbox"/> Horizontal Committee To be endorsed by: <input checked="" type="checkbox"/> Machinery Expert Group	Approved on: 12.06.2015 29.06.2016 Endorsed on: 23.03.2023
Question related to: Directive 2006/42/EC Annex: I	Article: - EHSR (1): -	EN/prEN: - Normative clause: - CEN TC concerned: -	Other: - Other clause: -
Key words: crushing hazards, ram frame.			
Question: Which specific requirements apply for service lifts used in wind turbines?			
Solution: <p>Scope and definition: A wind turbine is a machine in the scope of the directive 2006/42/EC because it contains moving parts fitted with a drive system (rotating of the yaw-system and/or rotor blades). When the wind turbine is equipped with a lift, the lifting equipment, including the landings and suspension, are subject to annex IV.17. A lift in a wind turbine is not only used for accessing the landings but also for other purposes like maintenance and inspections.</p> <p>Communication system: As a minimum, in view of its use in remote locations, a two way communication system has to be prescribed during normal use as well as during emergency operations.</p> <p>Carrier: Due to the lack of operating space (crushing and shearing hazards may occur when there is no opening distance of minimal 0.5 m is feasible) and for the protection against falling objects, usually a full enclosure of the carrier is necessary.</p> <p>The carrier must be equipped with an emergency stop.</p> <p>Opening carrier door(s) between landings: According to the requirements of Directive 2006/42/EG chapter 6.4.1 „...The door(s) must remain closed when the carrier stops between landings and where there is a risk of falling from the carrier...“, the opening of the carrier door(s) between the landings is not permitted and therefore a guard locking device preventing the opening of the door(s) until the carrier reaches a landing, is necessary.</p> <p>The carrier door must be equipped with a device which prevents movement of the carrier in case the door is in an open position.</p> <p>In practice, stopping between landings and opening of the carrier door may be required for purposes like maintenance. In that case, the following requirements exist:</p> <ul style="list-style-type: none"> • as soon as the carrier door is opened (by operating an additional separate handling device which is not used during normal operation of the lift and unlocks the carrier door lock) travelling of the carrier shall be stopped as long as the carrier door is open. This mechanism must not be easily accessible and be provided with a marking • when the carrier door is opened, prevention of falling of persons out of the carrier is required and leaving and entering are not allowed excluding during rescue operations. <p>In view of the use in remote locations, the opening of the carrier door for rescue operations shall be possible from both the in- and outside of the carrier.</p>			

Solution continued:

Protection of persons in the travel zone:

Crushing and shearing hazards are relevant when the distance between carrier and the rescue ladder is $\leq 0,5\text{m}$. When there is the possibility of hazardous contact between the moving carrier and persons on the ladder and at the landing gates, safeguarding at the floor and roof of the carrier must be present. The performance level shall be according to EN ISO 13849-1. Following the path S2-F1-P2, the result will be PL=d.

If the distance between carrier and the rescue ladder is more than 0.5 m, the safeguards can be used to protect the persons at the landings. When the full height landing gate is changed into a reduced height landing gate with minimum height of 1.1 m, the performance level shall be according to EN ISO 13849-1. Following the path S2-F1-P1 the result will be PL=c.

Landings and landing gates:

Landings are places for entering or leaving the carrier. This can be at the top or the bottom and at intermediate stops of the travel zone.

If the distance between the carrier and the landing gate is smaller than 0.5 m, a full height landing gate is required to prevent shearing and crushing hazards. If the distance between the carrier and the landing gate is smaller than 0.5 m, a reduced height landing gate (minimum height 1.1m) is allowed if the carrier is safeguarded at the top and bottom and has a flat surface. In this case, the performance level shall be according to EN ISO 13849-1. Following the path S2-F1-P1 the result will be PL=c.

The distance from the landing gates to the landing sill must be $\leq 0.15\text{ m}$ or else a safety device which detect and protect persons/obstacles must be present.

Interlocking of landing gates:

The risk assessment for the landing gates must cover the intended access to the carrier as well as the intended access to a ladder (e. g. for rescue operations):

- The landing door can be opened by a primary mechanism (bar/catch) if the carrier is present. The landing door cannot be opened by primary mechanism when the carrier is absent. The position of the carrier at the landing shall be detected making sure the carrier is in the correct travel zone for the opening of the door(s).
- The landing door can be opened when, in case of a rescue operation, the operator wants to use the ladder by operating an additional mechanism – e. g. second bar – which is not used during normal operating the lift; this feature shall be considered in the risk assessment. This additional opening mechanism is only necessary for opening the landing door when the carrier is not present at the landing. This mechanism may not to be easily accessible and be provided with a marking

Rescue conception:

The manufacturer of lifting equipment for the use by persons within wind turbines shall ensure that a contingency plan for rescue is available. The following points shall be considered:

- the person that has to be rescued is not able to assist during rescue (e.g. unconscious),
- adequate anchoring devices for the rescue teams in and on the carrier - EN 795,
- changing positions from the carrier to the ladder shall be possible in a safe way,
- ergonomic solutions shall be preferred,
- a carrier shall have a device for lowering the carrier in case of emergency.

(1) Essential health and safety requirement

Note: According to point 6.6 of the Guide of the implementation of directives based on the New Approach and the Global Approach, the notified bodies apply as general guidance this recommendation for use.

	CO-ORDINATION OF NOTIFIED BODIES Machinery Directive 2006/42/EC + Amendment RECOMMENDATION FOR USE	CNB/M/09.401 Revision 08 Language: E
Date of first stage: 02/04/2003	To be approved by:	
Origin: VG9 Lifting persons device (LPD)	<input checked="" type="checkbox"/> Vertical Group <input checked="" type="checkbox"/> Horizontal Committee	Approved on: 13/04/2010 11/12/2003
		To be endorsed by: <input checked="" type="checkbox"/> Machinery Working Group....
Question related to: Directive 2006/42/EC	Article:	EN/prEN:EN 280:2001+A2:2008 Other:
Annex: I	ESR (1): 1.2.4	Clause: 5.7.5 Other clause:
GEN TC concerned: TC 98 WG 1		
Key words: MEWP, control devices, emergency stop, override		
Question: Is it allowed that a MEWP is equipped with a control at the base or ground level, which functions as an override for the emergency stop control situated on the work platform for the reason of rescuing of injured or incapacitated operators?		
<p>Solution:</p> <p>CEN/TC 98/WG 1 has studied the situation in its meeting 05.96. It was felt, that the trapping of a person in the work platform can happen due to different reasons, e.g. plucking out the energy supply, actuating the emergency control device, etc. The result in these cases is an unpleasant or awkward situation but not a direct risk to the persons. Therefore a need to override the emergency stop device at the control panel cannot be seen. The standard EN 280:2001+A2:2008 states in its foreword that it is assumed that persons on the work platform in case of power supply failure are not incapacitated and can assist in the operation of the overriding emergency device.</p> <p>Nevertheless there may be situations where the operator is incapacitated and the platform emergency stop pressed. In this situation the overriding emergency device may be too slow to recover the operator from the ground especially for high MEWPs. Therefore the need of an overriding cannot be ignored. Any overriding of the emergency stop control at the work platform of a MEWP shall require a deliberate action on a device being a safety device, independent from the selection control device and protected against unauthorised use.</p> <p>Emergency stop overriding shall not be possible on MEWPs which are equipped with a mode selection device acc. to Machinery Directive 2006/42/EC Annex I section 1.2.5 to bypass safety functions.</p> <p>Adaptation procedure: FORMAL ADAPTATION IN CONFORMITY WITH DIRECTIVE 2006/42/EC</p>		

(1) Essential safety requirement

Note: According to point 6.6 of the Guide of the implementation of directives based on the New Approach and the Global Approach, the notified bodies apply as general guidance this recommendation for use.

	<p style="text-align: center;">CO-ORDINATION OF NOTIFIED BODIES Machinery Directive 2006/42/EC + Amendment</p> <p style="text-align: center;">RECOMMENDATION FOR USE</p>	<p>CNB/M/09.501 Revision 05</p> <p>Language: E</p>
<p>Date of first stage: 28/04/1999</p>	<p>To be approved by:</p>	<p>Approved on:</p>
<p>Origin: VG9 Lifting persons device (LPD)</p>	<p><input checked="" type="checkbox"/> Vertical Group</p> <p><input checked="" type="checkbox"/> Horizontal Committee</p> <p>To be endorsed by:</p> <p><input checked="" type="checkbox"/> Machinery Working Group....</p>	<p>13/04/2010</p> <p>24/05/2000</p> <p>Endorsed on:</p> <p>09/04/2001</p>
<p>Question related to: Directive 2006/42/EC Article: Annex: I ESR (1): 1.5.10, 1.5.11</p>	<p>EN/prEN: Clause: CEN TC concerned:</p>	<p>Other: Other clause:</p>
<p>Key words: Radiation, EC-type examination, EMC directive</p>		
<p>Question: Does EMC directive cover all aspects of radiation addressed in 1.5.10 and 1.5.11 of Annex I Machinery directive?</p>		
<p>Solution:</p> <p>The provisions of the EMC-Directive do not cover all aspects of radiation addressed in 1.5.10 and 1.5.11.</p> <p>Especially regarding immunity of controls of LPD the following aspects need to be taken into consideration during type-examination:</p> <ol style="list-style-type: none"> 1. Light barriers shall not be influenced by light from the environment (sun, artificial light), 2. UV-radiation has influence on components made of plastic, 3. Laser beams can be dangerous for persons in the environment of the machine, 4. Sensors used as warning devices related to distances may be made inoperable, 5. Radio controls used in the environment may cause uncontrolled movements, 6. Ionised radiation may occur in case of fire, 7. Intended radiation like from mobile phones may cause malfunctions. <p>see also data sheet CNB/M/00.502</p> <p>Adaptation procedure: FORMAL ADAPTATION IN CONFORMITY WITH DIRECTIVE 2006/42/EC</p>		

(1) Essential safety requirement

Note: According to point 6.6 of the Guide of the implementation of directives based on the New Approach and the Global Approach, the notified bodies apply as general guidance this recommendation for use.

	CO-ORDINATION OF NOTIFIED BODIES Machinery Directive 2006/42/EC + amendments RECOMMENDATION FOR USE		CNB/M/09.502 Revision: 02 Language: EN
Number of pages: 1	Date: 03.07.2023	To be approved by:	Approved on:
Origin: VG9 Lifting persons device (LPD)		<input checked="" type="checkbox"/> Vertical Group	01.06.2015
		<input checked="" type="checkbox"/> Horizontal Committee	29.06.2016
		To be endorsed by:	Endorsed on:
		<input checked="" type="checkbox"/> Machinery Expert Group	23.03.2023
Question related to: Directive 2006/42/EC	Article: -	EN/prEN: a) EN 1808	Other: -
Annex: II	EHSR (1): 1.3.2 Risk of break-up in operation 6.1.1 Mechanical Strength	Normative clause: -	Other clause: -
CEN TC concerned: a) CEN/TC 98 Lifting platforms			
Key words: lifting platforms, lifts, gripping device/safety gear, tripping device / overspeed governor, safety device, lifting persons			
<p>Question:</p> <p>Safety devices in machinery for lifting persons can consist of components which may be affected by wear. For example a safety gear triggered by an overspeed governor. When wear of a component can lead to a complete loss of functioning of the safety device, extra measures are necessary. The manufacturers usually specify a safe life period for these components.</p> <p>The relevant standard for this type of machine (EN1808:2015) has no additional requirements for testing and evaluation of safety relevant components affected by wear. Also this standard demands no determination of a lifetime of safety relevant components in the case these components are affected by wear.</p> <p>Is it necessary to verify during a type examination the prescribed life time by the manufacture and what are the conditions?</p>			
<p>Solution:</p> <p>The claimed lifetime of all safety components that are affected by wear needs to be verified during a type examination.</p> <p>Basis for the verification is the $B_{0,01d}$ value of the tested components which needs to be higher than the prescribed overhaul/lifetime by the manufacturer.</p> <p>The $B_{0,01d}$ value is based on the B_{10d} value used by EN ISO 13849-1:2015.</p> <p>The $B_{0,01d}$ value can be determined by calculation and verified by testing.</p>			

(1) Essential health and safety requirement

Note: According to point 6.6 of the Guide of the implementation of directives based on the New Approach and the Global Approach, the notified bodies apply as general guidance this recommendation for use.

 <p>EUROPEAN CO-ORDINATION MACHINERY OF NOTIFIED BODIES</p>	<p>CO-ORDINATION OF NOTIFIED BODIES Machinery Directive 2006/42/EC + Amendment</p> <p>RECOMMENDATION FOR USE</p>	<p>CNB/M/11.017 Revision 05</p> <p>Language: E</p>
Date of first stage: 10/04/1997	To be approved by:	
Origin: VG11 Safety components	<input checked="" type="checkbox"/> Vertical Group <input checked="" type="checkbox"/> Horizontal Committee	<p>Approved on:</p> <p>25/10/2010 11/06/1998</p>
<p>Question related to: Directive 2006/42/EC Article:</p> <p>Annex: IX ESR (1):</p>		<p>EN/prEN:</p> <p>Clause:</p> <p>CEN TC concerned:</p>
Key words: EC type-examination, pre-standards		
<p>Question:</p> <p>Should in case of EC type-examination European pre-standards (prEN) be used rather than national standards?</p>		
<p>Solution:</p> <p>Yes, the European pre-standards should be used if they represent much more the state of the art. It stands to reason that the procedure is accepted by the manufacturer.</p> <p>Adaptation procedure: FORMAL ADAPTATION IN CONFORMITY WITH DIRECTIVE 2006/42/EC</p>		

(1) Essential safety requirement

Note: According to point 6.6 of the Guide of the implementation of directives based on the New Approach and the Global Approach, the notified bodies apply as general guidance this recommendation for use.

	CO-ORDINATION OF NOTIFIED BODIES Machinery Directive 2006/42/EC + Amendment RECOMMENDATION FOR USE	CNB/M/11.027 Revision 08 Language: E
Date of first stage: 10/04/1997	To be approved by:	Approved on:
Origin: VG11 Safety components	<input checked="" type="checkbox"/> Vertical Group <input checked="" type="checkbox"/> Horizontal Committee	25/10/2010 14/12/2010
	To be endorsed by:	Endorsed on:
	<input checked="" type="checkbox"/> Machinery Working Group....	23/05/2011
Question related to: Directive 2006/42/EC	Article:	EN/prEN: EN 574:1996
Annex: IV-21	ESR (1):	Other:
		Clause: 5.7.1.
		Other clause:
	GEM TC concerned: TC 114	
Key words: two-hand control devices, synchronous actuation		
Question:		
<p>For type III two-hand control devices, EN 574 requires synchronous actuation of both buttons in order to prevent defeating. This means that both buttons have to be actuated within a defined time range not larger than 0.5 sec.</p> <p>EN 574 allows time ranges smaller than 0.5 sec, but if the time range is too short, the operator has to concentrate highly on the synchronous actuation of the two buttons. From ergonomic aspects, this is bad. What is the minimum value of the time range?</p>		
Solution:		
<p>The requirement given in the Machinery Directive, Annex I, 1.1.6. "Under the intended conditions of use, the discomfort, fatigue and physical and psychological stress faced by the operator must be reduced to the minimum possible, taking into account ergonomic principles..." has to be observed.</p> <p>The Technical Committee responsible for EN 574 will be asked to specify a minimum value for the time range. In the meantime, for ergonomic reasons, a minimum value of 0.25 sec should be used.</p>		

(1) Essential safety requirement

Note: According to point 6.6 of the Guide of the implementation of directives based on the New Approach and the Global Approach, the notified bodies apply as general guidance this recommendation for use.

	CO-ORDINATION OF NOTIFIED BODIES Machinery Directive 2006/42/EC + Amendment RECOMMENDATION FOR USE	CNB/M/11.031 Revision 09 Language: E
Date of first stage: 01/11/2001	To be approved by:	Approved on:
Origin: VG11 Safety components	<input checked="" type="checkbox"/> Vertical Group <input checked="" type="checkbox"/> Horizontal Committee To be endorsed by: <input checked="" type="checkbox"/> Machinery Working Group....	25/10/2010 14/12/2010 Endorsed on: 23/05/2011
Question related to: Directive 2006/42/EC Article: Annex: IV-19 ESR (1):	EN/prEN: EN 61496-1/A2/Ed. 2/ CDV:2010 Clause: 4.2.2.3. CENELEC TC concerned: TC 44X	Other: Other clause:
Key words: ESPE Type 2 with PLC as means of periodic test		
<p>Question:</p> <p>A Type 2 ESPE (Electro-Sensitive Protective Equipment) consists of an assembly of a sensing device, a controlling/monitoring device and one or more Output Signal Switching Device(s) (OSSDs), which shall perform a test to reveal a failure to danger at power-on of the ESPE before going to the ON-state and at each reset as a minimum.</p> <p>This assembly can be implemented in one device, they can also be separated in two devices. In the latter case the testing and monitoring functionality can be performed in a non-safety-related PLC by software while the ESPE safety function is processed independently of the non-safety-related PLC.</p> <p>For the sensing device in combination with the controlling/monitoring device and the OSSD(s) an EC type-examination certificate can be issued.</p> <p>Is it permissible to issue an EC type-examination certificate for a sensing device intended to be combined with any customary non-safety-related PLC as a safety component according to Annex IV, 19 (Type 2 ESPE)?</p>		
<p>Solution:</p> <p>Yes, the periodic tests of the safety function during operation may be implemented in a non-safety-related PLC, if the following requirements are met:</p> <ul style="list-style-type: none"> • the testing is dynamic i.e. both high and low states are checked during the testing; • the software is as a known module protected from manipulation by the end user; • the standard PLC meets the environmental requirements of EN 61496-1 for a Type 2 ESPE; and • the instructions describe in detail: <ul style="list-style-type: none"> - the different elements which constitute the ESPE; - how the sensing device has to be connected with the PLC; and - how the fixed software module has to be implemented in the user program <p>An EC type-examination shall be carried out on this safety component consisting of the sensing device with an OSSD(s), the fixed software module, and a designated PLC with a Secondary Switching Device (SSD).</p> <p>The owner of the certificate is considered as the manufacturer of the ESPE.</p> <p>Depending on the application, the periodic test may need to be performed more often than described in the first part of the question above to achieve a desired safety performance.</p>		

(1) Essential safety requirement

Note: According to point 6.6 of the Guide of the implementation of directives based on the New Approach and the Global Approach, the notified bodies apply as general guidance this recommendation for use.

	CO-ORDINATION OF NOTIFIED BODIES Machinery Directive 2006/42/EC + Amendment RECOMMENDATION FOR USE	CNB/M/11.032 Revision 05 Language: E
Date of first stage: 24/09/2002	To be approved by:	Approved on:
Origin: VG11 Safety components	<input checked="" type="checkbox"/> Vertical Group <input checked="" type="checkbox"/> Horizontal Committee To be endorsed by: <input checked="" type="checkbox"/> Machinery Working Group....	25/10/2010 03/03/2004 Endorsed on: 24/12/2004
Question related to: Directive 2006/42/EC Article: Annex: IV-19 ESR (1):	EN/prEN: EN 61496-1:2004 + A1:2008 Clause: 4.2.5, A 5.4, A 6.4, A 7.4 CENELEC TC concerned: TC 44X	Other: Other clause:
Key words: Arrangement of visual indicators		
<p>Question:</p> <p>EN 61496-1:2004+A1:2008 demands that ESPE (a) have visual indicators for the OSSD (b) status (red/green) and for the start/restart interlock status (yellow). There is no specification about the location where these visual indicators are to be arranged</p> <p>Where shall these visual indicators be arranged?</p> <p>Abbreviations:</p> <p>(a) ESPE: Electro-sensitive protective Equipment</p> <p>(b) OSSD: Output Switching Signal Device</p>		
<p>Solution:</p> <p>All visual indicators shall provide sufficient information for the machine operator.</p> <p>For this reason the visual indicators for start / restart condition, mute status and blanking shall be arranged in such a way that they are readily visible from any position of the operator during normal operation of the machine for which the ESPE (a) is intended as a safeguard. Indicators for the actuation of the sensing device and output status of the OSSDs (b) are intended for installation and maintenance and for that reason do not need to be visible from all positions by the operator.</p> <p>(a) ESPE: Electro-sensitive protective Equipment</p> <p>(b) OSSDs: Output Switching Signal Devices</p>		
<h2>Adaptation procedure: FORMAL ADAPTATION IN CONFORMITY WITH DIRECTIVE 2006/42/EC</h2>		

(1) Essential safety requirement

Note: According to point 6.6 of the Guide of the implementation of directives based on the New Approach and the Global Approach, the notified bodies apply as general guidance this recommendation for use.

	CO-ORDINATION OF NOTIFIED BODIES Machinery Directive 2006/42/EC + amendments RECOMMENDATION FOR USE		CNB/M/11.033 Revision: 09 Language: EN
Number of pages: 1	Date: 03.07.2023	To be approved by:	Approved on:
Origin: VG11 Safety components		<input checked="" type="checkbox"/> Vertical Group <input checked="" type="checkbox"/> Horizontal Committee To be endorsed by: <input checked="" type="checkbox"/> Machinery Expert Group	22.05.2019 16.12.2021 Endorsed on: 23.03.2023
Question related to: Directive 2006/42/EC	Article: -	EN/prEN: EN 574 and EN ISO 13851	Other: -
Annex: IV - 21	EHSR (1): 1.2.1.	Normative clause: -	Other clause: -
Key words: -			
Question: When shall a single fault be detected when using a type III C two-hand control according to EN 574:1996+A1:2008 and/or EN ISO 13851:2019?			
Solution: In a type III C two-hand control device, a single fault shall be detected and lead to a safe state as soon as possible, but latest when a change of state of the output signal is requested (e. g. by releasing one or both of the control actuating devices). Note: It is state of the art for this application that mechanical faults of push buttons are excluded when the push-buttons are in accordance with EN 60947-5-1.			

(1) Essential health and safety requirement

Note: According to point 6.6 of the Guide of the implementation of directives based on the New Approach and the Global Approach, the notified bodies apply as general guidance this recommendation for use.

	CO-ORDINATION OF NOTIFIED BODIES Machinery Directive 2006/42/EC + Amendment RECOMMENDATION FOR USE	CNB/M/11.035 Revision 08 Language: E
Date of first stage: 24/09/2002	To be approved by:	Approved on:
Origin: VG11 Safety components	<input checked="" type="checkbox"/> Vertical Group <input checked="" type="checkbox"/> Horizontal Committee To be endorsed by: <input checked="" type="checkbox"/> Machinery Working Group....	25/10/2010 14/12/2010 Endorsed on: 23/05/2011
Question related to: Directive 2006/42/EC Article: Annex: IV-19 ESR (1):	EN/prEN: EN 61496:2004 + A1:2008 Clause: A.7 CEN TC concerned:	Other: Other clause:
Key words: Indication of a muted ESPE, colour of the mute indicator(s) of an ESPE		
<p>Question: EN 61496-1, Annex A.7 (Muting) requires an indication of the muted state of an ESPE (Electro-Sensitive Protective Equipment), but does not specify a colour. What colour should be used?</p> <p>Note 1: In the old prEN 50100-1 (clause 4.2.4) the colour of the indication of the muted condition of the ESPE was required to be white. Table 2 of EN 61310-1 requires yellow for warnings, but yellow could conflict with the indication of the start or restart interlock. According to ANSI B11.19 an amber light is recommended to be used to indicate that the safeguard is muted or bypassed.</p>		
<p>Solution: Both colours yellow or white may be used if there is no conflict with other indicators e. g. interlock. Note 2: EN 61496-1:2004+A1:2008, 4.2.5 requires: When there are two or more indicators of the same colour the function of each indicator shall be unambiguously marked.</p>		

(1) Essential safety requirement

Note: According to point 6.6 of the Guide of the implementation of directives based on the New Approach and the Global Approach, the notified bodies apply as general guidance this recommendation for use.

	<p style="text-align: center;">CO-ORDINATION OF NOTIFIED BODIES Machinery Directive 2006/42/EC + Amendment RECOMMENDATION FOR USE</p>		<p>CNB/M/11.036 Revision 07 Language: E</p>
Date of first stage: 28/09/2004	To be approved by:		Approved on:
Origin: VG11 Safety components	<input checked="" type="checkbox"/> Vertical Group <input checked="" type="checkbox"/> Horizontal Committee		25/10/2010 14/12/2010
		To be endorsed by:	Endorsed on:
Question related to: Directive 2006/42/EC Article:		EN/prEN:	Other:
Annex: IV-19	ESR (1):	Clause:	Other clause:
Key words: laser scanner, industrial truck			
<p>Question:</p> <p>In narrow alleys of stocks persons may be injured by an industrial truck in case of collision between the industrial truck and a person. To prevent such accidents, laser scanners are used to detect persons and initiate a stop of the industrial truck.</p> <p>What are the conditions for laser scanners to be used in this application?</p>			
<p>Solution:</p> <p>Laser scanners (AOPDDRs) intended to be used for such applications shall fulfil the requirements of EN 61496-1 and CLC/TS 61496-3. As a minimum the additions and modifications listed below are to be observed. It is necessary to distinguish between those applications where:</p> <ul style="list-style-type: none"> • access of persons is generally allowed; and • access of persons is forbidden at the time the industrial truck is operated. <p>Therefore the following list contains general requirements and specific requirements for the two different applications (see annex).</p>			

(1) Essential safety requirement

Note: According to point 6.6 of the Guide of the implementation of directives based on the New Approach and the Global Approach, the notified bodies apply as general guidance this recommendation for use.

1. General requirements

1.1 Detection zone dimensions

- a) The length of the detection zone shall be calculated taking into account the maximum speed of the industrial truck, the response times of the protective equipment, the machine control etc. and the maximum braking distance. An addition of 10 % as a minimum should be made to consider a decrease of the brakes.
- b) The width of the detection zone shall be such to enable the detection of the test piece defined in 1.2. It has to be taken into account that the tracking of an industrial truck always will have tolerances. For example, a tracking tolerance of 15 mm can lead to a change of the detection zones outer corner position in operation of some 10 mm. Without any user advice this can lead to problems concerning safety in terms of a decreased or not existing detection capability and on the other hand to an unacceptable low reliability in operation.

1.2 Test piece dimension

The test piece used for analysis and test shall be cylindrical with dimensions as indicated in figure 1. In most cases the detection capability will be affected by a test piece with minimum diffuse reflectivity.

Note: CLS/TS 61496-3 defines a minimum diffuse reflectivity of 1.8 % in the range of wavelength that is within the scope.

1.3 Detection capability

The detection of the test piece within the detection zone shall be guaranteed by test according to CLS/TS 61496-3. At the left and right outer border line of the detection zone the test piece shall be detected when placed with its centre in a distances of 125 mm from an empty rack. The maximum tracking tolerance as defined by the manufacturer of the protective device shall be taken into account.

1.4 Start interlock and restart interlock

Start interlock and restart interlock are required in operation when it is not guaranteed that a person is detected at any position in front of an industrial truck.

1.5 Accompanying documents

The accompanying documents shall inform the user on how to calculate the dimensions of the detection zone by example. The width of the detection zone is required to be given as a distance from the empty rack. The maximum tracking tolerance of the industrial truck together with other limiting information shall be given.

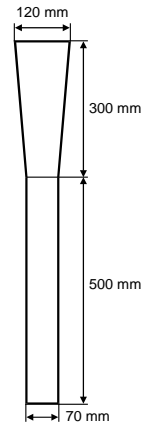

Figure 1: Test piece dimensions

2. Application where access is allowed

2.1 Type

Laser scanners intended to be used for this application shall fulfil the requirements for type 3 as defined in CLS/TS 61496-3.

2.2 Mounting

The mounting height of a laser scanner shall be as such as to enable the detection of the test piece defined in 1.2 and in addition of a person lying on the floor. To simulate this within a test, a second test piece with a diameter of 200 mm and a length of 1.000 mm shall be used.

3. Application where access is forbidden

3.1 Type

Laser scanners intended to be used for this application shall fulfil the requirements for type 3 as defined in CLS/TS 61496-3. Alternatively the fault detection requirements fulfilled by a type 2 device according to EN 61496-1 are sufficient due to the lower risk compared to the application where access is allowed.

3.2 Mounting

The mounting height of a laser scanner shall be such as to enable the detection of the test piece defined in 1.2.

3.3 Extra regulation

If the requirement to detect the test piece at the left and right outer border line of the detection zone given in 1.3 cannot be fulfilled taking into account the tracking tolerance of the industrial truck, the following extra regulation for application where access is forbidden can be applied.

- a) At the left and right outer border line of the detection zone the test piece shall be detected when placed with its centre in a distance of 125 mm from an empty rack. The tracking tolerance is not taken into account.
- b) The test piece position is varied from its original position (centre 125 mm from empty rack). For every 10 mm additional distance the length of the detection zone shall be increased by 200 mm.
- c) The maximum distance between the test piece centre and the empty rack is limited to 200 mm which leads to an increase of the detection zone of 1.500 mm.

	CO-ORDINATION OF NOTIFIED BODIES Machinery Directive 2006/42/EC + Amendment RECOMMENDATION FOR USE		CNB/M/11.047 Revision 03 Language: E
	Date of first stage: 11/05/2010	To be approved by:	Approved on:
Origin: VG11 Safety components	<input checked="" type="checkbox"/> Vertical Group <input checked="" type="checkbox"/> Horizontal Committee	11/05/2010 15/06/2010	
	To be endorsed by: <input checked="" type="checkbox"/> Machinery Working Group....	Endorsed on: 30/12/2010	
Question related to: Directive 2006/42/EC Article: Annex: I ESR (1): 1.2.1	EN/prEN: EN ISO 13849-1 / EN 62061 Clause: CEN TC concerned:	Other: Other clause:	
Key words: Using parts with wear-out in safety components			
Question: How do parts with wear-out such as relays have to be taken into account when estimating the PFH _d (a) of a safety component? Abbreviation: (a) PFH _d : Probability of dangerous Failure per Hour			
Solution: The PL or SIL of a safety component depends on the PFH _d (a). It is not sufficient however to specify PFH _d (a) as the sole safety parameter without stating the conditions under which this value is valid. Standards such as EN ISO 13849-1 or EN 62061 use the concept of B10 _d when calculating probability of failures. This concept takes into account e.g. the average number of operations per time unit and the load conditions. Note: Information on procedures to determine B10 _d values are given e.g. in EN 60947-4-1 for contactors or in IEC 61810-2-1 for electromechanical elementary relays and ISO 19973-1, -2 for pneumatic components. Typical values for B10 _d can be found in EN ISO 13849-1, Annex C. VG11 replaced the term "PFH" by "PFH _d " and added the note on 26/10/2010.			

(1) Essential safety requirement

Note: According to point 6.6 of the Guide of the implementation of directives based on the New Approach and the Global Approach, the notified bodies apply as general guidance this recommendation for use.

	CO-ORDINATION OF NOTIFIED BODIES Machinery Directive 2006/42/EC + Amendment RECOMMENDATION FOR USE	CNB/M/11.049 Revision 03 Language: E
Date of first stage: 25/10/2010	To be approved by:	
Origin: VG11 Safety components	<input checked="" type="checkbox"/> Vertical Group <input checked="" type="checkbox"/> Horizontal Committee	Approved on: 25/10/2010 14/12/2010
	To be endorsed by: <input checked="" type="checkbox"/> Machinery Working Group....	Endorsed on: 23/05/2011
Question related to: Directive 2006/42/EC Article: Annex: IV-21 ESR (1):	EN/prEN: Clause: CEN TC concerned:	Other: Other clause:
Key words: logic units to ensure safety functions / Environmental conditions		
Question: Logic units to ensure safety functions shall be tested in environmental conditions (climatic, electrical, EMC, vibrations, bump, etc.). For the time being, there is no general standard for the detailed requirements. How can the test laboratory determine these requirements?		
Solution: There is no general standard for logic units and the requirements depend highly on the application, the technology used, and the expected environmental conditions. Therefore, it is the task of the Notified Body to determine the appropriate requirements.		

(1) Essential safety requirement

Note: According to point 6.6 of the Guide of the implementation of directives based on the New Approach and the Global Approach, the notified bodies apply as general guidance this recommendation for use.

	CO-ORDINATION OF NOTIFIED BODIES Machinery Directive 2006/42/EC + Amendment RECOMMENDATION FOR USE	CNB/M/11.050 Revision 05 Language: E
Date of first stage: 18/10/2011	To be approved by:	Approved on:
Origin: VG11 Safety components	<input checked="" type="checkbox"/> Vertical Group <input checked="" type="checkbox"/> Horizontal Committee To be endorsed by: <input checked="" type="checkbox"/> Machinery Working Group....	06/06/2013 26/06/2013 Endorsed on: 22/11/2013
Question related to: Directive 2006/42/EC Article: Annex: IV – 19, 20, 21 and Annex I ESR (1): 1.2.1	EN/prEN: Clause: CEN TC concerned:	Other: Other clause:
Key words: Failure, electromechanical outputs		
Question: What are the minimum requirements concerning the frequency of tests for failure detection in a safety-related system with 2 channels with electromechanical outputs (relays or contactors)?		
Solution: A functional test (automatic or manual) to detect failures shall be performed within the following test intervals: a) at least every month for PL e with Category 3 or Category 4 (according to EN ISO 13849-1) or SIL 3 with HFT (hardware fault tolerance) = 1 (according to EN 62061); b) at least every 12 months for PL d with Category 3 (according to EN ISO 13849-1) or SIL 2 with HFT (hardware fault tolerance) = 1 (according to EN 62061). NOTE: It is recommended that the functional test is initiated by the control system of the machine. If this is not possible, then it is recommended that the control system of the machine reminds the user (e.g. by an appropriate indication at the control panel) to perform a functional test of the safety function. If this is also not possible, an appropriate requirement has to be contained in the instructions for use.		

(1) Essential safety requirement

Note: According to point 6.6 of the Guide of the implementation of directives based on the New Approach and the Global Approach, the notified bodies apply as general guidance this recommendation for use.

	CO-ORDINATION OF NOTIFIED BODIES Machinery Directive 2006/42/EC + Amendment RECOMMENDATION FOR USE	CNB/M/11.052 Revision 02 Language: E
Date of first stage: 18/10/2011	To be approved by:	Approved on:
Origin: VG11 Safety components	<input checked="" type="checkbox"/> Vertical Group <input checked="" type="checkbox"/> Horizontal Committee To be endorsed by: <input checked="" type="checkbox"/> Machinery Working Group....	18.10.2011 13/12/2011 Endorsed on: 23/04/2012
Question related to: Directive 2006/42/EC Article: 2 (c) Annex: ESR (1):	EN/prEN: Clause: CEN TC concerned:	Other: Other clause:
Key words: Safety components, safety functions		
Question: Some devices (e.g. an industrial remote control) incorporate non-safety related functions and one or more safety functions. Are such devices to be considered as safety components in the sense of the Machinery Directive?		
Solution: Yes. As soon as a device serves to fulfil a safety function, it is considered as safety component in the sense of the Machinery Directive, provided that the other conditions according to Article 2 (c) of the Machinery Directive are met. The safety-related part has to fulfil the essential requirements of the Machinery Directive. During conformity assessment, the non-safety-related parts also have to be considered to ensure that they have no negative influence on the safety-related part.		

(1) Essential safety requirement

Note: According to point 6.6 of the Guide of the implementation of directives based on the New Approach and the Global Approach, the notified bodies apply as general guidance this recommendation for use.

	CO-ORDINATION OF NOTIFIED BODIES Machinery Directive 2006/42/EC + Amendment RECOMMENDATION FOR USE	CNB/M/11.053 Revision 03 Language: E
Date of first stage: 10/05/2012	To be approved by:	
Origin: VG11 Safety components	<input checked="" type="checkbox"/> Vertical Group <input checked="" type="checkbox"/> Horizontal Committee	Approved on: 10/05/2012 28/06/2012
		To be endorsed by: <input checked="" type="checkbox"/> Machinery Working Group....
Question related to: Directive 2006/42/EC	Article:	EN/prEN: EN ISO 13849-1:2008 Other:
Annex: I	ESR (1): 1.2.1	Clause: 5.2.2. Other clause:
GEM TC concerned: TC 114		
Key words: Manual reset function		
Question: For the manual reset function in logic units to ensure safety functions, EN ISO 13849-1, subclause 5.2.2, 6th indent, requires the change of the state of the reset button from pressed to released. In some logic units to ensure safety functions the manual reset function was designed to react to the change of the state of the reset button from released to pressed, as was required in EN 954-1, subclause 5.4. Do these logic units comply with the requirements of the Machinery directive?		
Solution: Yes. In this case, the technical file has to contain a statement that the product does not fully comply with the 6th indent of subclause 5.2.2 of EN ISO 13849-1. The manufacturer of the logic unit has to show that the manual reset function has an appropriate Performance Level. The same level of safety provided by the technical solution in the 6th indent of subclause 5.2.2 of EN ISO 13849-1 can be achieved by other technical solutions.		

(1) Essential safety requirement

Note: According to point 6.6 of the Guide of the implementation of directives based on the New Approach and the Global Approach, the notified bodies apply as general guidance this recommendation for use.

	<p style="text-align: center;">CO-ORDINATION OF NOTIFIED BODIES Machinery Directive 2006/42/EC + Amendment</p> <p style="text-align: center;">RECOMMENDATION FOR USE</p>	CNB/M/11.054 Revision 03 Language: E						
Date of first stage: 06/06/2013	To be approved by: <table style="width: 100%; border: none;"> <tr> <td style="width: 70%;"> <input checked="" type="checkbox"/> Vertical Group <input checked="" type="checkbox"/> Horizontal Committee </td> <td style="width: 30%; vertical-align: top;"> Approved on: 06/06/2013 26/06/2013 </td> </tr> <tr> <td colspan="2" style="text-align: center; padding: 5px 0;">To be endorsed by:</td> </tr> <tr> <td> <input checked="" type="checkbox"/> Machinery Working Group.... </td> <td style="vertical-align: top;"> Endorsed on: 22/11/2013 </td> </tr> </table>		<input checked="" type="checkbox"/> Vertical Group <input checked="" type="checkbox"/> Horizontal Committee	Approved on: 06/06/2013 26/06/2013	To be endorsed by:		<input checked="" type="checkbox"/> Machinery Working Group....	Endorsed on: 22/11/2013
<input checked="" type="checkbox"/> Vertical Group <input checked="" type="checkbox"/> Horizontal Committee	Approved on: 06/06/2013 26/06/2013							
To be endorsed by:								
<input checked="" type="checkbox"/> Machinery Working Group....	Endorsed on: 22/11/2013							
Origin: VG11 Safety components								
Question related to: Directive 2006/42/EC Article: Annex: I ESR (1): 1.7.4.	EN/prEN: Clause: CEN TC concerned:	Other: Other clause:						
Key words: Safety components, instructions								
Question: Which parts of the instructions for use have to be provided in paper form?								
Solution: Two levels have to be distinguished: 1) In the case of safety components where tools (PC, tablets etc. with or without internet access) are necessary for the integration of the safety component, health and safety relevant information can be supplied partly in paper form (quick-start-guide) and partly in electronic form. The quick-start-guide has to contain as a minimum the following: <ul style="list-style-type: none"> - identification of the safety component to which it belongs, - information on connections and interfaces, - information on the intended use, - information on the reasonably foreseeable misuse, - conditions and limitations for use, - information, where the complete instructions for use can be found. 2) In the case of safety components where such tools are not needed, health and safety relevant information has to be supplied in paper form.								

(1) Essential safety requirement

Note: According to point 6.6 of the Guide of the implementation of directives based on the New Approach and the Global Approach, the notified bodies apply as general guidance this recommendation for use.

	CO-ORDINATION OF NOTIFIED BODIES Machinery Directive 2006/42/EC + Amendment RECOMMENDATION FOR USE	CNB/M/11.055 Revision 04 Language: E
Date of first stage: 07/06/2013	To be approved by:	Approved on:
Origin: VG11 Safety components	<input checked="" type="checkbox"/> Vertical Group	02/06/2014
	<input checked="" type="checkbox"/> Horizontal Committee	17/06/2014
Question related to: Directive 2006/42/EC Article: 2 (c) Annex: I ESR (1): 1.5.1.	EN/prEN:	Other:
	Clause:	Other clause:
	CEN TC concerned:	
Key words: Cogeneration plants, combined heat and power plants (CHP), grid monitoring		
Question: Is the grid monitoring device of a cogeneration plant considered a safety component in the sense of Article 2 (c) of the Machinery Directive, if it is placed on the market independently?		
Solution: Yes. If a local installation with cogeneration plant is disconnected from the electrical power grid, the cogeneration plant could still feed energy into the local installation. This situation is hazardous because some persons might think there is no electrical hazard due to the disconnection from the electrical power grid. In these cases, grid monitoring devices are used to - disconnect the cogeneration plant from the local installation, and - in some cases - - shut down the generator and prevent start-up. Grid monitoring devices therefore serve to reduce a risk coming from cogeneration plants and are consequently considered a safety component in the sense of Article 2 (c) of the Machinery Directive and furthermore as a logic unit for safety functions in the sense of Annex IV, item 21.		

(1) Essential safety requirement

Note: According to point 6.6 of the Guide of the implementation of directives based on the New Approach and the Global Approach, the notified bodies apply as general guidance this recommendation for use.

	CO-ORDINATION OF NOTIFIED BODIES Machinery Directive 2006/42/EC + Amendment RECOMMENDATION FOR USE	CNB/M/11.056 Revision 03 Language: E
Date of first stage: 07/06/2013	To be approved by:	Approved on:
Origin: VG11 Safety components	<input checked="" type="checkbox"/> Vertical Group <input checked="" type="checkbox"/> Horizontal Committee	07/06/2013 26/06/2013
	To be endorsed by:	Endorsed on:
	<input checked="" type="checkbox"/> Machinery Working Group....	22/11/2013
Question related to: Directive 2006/42/EC	Article:	EN/prEN: EN
Annex: I	ESR (1): 1.2.1.	Other:
	Clause: 5.7	Other clause:
	CEN TC concerned: TC 114	
Key words: Two-hand control devices, synchronous actuation, operating conditions		
Question:		
EN 574:1996+A1:2008 requires in its subclause 5.7 a synchronous actuation of both actuators in a period of time less than or equal to 0.5 s.		
Is it necessary that this maximum synchronisation time is observed also under variation of operating conditions such as the supply voltage?		
Solution:		
Yes. The maximum synchronisation time is a safety feature and shall therefore not be exceeded under the operating conditions stated by the manufacturer.		
NOTE: Generally, all safety functions have to work correctly under the operating conditions stated by the manufacturer and by standards.		

(1) Essential safety requirement

Note: According to point 6.6 of the Guide of the implementation of directives based on the New Approach and the Global Approach, the notified bodies apply as general guidance this recommendation for use.

	CO-ORDINATION OF NOTIFIED BODIES Machinery Directive 2006/42/EC + Amendment RECOMMENDATION FOR USE	CNB/M/11.058 Revision 03 Language: E
Date of first stage: 07/06/2013	To be approved by:	Approved on:
Origin: VG11 Safety components	<input checked="" type="checkbox"/> Vertical Group	07/06/2013
	<input checked="" type="checkbox"/> Horizontal Committee	26/06/2013
Question related to: Directive 2006/42/EC Article: 2(c) Annex: ESR (1):	To be endorsed by:	Endorsed on:
	<input checked="" type="checkbox"/> Machinery Working Group....	22/11/2013
	EN/prEN: Other: Clause: Other clause: CEN TC concerned:	
Key words: Safety component, warning device		
Question: Is a warning device that requires the action of the operator to achieve a safe state considered a safety component in the sense of Article 2 (c) of the Machinery Directive?		
Solution: No. However, the device can be assessed according to functional safety standards used for safety components.		

(1) Essential safety requirement

Note: According to point 6.6 of the Guide of the implementation of directives based on the New Approach and the Global Approach, the notified bodies apply as general guidance this recommendation for use.

	CO-ORDINATION OF NOTIFIED BODIES Machinery Directive 2006/42/EC + Amendment RECOMMENDATION FOR USE	CNB/M/11.059 Revision 03 Language: E								
Date of first stage: 03/06/2014	To be approved by:	Approved on:								
Origin: VG11 Safety components	<input checked="" type="checkbox"/> Vertical Group <input checked="" type="checkbox"/> Horizontal Committee To be endorsed by: <input checked="" type="checkbox"/> Machinery Working Group....	03/06/2014 17/06/2014 Endorsed on: 08/01/2015								
Question related to: Directive 2006/42/EC Article: Annex: IV - 19 / 20 / 21 ESR (1):	EN/prEN: EN 61508 Clause: CEN TC concerned: CLC/TC 65X	Other: Other clause:								
Key words: Diagnostic functions, EN 61508:2010										
Question: How shall failures in diagnostic functions in single-channel structures (HFT = 0) be analysed and evaluated if EN 61508:2010 is used?										
Solution: <p>Failures in diagnostic functions that can directly introduce a failure in the safety function / element safety function should be handled like failures in the safety function / element safety function itself.</p> <p>For diagnostic functions that cause a critical state related to the safety function / element safety function in a two or more fault scenario one of the following approaches shall be applied:</p> <ol style="list-style-type: none"> The diagnostic functions are considered as separate functions and shall fulfill the requirements as shown in the table below. <table border="1" data-bbox="247 1384 778 1556"> <thead> <tr> <th>Safety function</th> <th>Diagnostic function</th> </tr> </thead> <tbody> <tr> <td>SIL 1</td> <td>Basic safety principles</td> </tr> <tr> <td>SIL 2</td> <td>SIL 1</td> </tr> <tr> <td>SIL 3</td> <td>SIL 2</td> </tr> </tbody> </table> A failure in a diagnostic function that increases the probability that the safety function does not operate correctly when required, shall be classified as dangerous failure according to IEC 61508-4:2010, clause 3.6.7. A failure in a diagnostic function that leads directly to the safe state shall be classified as safe failure according to IEC 61508-4:2010, clause 3.6.8. <p>Note: For diagnostic functions monitoring only other diagnostics functions, no safety requirements have to be applied.</p>			Safety function	Diagnostic function	SIL 1	Basic safety principles	SIL 2	SIL 1	SIL 3	SIL 2
Safety function	Diagnostic function									
SIL 1	Basic safety principles									
SIL 2	SIL 1									
SIL 3	SIL 2									

(1) Essential safety requirement

Note: According to point 6.6 of the Guide of the implementation of directives based on the New Approach and the Global Approach, the notified bodies apply as general guidance this recommendation for use.

	CO-ORDINATION OF NOTIFIED BODIES Machinery Directive 2006/42/EC + amendments RECOMMENDATION FOR USE		CNB/M/11.060 Revision: 06 Language: EN
Number of pages: 1 Origin: VG11 Safety components	Date: 03.07.2023	To be approved by: <input checked="" type="checkbox"/> Vertical Group <input checked="" type="checkbox"/> Horizontal Committee To be endorsed by: <input checked="" type="checkbox"/> Machinery Expert Group	Approved on: 22.05.2019 16.12.2021 Endorsed on: 23.03.2023
Question related to: Directive 2006/42/EC Annex: IV - 19 / 20 / 21	Article: - EHSR (1): 1.2.1.	EN/prEN: - Normative clause: - CEN TC concerned: -	Other: - Other clause: -
Key words: External DC power supply of safety component, PELV, abnormal voltage			
Question: What abnormal supply voltage of an external DC power supply has to be considered for a safety component intended to be supplied with PELV (protective extra low voltage)?			
Solution: For supply voltages up to 60 V DC, the safety component has to remain in a safe state. NOTE: EN 60204-1:2018 as well as EN 60204-1:2006, require that PELV does not exceed 60 V DC, even in case of a failure.			

(1) Essential health and safety requirement

Note: According to point 6.6 of the Guide of the implementation of directives based on the New Approach and the Global Approach, the notified bodies apply as general guidance this recommendation for use.

	CO-ORDINATION OF NOTIFIED BODIES Machinery Directive 2006/42/EC + Amendment RECOMMENDATION FOR USE	CNB/M/11.061 Revision 06 Language: E
Date of first stage: 03/06/2014	To be approved by:	
Origin: VG11 Safety components	<input checked="" type="checkbox"/> Vertical Group <input checked="" type="checkbox"/> Horizontal Committee	Approved on: 02/06/2015 29/06/2016
		To be endorsed by: <input checked="" type="checkbox"/> Machinery Working Group....
Question related to: Directive 2006/42/EC Article: Annex: IV - 21 ESR (1):	EN/prEN:	Other:
	Clause:	Other clause:
Key words: RFID-based protective devices		
Question: Protective devices for indirect detection of the presence of persons, for example by the use of RFID (radio-frequency identification) technology, are considered to be a logic unit to ensure safety functions as described by CNB/M/11.045. In applications such as baling presses where material is transported via a conveyor belt into the press, such RFID-based protective devices have been used successfully as a protective measure in the past. However, no standard exists that deals with such systems. Are there general requirements or a general standard to take into account for an EC type-examination of a RFID-based protective device?		
Solution: Since RFID-based protective devices are used in the same environment as electro-sensitive protective equipment (ESPE), the standard that describes the general requirements and tests for ESPE (EN 61496-1) shall be applied also in case of a RFID-based protective device. In the process of an EC type-examination also technology specific aspects shall be covered. The most important task in this case is to verify that the integrity of the detection capability of a RFID-based protective device is maintained: <ul style="list-style-type: none"> - independent of the orientation of the tag; - independent from coverage of the tag by the human body; - independent from coverage of the tag by process material such as plastics, composite material or metal foils; - in presence of several (different) tags; - when using more than one RFID-based protective device. Organizational measures have to focus on periodically scheduled checks and that all personnel exposed to the relevant risks is equipped with transponder tags. These organizational measures have to be covered by the instructions for use.		

(1) Essential safety requirement

Note: According to point 6.6 of the Guide of the implementation of directives based on the New Approach and the Global Approach, the notified bodies apply as general guidance this recommendation for use.

	CO-ORDINATION OF NOTIFIED BODIES Machinery Directive 2006/42/EC + Amendment RECOMMENDATION FOR USE	CNB/M/11.062 Revision 04 Language: E
Date of first stage: 09/06/2015	To be approved by:	Approved on:
Origin: VG11 Safety components	<input checked="" type="checkbox"/> Vertical Group <input checked="" type="checkbox"/> Horizontal Committee To be endorsed by: <input checked="" type="checkbox"/> Machinery Working Group....	09/06/2015 02/12/2015 Endorsed on: 23/09/2016
Question related to: Directive 2006/42/EC Article: 2 c) Annex: IV - 19 ESR (1):	EN/prEN: EN ISO 13856 series Clause: GEN TC concerned:	Other: Other clause:
Key words: pressure-sensitive protective device, sensor, control unit, OSSDs, definition		
Question: What is a pressure-sensitive mat (or edge or buffer)?		
Solution: According to the definitions in the EN ISO 13856 series, a pressure-sensitive protective device consists of a sensor, a control unit and OSSDs (output signal switching devices). Therefore, a sensor alone (although commonly referred to as mat, edge or buffer) is not a safety component in the sense of the Machinery Directive. Example: According to EN ISO 13856-1, 3.1, the definition of pressure-sensitive mat reads: "Sensitive protective equipment (ISO 12100:2010, 3.28.5) comprising a sensor (3.3) or sensors, a control unit (3.5) and one or more one or more output signal switching devices (3.6) which detects a person standing on it or who steps onto it and where the effective sensing area (3.4) is deformed locally when the sensor(s) is actuated." So in the EN ISO 13856 series, the term "mat" (or "edge" or "buffer") is not used for the sensor, but for the combination of sensor, control unit and OSSDs.		

(1) Essential safety requirement

Note: According to point 6.6 of the Guide of the implementation of directives based on the New Approach and the Global Approach, the notified bodies apply as general guidance this recommendation for use.

	CO-ORDINATION OF NOTIFIED BODIES Machinery Directive 2006/42/EC + Amendment		CNB/M/11.065 Revision 03 Language: E
Date of first stage: 01/06/2017	To be approved by:		Approved on:
Origin: VG11 Safety components	<input checked="" type="checkbox"/> Vertical Group <input checked="" type="checkbox"/> Horizontal Committee To be endorsed by: <input checked="" type="checkbox"/> Machinery Working Group.		01/06/2017 07/06/2017 Endorsed on: 31/01/2018
Question related to: Directive 2006/42/EC	Article:	EN/prEN: EN 61496-2:2013	Other:
Annex: IV - 19	ESR (1):	Clause: 4.2.2.4 IEC TC concerned: TC 44 / MT 61496-2	Other clause:
Key words: AOPD, type			
<p>Question: EN 61496-2:2013 does not define requirements for an AOPD Type 3. Nevertheless, such devices can be found on the market. Should these Type 3 devices fulfil the special requirements of Type 2 or for Type 4 as long as the standard does not give such information?</p> <p>Solution:</p> <p>As long as EN 61496-2 does not define a Type 3 AOPD such devices shall fulfil the requirements and its related test procedures of the following:</p> <ul style="list-style-type: none"> • EN 61496-1 Type 3; • EN 61496-2 general requirements; and • EN 61496-2 Type 4 requirements given in the following subclauses: <ul style="list-style-type: none"> - 4.1.2.2.2 (Sensing function); - 4.2.12 (Integrity of the AOPD detection capability); - 4.3.5 (Light interference); and - A.11.3 (Functional requirements for a type 4 AOPD), if applicable. <p>Note: Subclause numbers are related to EN 61496-2:2013</p>			

(1) Essential safety requirement

Note: According to point 6.6 of the Guide of the implementation of directives based on the New Approach and the Global Approach, the notified bodies apply as general guidance this recommendation for use.

	CO-ORDINATION OF NOTIFIED BODIES Machinery Directive 2006/42/EC + amendments RECOMMENDATION FOR USE		CNB/M/11.067 Revision: 03 Language: EN
Number of pages: 1 Origin: VG11 Safety Components	Date: 03.07.2023	To be approved by: <input checked="" type="checkbox"/> Vertical Group <input checked="" type="checkbox"/> Horizontal Committee To be endorsed by: <input checked="" type="checkbox"/> Machinery Expert Group ...	Approved on: 22.01.2021 16.12.2021 Endorsed on: 23.03.2023
Question related to: Directive 2006/42/EC Annex: IV – 19, 20 and 21	Article: 2 safety components and logic unit EHSR (1): -	EN/prEN: IEC 62061 and ISO 13849-1 Validation activities Normative clause: - CEN TC concerned: -	Other: - Other clause: -
Key words: Testing, witness testing, remote testing of safety components and logic unit Validation criteria in line with ANNEX II (of the Guide to application of the Machinery Directive 2006/42/EC Edition 2.2 – October 2019) §418 Table of safety components which are considered to be logic units.			
Question: What are the rules of Procedure covering validation and testing, remote testing or witnessing testing for logic unit / safety component manufacturer's and for mandatory EC type examination certification.			
Solution: For items covered by items 19, 20 and 21 of annex IV 2006/42/EC machinery directive, notified bodies are certifying the associated safety component and logic units by several means that are mainly validation by analysis, validation by simulation and validation by tests. Remote validation and remote testing activities are possible but they remain in all cases under the responsibility of the notified body to accept or not. The following list is not an exhaustive list Validation by analysis covers: <ul style="list-style-type: none"> • Definition of the safety function • Validation by analysis of the compliance of the safety component / logic unit to the criteria of harmonized standards, standards and other technical specifications (qualitative and quantitative requirements of the standards - e.g. SIL/SIL CL for IEC 62061, category, PL, MTTFD, ... of ISO 13849-1) and safety analysis methods e.g. FMECA, Markov, ... • Other mandatory requirements of the machinery directive (instructions, EC declaration of conformity, technical file, marking, ...) Validation by simulation Validation by tests covers: <ul style="list-style-type: none"> • Functional test of the product to verify the characteristics of the safety function (e.g. response time, ...) • Environmental tests (mechanical tests-vibrations and shocks, EMC tests, temperature tests, ...) • Fault tests injections. 			

(1) Essential health and safety requirement

Note: According to point 6.6 of the Guide of the implementation of directives based on the New Approach and the Global Approach, the notified bodies apply as general guidance this recommendation for use.

	CO-ORDINATION OF NOTIFIED BODIES Machinery Directive 2006/42/EC + amendments RECOMMENDATION FOR USE		CNB/M/11.068 Revision: 02 Language: EN
Number of pages: 1 Origin: VG11 Safety Components	Date: 03.07.2023	To be approved by: <input checked="" type="checkbox"/> Vertical Group <input checked="" type="checkbox"/> Horizontal Committee To be endorsed by: <input checked="" type="checkbox"/> Machinery Expert Group	Approved on: 22.01.2021 16.12.2021 Endorsed on: 23.03.2023
Question related to: Directive 2006/42/EC Annex: IV – 19	Article: - EHSR (1): -	EN/prEN: EN IEC 61496-3:2019 Normative clause: - CEN TC concerned: -	Other: - Other clause: -
Key words: AOPDDR, IP protection class			
Question: Should a Notified Body issue an EC type examination certificate for an AOPDDR (e.g. laser scanner) if the manufacturer describes that the AOPDDR enclosure is opened on delivery and therefore does not meet the IP 65 degree of protection specified in EN IEC 61496-3:2019, 4.3.4?			
Solution: No. EN IEC 61496-3:2019 does not set any requirements to evaluate pollution of internal optical components. This is justified by the assumption that the required IP protection class is not maintained only in short term in rare cases, such as the replacement of an optical window or a connector. Delivery of an AOPDDR with an open enclosure contradicts the objective to maintain the detection capability.			

(1) Essential health and safety requirement

Note: According to point 6.6 of the Guide of the implementation of directives based on the New Approach and the Global Approach, the notified bodies apply as general guidance this recommendation for use.

	CO-ORDINATION OF NOTIFIED BODIES Machinery Directive 2006/42/EC + amendments RECOMMENDATION FOR USE		CNB/M/11.069 Revision: 02 Language: EN
Number of pages: 1 Origin: VG11 Safety components	Date: 03.07.2023	To be approved by: <input checked="" type="checkbox"/> Vertical Group <input checked="" type="checkbox"/> Horizontal Committee To be endorsed by: <input checked="" type="checkbox"/> Machinery Expert Group	Approved on: 14.09.2021 16.12.2021 Endorsed on: 23.03.2023
Question related to: Directive 2006/42/EC Annex: -	Article: - EHSR (1): -	EN/prEN: EN 60204-1:2018 Normative clause: 9.1.1 CEN TC concerned: TC 44X	Other: - Other clause: -
Key words: Transformers			
<p>Question:</p> <p>Clause 9.1.1 in EN 60204-1:2018 contains following exception for the requirement for transformers:</p> <p style="padding-left: 40px;">Exception: Transformers or switch mode power supply units fitted with transformers are not mandatory for machines with a single motor starter and/or a maximum of two control devices (for example, interlock device, start/stop control station).</p> <p>In an elder version of this standard (EN 60204-1:1998) the sentence was clearer:</p> <p style="padding-left: 40px;">Transformers are not mandatory for machines with a single motor starter and a maximum of two control devices (e.g. interlock device, start/stop control station).</p> <p>The use of "and" means that both conditions (only one motor starter, maximum of two control devices) need to be met to apply the exception ("transformers are not mandatory").</p> <p>The meaning of "and/or" is, that complying with either the first or the second or both conditions is necessary to apply the exception. This was most likely not the intention of the rule-setter.</p>			
<p>Solution:</p> <p>A corrigendum to the standard seems appropriate and the respective TC will be informed. In order to close the time gap until the publication of a correction, this RfU is intended to contribute to clarification.</p> <p>The exception should read:</p> <p style="padding-left: 40px;">Exception: Transformers or switch mode power supply units fitted with transformers are not mandatory for machines with not more than one motor starter and a maximum of two control devices (for example, interlock device, start/stop control station).</p>			

(1) Essential health and safety requirement

Note: According to point 6.6 of the Guide of the implementation of directives based on the New Approach and the Global Approach, the notified bodies apply as general guidance this recommendation for use.

	CO-ORDINATION OF NOTIFIED BODIES Machinery Directive 2006/42/EC + Amendment RECOMMENDATION FOR USE	CNB/M/12.009 Revision 05 Language: E
Date of first stage: 07/05/1996	To be approved by:	Approved on:
Origin: VG 12 ROPS and FOPS	<input checked="" type="checkbox"/> Vertical Group	21/11/2013
	<input checked="" type="checkbox"/> Horizontal Committee	10/12/2013
Question related to: Directive 2006/42/EC Annex: I	Article:	Other:
	ESR (1): 3.4.3., 3.4.4.	Other clause:
	EN/prEN:	Other:
Key words: Minor modification	Clause:	Other clause:
	CEN TC concerned:	
Question: What kind of modifications of ROPS and FOPS can be accepted without new test?		
Solution: Safety cabs will be modified during the course of their production life. In order to make it simpler for all involved modifications to a tested safety cab may be made without requiring a retest. <ol style="list-style-type: none"> 1) Change of model denomination as a result of production processing, e.g. painting, trimming are not structural and therefore consideration to test mass used for a ROPS test may be the only additional information needed for model changes. 2) The drilling of holes for wiring or painting process and the addition for brackets for mounting of mirrors, lights, etc. needs consideration to given to the size an location and whether they would affect the test result. 3) Changes of seats resulting in new positions for SIP (seat index point), changes to the design or size of structural members including the addition of gussets, changes which affect the clearance between DLV (deflection-limiting volume) and safety cab or ground line changes of mounting brackets are beyond the understanding of minor modifications. This does not mean that they can not be considered. However as a notified body you must be confident that in the event of a fatal accident you can produce evidence that any modifications approved offer the same protection as the original design. It is also important to keep in mind that comparison tests between say different mounts is not the total affect on the original test, as the safety cab and mounts work as an unit. With these points in mind may we suggest that modifications of this nature are very hard to substantiate. <p>The additional data sheet of the original certificate must contain:</p> <ul style="list-style-type: none"> - a reference to the original certificate - a reference to the original test report - a unique number for this modifications - a description of the changes made including references to drawings and issue numbers - declaration of acceptance - the date of approval and – if applicable – limited series numbers 		

(1) Essential safety requirement

Note: According to point 6.6 of the Guide of the implementation of directives based on the New Approach and the Global Approach, the notified bodies apply as general guidance this recommendation for use.

	CO-ORDINATION OF NOTIFIED BODIES Machinery Directive 2006/42/EC + Amendment RECOMMENDATION FOR USE	CNB/M/12.012 Revision 07 Language: E
Date of first stage: 27/10/2000	To be approved by:	Approved on:
Origin: VG 12 ROPS and FOPS	<input checked="" type="checkbox"/> Vertical Group <input checked="" type="checkbox"/> Horizontal Committee	21/11/2013 10/12/2013
	To be endorsed by:	Endorsed on:
Key words: ROPS		
Question: According to clause 6.1.4 of EN ISO 3471:2008 the load device shall not impede rotation of the ROPS. If two cylinders are used on a four-post ROPS, the test can be complete fail if the ROPS is allowed to rotate freely. How shall the the lateral and vertical load test be performed on test facilities with two loading cylinders?		
Solution: The requirement of clause 6.1.4 of EN ISO 3471:2008 is to be intended such that "load distribution device" does not constrain rotations of the structure. The use of one or two cylinders for loading is a matter of technical arrangement to fulfil the requirement laid down in clause 6.2.6 and 6.2.7 i.e. load application point displacement and force applied must be recorded in a "deformation controlled" loading sequence. ROPS structure rotation shall not be hindered but the loading device shall not induce rotation. The combination of the requirements suggest that in a two-cylinder loading machine, displacement of both cylinders must be controlled in order to meet the "deformation control" required by clause 6.2.6 and 6.2.7. The effective load application point resulting of the forces of the two cylinders shall always be within the boundary planes of the DLV (deflection-limiting volume).		

(1) Essential safety requirement

Note: According to point 6.6 of the Guide of the implementation of directives based on the New Approach and the Global Approach, the notified bodies apply as general guidance this recommendation for use.

	CO-ORDINATION OF NOTIFIED BODIES Machinery Directive 2006/42/EC + Amendment RECOMMENDATION FOR USE		CNB/M/13.000 Revision 03 Language: EN
Date of first stage: 21/08/2008	To be approved by:		Approved on:
Origin: VG13 Full quality assurance	<input checked="" type="checkbox"/> Vertical Group..... <input checked="" type="checkbox"/> Horizontal Committee..... To be endorsed by: <input checked="" type="checkbox"/> Machinery Working Group..		21/08/2008 09/12/2008 Endorsed on: 18/06/2009
Question related to: 2006/42/EC Annex: X	Article: EHSR (1):	EN/prEN: Normative clause: CEN TC concerned:	Other: Other clause:
Key words: equivalence to Annex IX			
Question: Do Annex IX and Annex X conformity assessment procedures lead to equivalent results, namely safe and compliant machines?			
Recommended solution: Yes. The outcome of Annex IX and Annex X conformity assessment procedures should be equivalent, namely safe and compliant machines. The focus of Annex IX is the type examination of a sample of the product by the Notified Body while for Annex X the focus of the Notified Body lies on the processes of design and manufacturing of the machinery. In both cases the manufacturer has responsibilities which can only be spot-checked by the Notified Body knowing that the outcome of both modules is considered equivalent.			

(1) Essential health and safety requirement

Note: According to point 6.6 of the Guide of the implementation of directives based on the New Approach and the Global Approach, the notified bodies apply as general guidance this recommendation for use.

 <p>MACHINERY</p>	<p>CO-ORDINATION OF NOTIFIED BODIES Machinery Directive 2006/42/EC + Amendment</p> <p>RECOMMENDATION FOR USE</p>	<p>CNB/M/13.001 Revision 04</p> <p>Language: E</p>
<p>Date of first stage: 21/01/2008</p>	<p>To be approved by:</p>	<p>Approved on:</p>
<p>Origin: VG13 Full quality assurance</p>	<p><input checked="" type="checkbox"/> Vertical Group</p> <p><input checked="" type="checkbox"/> Horizontal Committee</p> <p>To be endorsed by:</p> <p><input checked="" type="checkbox"/> Machinery Working Group....</p>	<p>17/09/2007</p> <p>10/06/2008</p> <p>Endorsed on:</p> <p>08/01/2009</p>
<p>Question related to: Directive 2006/42/EC Article:</p> <p>Annex: X clause 1 ESR (1):</p>	<p>EN/prEN:</p> <p>Clause:</p> <p>CEN TC concerned:</p>	<p>Other:</p> <p>Other clause:</p>
<p>Key words: final inspection, quality management, intermediate inspections</p>		
<p>Question:</p> <p>Does final inspection and testing only refer to tests after manufacturing?</p>		
<p>Solution:</p> <p>No. Although the wording of the directive suggests that the final inspection takes place after manufacturing, it seems clear that a quality management system for “design, manufacture, final inspection and testing” also contains appropriate intermediate inspections and tests during the production phase.</p> <p>These activities are under the responsibility of the manufacturer and are to be differentiated from the direct conformity assessment carried out by the Notified Bodies, however the Notified Bodies shall take account of these activities in their assessment.</p> <p>Note: Production phase includes design, manufacture, inspection, testing and storage for the machinery</p>		

(1) Essential safety requirement

Note: According to point 6.6 of the Guide of the implementation of directives based on the New Approach and the Global Approach, the notified bodies apply as general guidance this recommendation for use.

	CO-ORDINATION OF NOTIFIED BODIES Machinery Directive 2006/42/EC + Amendment RECOMMENDATION FOR USE	CNB/M/13.002 Revision 07 Language: E
Date of first stage: 13/06/2009	To be approved by:	Approved on:
Origin: VG13 Full quality assurance	<input checked="" type="checkbox"/> Vertical Group <input checked="" type="checkbox"/> Horizontal Committee To be endorsed by: <input checked="" type="checkbox"/> Machinery Working Group....	26/08/2010 14/12/2010 Endorsed on: 23/05/2011
Question related to: Directive 2006/42/EC Article: Annex: X clause 1 ESR (1):	EN/prEN: Clause: CEN TC concerned:	Other: Other clause:
Key words: quality system, compliance with standards, accreditation		
Question: Is it necessary for the manufacturer to have a quality system according to ISO 9001?		
Solution: No, compliance with the requirements of EN ISO 9001 normally provides a presumption of conformity to the relevant requirements of module H. However, since there are several additional requirements in the Annex X, compliance with ISO 9001 alone is certainly not sufficient as such to demonstrate compliance with the requirements of the directive. On the other hand, compliance with the standard is not mandatory, but the quality system must comply with the essential requirements of Annex X: no more, no less.		

(1) Essential safety requirement

Note: According to point 6.6 of the Guide of the implementation of directives based on the New Approach and the Global Approach, the notified bodies apply as general guidance this recommendation for use.

	CO-ORDINATION OF NOTIFIED BODIES Machinery Directive 2006/42/EC + Amendment RECOMMENDATION FOR USE	CNB/M/13.003 Revision 04 Language: E
Date of first stage: 21/01/2008	To be approved by:	Approved on:
Origin: VG13 Full quality assurance	<input checked="" type="checkbox"/> Vertical Group <input checked="" type="checkbox"/> Horizontal Committee	17/09/2007 10/06/2008
Question related to: Directive 2006/42/EC Article: Annex: X clause 2.1 ESR (1):	EN/prEN: Clause: CEN TC concerned:	Other: Other clause:
Key words: application, quotation, selection of Notified Body		
Question: What is meant by application in the terms of clause 2.1 of Annex X and in particular the last bullet point?		
Solution: It is not the intention of this requirement to restrict the manufacturer from obtaining several quotations, but simply prevent the practice of going from one Notified Body (NB) to another until one will issue certification. It is permissible for the Manufacturer to approach one or more Notified Bodies (NBs) and invite them to issue a quotation for providing the necessary assessment services required by Annex X of the Machinery Directive 2006/42/EC. The NBs that have been approached may require the manufacturer to supply relevant information to enable them to prepare the required quotation. This information may be submitted verbally or in written form as required by the NB. Once the manufacturer has decided to select a single NB to provide the necessary services that manufacturer shall be required to enter into an agreement (e.g. a contract) with that NB. In that agreement the manufacturer declares that they have not entered into a contract with any other NB to provide similar services for the same category or categories of machine. The selected NB will then request (if not already provided) the remaining information specified within clause 2.1 of Annex X.		

(1) Essential safety requirement

Note: According to point 6.6 of the Guide of the implementation of directives based on the New Approach and the Global Approach, the notified bodies apply as general guidance this recommendation for use.

	CO-ORDINATION OF NOTIFIED BODIES Machinery Directive 2006/42/EC + Amendment RECOMMENDATION FOR USE		CNB/M/13.004 Revision 04 Language: E
Date of first stage: 21/01/2008	To be approved by:		Approved on:
Origin: VG13 Full quality assurance	<input checked="" type="checkbox"/> Vertical Group <input checked="" type="checkbox"/> Horizontal Committee To be endorsed by: <input checked="" type="checkbox"/> Machinery Working Group....		17/09/2007 10/06/2008 Endorsed on: 08/01/2009
Question related to: Directive 2006/42/EC Article: Annex: X clause 2.1 – 2 nd indent ESR (1):	EN/prEN: Clause: CEN TC concerned:		Other: Other clause:
Key words: manufacturer, sub-contractors, conformity, supplier, subsidiaries			
Question: Do substantial subcontract activities of the manufacturer need to be identified?			
Solution: Yes. Where the manufacturers sub-contract the whole, or a significant part, of either design, manufacturing, inspection, testing or installation (where installation is part of the deliverable) they shall declare this to the Notified Body they have selected to provide the services required. Significant in this context can mean an important activity which could have a bearing upon the final conformity of the product with the applicable legislation/standards (examples are full design of the machinery, manufacturing of an important subassembly having direct impact on safety). This does not apply to safety components (e.g. light curtains) or basic sub-assemblies procured completely from a supplier. The machinery manufacturer is responsible for obtaining from his sub-contractor the information and documentation required for the application of the Annex X. If the manufacturer is not able to provide the required documentation this shall be considered to be a major nonconformity. For important subcontracting the Notified Body shall be required to visit the sub-contractor site. This shall be made by the Notified Body or on behalf of the Notified Body. It is the responsibility of the machinery manufacturer to ensure access. The basic principle is that the same logic shall be applied to a virtual manufacturer and a real manufacturer. If relevant work has been performed by different Notified Bodies at the sub-contractor site, this should be taken into account.			

(1) Essential safety requirement

Note: According to point 6.6 of the Guide of the implementation of directives based on the New Approach and the Global Approach, the notified bodies apply as general guidance this recommendation for use.

	CO-ORDINATION OF NOTIFIED BODIES Machinery Directive 2006/42/EC + Amendment RECOMMENDATION FOR USE	CNB/M/13.005 Revision 04 Language: E
Date of first stage: 28/01/2008	To be approved by:	Approved on:
Origin: VG13 Full quality assurance	<input checked="" type="checkbox"/> Vertical Group <input checked="" type="checkbox"/> Horizontal Committee To be endorsed by: <input checked="" type="checkbox"/> Machinery Working Group....	17/09/2007 10/06/2008 Endorsed on: 08/01/2009
Question related to: Directive 2006/42/EC Article: Annex: X clause 2.1 – 3 rd indent ESR (1):	EN/prEN: Clause: CEN TC concerned:	Other: Other clause:
Key words: representative model, categories of machinery, risks		
Question: Who is choosing the model and what is the category?		
Solution: The headline of Annex IV is: “Categories of machinery to which one of the procedures referred to in Article 12(3) and (4) must be applied”. Categories are therefore defined, i.e. each group of machinery listed in one of the paragraphs from 1 to 23 or paragraphs 1.1, 1.2, 1.3, 1.4, 4.1, 4.2, 12.1, 12.2. Annex X clause 2.1 – 3 rd indent refers to “one model of each category”. This model is a representative sample that displays all the major hazards identified with the machinery. For purposes of conformity assessment to Annex X, the Notify Body shall select a model that represents the most complex machine in each category form the complete list of the products manufactured.		

(1) Essential safety requirement

Note: According to point 6.6 of the Guide of the implementation of directives based on the New Approach and the Global Approach, the notified bodies apply as general guidance this recommendation for use.

	CO-ORDINATION OF NOTIFIED BODIES Machinery Directive 2006/42/EC + Amendment RECOMMENDATION FOR USE	CNB/M/13.006 Revision 02 Language: E
Date of first stage: 08/10/2007	To be approved by:	Approved on:
Origin: VG13 Full quality assurance	<input checked="" type="checkbox"/> Vertical Group <input checked="" type="checkbox"/> Horizontal Committee To be endorsed by: <input checked="" type="checkbox"/> Machinery Working Group....	17/09/2007 04/12/2007 Endorsed on: 04/06/2008
Question related to: Directive 2006/42/EC Article: Annex: X clause 2.1 – 3 rd indent ESR (1):	EN/prEN: Clause: CEN TC concerned:	Other: Other clause:
Key words: EC declaration of conformity, technical file		
Question: Is it necessary to get a copy of the EC-declaration?		
Solution: Yes. A copy of the EC declaration of conformity is a component of the technical file. That is why the applicant should submit a draft of the EC declaration of conformity to the NB.		

(1) Essential safety requirement

Note: According to point 6.6 of the Guide of the implementation of directives based on the New Approach and the Global Approach, the notified bodies apply as general guidance this recommendation for use.

	CO-ORDINATION OF NOTIFIED BODIES Machinery Directive 2006/42/EC + Amendment RECOMMENDATION FOR USE	CNB/M/13.007 Revision 03 Language: E
Date of first stage: 28/01/2008	To be approved by:	Approved on:
Origin: VG13 Full quality assurance	<input checked="" type="checkbox"/> Vertical Group <input checked="" type="checkbox"/> Horizontal Committee To be endorsed by: <input checked="" type="checkbox"/> Machinery Working Group....	17/09/2007 04/12/2007 Endorsed on: 04/06/2008
Question related to: Directive 2006/42/EC Article: Annex: X clause 2.1 - 3 rd indent ESR (1):	EN/prEN: Clause: CEN TC concerned:	Other: Other clause:
Key words: technical file, assessment on site, quality system		
Question: When does the technical file have to be made available to the NB?		
Solution: The technical file shall be made available to the NB before the assessment on site of the manufacturer is carried out. This is necessary, because the technical file will be used to validate the output of the quality system. The assessment of the quality system can only be positively finished if also the review of the technical file is positively finished. For this reason it is a recommendation for the machine manufacturer to submit the technical file as soon as possible. Note: When the NB has an experience on technical files related to specific categories of this manufacturer it may take it into account for the assessment of the technical files.		

(1) Essential safety requirement

Note: According to point 6.6 of the Guide of the implementation of directives based on the New Approach and the Global Approach, the notified bodies apply as general guidance this recommendation for use.

	CO-ORDINATION OF NOTIFIED BODIES Machinery Directive 2006/42/EC + Amendment RECOMMENDATION FOR USE	CNB/M/13.008 Revision 02 Language: E
Date of first stage: 08/10/2007	To be approved by:	Approved on:
Origin: VG13 Full quality assurance	<input checked="" type="checkbox"/> Vertical Group <input checked="" type="checkbox"/> Horizontal Committee To be endorsed by: <input checked="" type="checkbox"/> Machinery Working Group....	17/09/2007 04/12/2007 Endorsed on: 04/06/2008
Question related to: Directive 2006/42/EC Article: Annex: X clause 2.1 - 3 rd indent ESR (1):	EN/prEN: Clause: CEN TC concerned:	Other: Other clause:
Key words: complete technical file, documentation, complex machinery, audit		
Question: Does the complete technical file have to be made available?		
Solution: Yes. The complete technical file has to be made available to show that the quality system is capable of generating sufficient and complete documentation output according to the requirements of Annex VII, Part A. For complex machinery, it might be difficult to submit a very voluminous and complete technical file before the audit on site. The content of the documentation to be sent before the audit can be reduced in agreement with the NB. During the audit all the elements of the technical file must be available.		

(1) Essential safety requirement

Note: According to point 6.6 of the Guide of the implementation of directives based on the New Approach and the Global Approach, the notified bodies apply as general guidance this recommendation for use.

	CO-ORDINATION OF NOTIFIED BODIES Machinery Directive 2006/42/EC + Amendment RECOMMENDATION FOR USE	CNB/M/13.009 Revision 04 Language: E
Date of first stage: 28/01/2008	To be approved by:	Approved on:
Origin: VG13 Full quality assurance	<input checked="" type="checkbox"/> Vertical Group <input checked="" type="checkbox"/> Horizontal Committee To be endorsed by: <input checked="" type="checkbox"/> Machinery Working Group....	17/09/2007 10/06/2008 Endorsed on: 08/01/2009
Question related to: Directive 2006/42/EC Article: Annex: X clause 2.1 - 4 th indent ESR (1):	EN/prEN: Clause: CEN TC concerned:	Other: Other clause:
Key words: quality system documentation, quality management manual, certificates, audit reports, language		
Question: Shall the complete documentation according to Annex X clause 2.2 of the quality system be submitted to the Notified Body prior to the audit?		
Solution: No, the applicant must make available a controlled copy of his quality management manual or any other type of documentation acceptable to the Notified Body (NB) in due time before the audit. This need not include all detailed processes but will focus on the procedures which were specifically developed in order to comply with the requirements of the directive. During the audit the complete documentation according to Annex X clause 2.2 must be checked. The language of the provided documentation must be acceptable to the NB. If the applicant requires the NB to take into account some elements already certified by another NB and or an accredited certification body, he shall provide the related certificates. Where appropriate the NB may require to review audit reports produced during the three last years.		

(1) Essential safety requirement

Note: According to point 6.6 of the Guide of the implementation of directives based on the New Approach and the Global Approach, the notified bodies apply as general guidance this recommendation for use.

	CO-ORDINATION OF NOTIFIED BODIES Machinery Directive 2006/42/EC + Amendment RECOMMENDATION FOR USE	CNB/M/13.010 Revision 04 Language: E
Date of first stage: 08/05/2008	To be approved by:	Approved on:
Origin: VG13 Full quality assurance	<input checked="" type="checkbox"/> Vertical Group <input checked="" type="checkbox"/> Horizontal Committee To be endorsed by: <input checked="" type="checkbox"/> Machinery Working Group....	17/09/2007 10/06/2008 Endorsed on: 08/01/2009
Question related to: Directive 2006/42/EC Article: Annex: X clause 2.2 - 3 rd indent ESR (1):	EN/prEN: Clause: CEN TC concerned:	Other: Other clause:
Key words: technical design specification, sample, manufacturing facilities, inspections, audit plan		
Question: What is the role of the Notified Body of reviewing the technical design specifications?		
Solution: During the assessment of the quality system, the Notified Body will at first verify that the harmonised standards used by the manufacturer are the correct ones with regard to the different categories of machinery presented by the manufacturer. Care will be taken about the fact that there might be necessary to use different standards to cover the various types of machinery within one category. The Notified Body will also pay attention to the procedures developed by the manufacturer in order to ensure that he uses the latest version of the relevant standard. If harmonised standards are not used, or are partially used the Notified Body will evaluate the adequacy of the principles developed in order to demonstrate compliance with the requirements of the directive (see also CNB/M/13.009). The control of the effectiveness of these principles is made by the assessment of the technical file.		

(1) Essential safety requirement

Note: According to point 6.6 of the Guide of the implementation of directives based on the New Approach and the Global Approach, the notified bodies apply as general guidance this recommendation for use.

	CO-ORDINATION OF NOTIFIED BODIES Machinery Directive 2006/42/EC + Amendment RECOMMENDATION FOR USE		CNB/M/13.011 Revision 04 Language: E
Date of first stage: 28/01/2008	To be approved by:		Approved on:
Origin: VG13 Full quality assurance	<input checked="" type="checkbox"/> Vertical Group <input checked="" type="checkbox"/> Horizontal Committee		17/09/2007 10/06/2008
Question related to: Directive 2006/42/EC Article: Annex: X clause 2.2 - 2 nd indent ESR (1):	EN/prEN: Clause: CEN TC concerned:		Other: Other clause:
Key words: harmonized standards, responsibility, design review			
Question: What is the role of the Notified Body for the assessment of the technical design specifications that do not comply fully with harmonized standards?			
Solution: The Notified Body has to evaluate, whether the strategy for the selected means of the manufacturer is adequate to fulfil the requirements of the machinery directive. The manufacturer has to document the parts of a design which do not fully comply with harmonized standards and has to describe and justify (e.g. by risk assessment, use of approved practice, testing) the means that will be used to ensure that the essential health and safety requirements are fulfilled at least at an equivalent level of safety.			

(1) Essential safety requirement

Note: According to point 6.6 of the Guide of the implementation of directives based on the New Approach and the Global Approach, the notified bodies apply as general guidance this recommendation for use.

	CO-ORDINATION OF NOTIFIED BODIES Machinery Directive 2006/42/EC + Amendment RECOMMENDATION FOR USE	CNB/M/13.012 Revision 05 Language: E
Date of first stage: 28/01/2008	To be approved by:	Approved on:
Origin: VG13 Full quality assurance	<input checked="" type="checkbox"/> Vertical Group <input checked="" type="checkbox"/> Horizontal Committee To be endorsed by: <input checked="" type="checkbox"/> Machinery Working Group....	23/10/2012 (*) 10/06/2008 Endorsed on: 08/01/2009
Question related to: Directive 2006/42/EC Article: Annex: X clause 2.2 - 3 rd indent ESR (1):	EN/prEN: Clause: CEN TC concerned:	Other: Other clause:
Key words: design inspection, design verification, independence, level of confidence		
Question: Has the design inspection and design verification to be done by an independent person or department of the manufacturer?		
Solution: No, unless it is required by the quality system of the manufacturer or an applied standard. This directive, and others such as the PE-Directive and Lift Directive, and the current issue of the standard ISO 9001 do not explicitly require independence of persons or departments carrying out the design inspection and review. The manufacturer shall at least define responsibilities and competence for these persons and traceability of their actions. The manufacturer shall plan the inspection and review which shall be carried out under controlled conditions (instructions, checklists etc.). The final inspection shall include checking whether the design inspection and review has been performed correctly. Note: It is good practice to have design inspection and design verification performed by a person not directly involved in this design process. (*) Updating – to remove reference to an out of date version of ISO 9001		

(1) Essential safety requirement

Note: According to point 6.6 of the Guide of the implementation of directives based on the New Approach and the Global Approach, the notified bodies apply as general guidance this recommendation for use.

	CO-ORDINATION OF NOTIFIED BODIES Machinery Directive 2006/42/EC + Amendment RECOMMENDATION FOR USE	CNB/M/13.016 Revision 05 Language: E
Date of first stage: 2/01/2008	To be approved by:	Approved on:
Origin: VG13 Full quality assurance	<input checked="" type="checkbox"/> Vertical Group <input checked="" type="checkbox"/> Horizontal Committee	23/10/2012 (*) 10/06/2008
	To be endorsed by:	Endorsed on:
Question related to: Directive 2006/42/EC Article: Annex: X clause 2.3 ESR (1):	<input checked="" type="checkbox"/> Machinery Working Group....	08/01/2009
Question related to: Directive 2006/42/EC Article:	EN/prEN:	Other:
Annex: X clause 2.3	Clause:	Other clause:
	CEN TC concerned:	
Key words: existing certification, conformance, certified quality system		
Question: Can the NB fully rely on an existing certificate (e.g. for ISO 9001)?		
Solution: No. A quality system certified to ISO 9001 alone cannot be considered adequate to demonstrate conformance with the requirements of Annex X. An ISO 9001 certified quality system must be adapted to integrate the additional requirements of the Machinery Directive (in particular Annex X), but it is up to the Notified Body (NB) undertaking the assessment to determine the extent to further modification. Only a NB can issue certification of conformance with Annex X of the Machinery Directive and such NBs must take full and sole responsibility for such certification. (*) Updating – to remove reference to an out of date version of ISO 9001		

(1) Essential safety requirement

Note: According to point 6.6 of the Guide of the implementation of directives based on the New Approach and the Global Approach, the notified bodies apply as general guidance this recommendation for use.

	CO-ORDINATION OF NOTIFIED BODIES Machinery Directive 2006/42/EC + Amendment RECOMMENDATION FOR USE	CNB/M/13.017 Revision 02 Language: E
Date of first stage: 08/10/2007	To be approved by:	Approved on:
Origin: VG13 Full quality assurance	<input checked="" type="checkbox"/> Vertical Group <input checked="" type="checkbox"/> Horizontal Committee To be endorsed by: <input checked="" type="checkbox"/> Machinery Working Group....	17/09/2007 04/12/2007 Endorsed on: 04/06/2008
Question related to: Directive 2006/42/EC Article: Annex: X clause 2.3 ESR (1):	EN/prEN: Clause: CEN TC concerned:	Other: Other clause:
Key words: auditors, experts, competence		
Question: Must the team of the auditors consist of at least two persons?		
Solution: No. The number of auditors shall be adequate for the size of the company or the number of the people involved and the complexity and number of categories of machinery. If the auditor's competence does not cover the scope, additional experts shall accompany the auditor(s). In this context the expert(s) shall not be regarded as an auditor.		

(1) Essential safety requirement

Note: According to point 6.6 of the Guide of the implementation of directives based on the New Approach and the Global Approach, the notified bodies apply as general guidance this recommendation for use.

	CO-ORDINATION OF NOTIFIED BODIES Machinery Directive 2006/42/EC + Amendment RECOMMENDATION FOR USE		CNB/M/13.018 Revision 02 Language: E
Date of first stage: 08/10/2007	To be approved by:		Approved on:
Origin: VG13 Full quality assurance	<input checked="" type="checkbox"/> Vertical Group <input checked="" type="checkbox"/> Horizontal Committee		17/09/2007 04/12/2007
		To be endorsed by:	Endorsed on:
		<input checked="" type="checkbox"/> Machinery Working Group....	04/06/2008
Question related to: Directive 2006/42/EC	Article:	EN/prEN:	Other:
Annex: X clause 2.3	ESR (1):	Clause:	Other clause:
Key words: EHSR, technical file, review			
Question: How deep shall the review of the technical file be if its purpose is to ensure its compliance with the relevant HSR?			
Solution: Compliance with the essential health and safety requirements can only be ensured, if the technical file is reviewed in a similar manner to that required for module B, but without a detailed product inspection.			

(1) Essential safety requirement

Note: According to point 6.6 of the Guide of the implementation of directives based on the New Approach and the Global Approach, the notified bodies apply as general guidance this recommendation for use.

	CO-ORDINATION OF NOTIFIED BODIES Machinery Directive 2006/42/EC + Amendment RECOMMENDATION FOR USE	CNB/M/13.019 Revision 04 Language: E
Date of first stage: 28/01/2008	To be approved by:	Approved on:
Origin: VG13 Full quality assurance	<input checked="" type="checkbox"/> Vertical Group <input checked="" type="checkbox"/> Horizontal Committee To be endorsed by: <input checked="" type="checkbox"/> Machinery Working Group....	17/09/2007 10/06/2008 Endorsed on: 08/01/2009
Question related to: Directive 2006/42/EC Article: Annex: X clause 2.4 ESR (1):	EN/prEN: Clause: CEN TC concerned:	Other: Other clause:
Key words: product changes, changes of quality system, significant changes, contract		
Question: Is the planned change of the product covered by the planned change of the quality system?		
Solution: One of the tasks of a Notified Body (NB) in assessing and approving a full quality system is to review the technical file(s) for one model of each category of machinery referred to in Annex IV. A change of the quality system does not necessarily cause a change in the product nor - conversely - does a change of the machinery necessarily result in a change of the quality system. So the manufacturer shall only inform the NB about significant changes of the relevant technical files which may have implications on the quality system as well as direct changes of the quality system. It is recommended that contractual agreement between the NB and the manufacturer foresees the duty of the manufacturer to provide information on product changes and new products to the NB.		

(1) Essential safety requirement

Note: According to point 6.6 of the Guide of the implementation of directives based on the New Approach and the Global Approach, the notified bodies apply as general guidance this recommendation for use.

	CO-ORDINATION OF NOTIFIED BODIES Machinery Directive 2006/42/EC + Amendment RECOMMENDATION FOR USE	CNB/M/13.020 Revision 04 Language: E
Date of first stage: 28/01/2008	To be approved by:	Approved on:
Origin: VG13 Full quality assurance	<input checked="" type="checkbox"/> Vertical Group <input checked="" type="checkbox"/> Horizontal Committee To be endorsed by: <input checked="" type="checkbox"/> Machinery Working Group....	17/09/2007 10/06/2008 Endorsed on: 08/01/2009
Question related to: Directive 2006/42/EC Article: Annex: X clause 2.3 ESR (1):	EN/prEN: Clause: CEN TC concerned:	Other: Other clause:
Key words: notification, report, certificate		
Question: How should a Notified Body notify its decision?		
Solution: <p>The Notified Body (NB) shall inform the Manufacturer or Authorised Representative of their assessment decision following the visit via a written report and/or an approval certificate. If this is not provided at the end of the assessment visit itself, the written report of findings and/or approval certificate should be submitted to the Manufacturer or Authorised Representative within a reasonable timeframe, normally within one month. Where approval certification is being withheld, the written report shall contain sufficient information and reasoned judgement to enable the Manufacturer or Authorised Representative to identify and take appropriate corrective action prior to requesting a further assessment visit. Whether issued via written report or an approval certificate, the NB shall ensure that certification is supported by a scope of approval, this will define exactly what has been approved in terms of products, manufacturing locations and any particular limitations.</p>		

(1) Essential safety requirement

Note: According to point 6.6 of the Guide of the implementation of directives based on the New Approach and the Global Approach, the notified bodies apply as general guidance this recommendation for use.

	CO-ORDINATION OF NOTIFIED BODIES Machinery Directive 2006/42/EC + Amendment RECOMMENDATION FOR USE		CNB/M/13.021 Revision 04 Language: E
Date of first stage: 28/01/2008	To be approved by:		Approved on:
Origin: VG13 Full quality assurance	<input checked="" type="checkbox"/> Vertical Group <input checked="" type="checkbox"/> Horizontal Committee To be endorsed by: <input checked="" type="checkbox"/> Machinery Working Group....		17/09/2007 10/06/2008 Endorsed on: 08/01/2009
Question related to: Directive 2006/42/EC Article: Annex: X clause 3.3 ESR (1):	EN/prEN: Clause: CEN TC concerned:		Other: Other clause:
Key words: audit frequency and duration, surveillance audits			
Question: How often have surveillance audits to be done by Notified Bodies?			
Solution: The period between the audits should not be longer than 12 months. The duration and frequency of surveillance audits shall be determined by the Notified Body taking into account the complexity of the Manufacturer (e.g. number of sites, complexity of manufacturing processes, how much work is sub-contracted etc.), the products involved (e.g. the number and variety of individual products) and production volumes (e.g. higher volumes may require more frequent/longer visits). Also the former experience with this manufacturer may influence the duration and frequency of surveillance audits.			

(1) Essential safety requirement

Note: According to point 6.6 of the Guide of the implementation of directives based on the New Approach and the Global Approach, the notified bodies apply as general guidance this recommendation for use.

	CO-ORDINATION OF NOTIFIED BODIES Machinery Directive 2006/42/EC + Amendment RECOMMENDATION FOR USE	CNB/M/13.022 Revision 02 Language: E
Date of first stage: 08/10/2007	To be approved by:	Approved on:
Origin: VG13 Full quality assurance	<input checked="" type="checkbox"/> Vertical Group <input checked="" type="checkbox"/> Horizontal Committee To be endorsed by: <input checked="" type="checkbox"/> Machinery Working Group....	17/09/2007 04/12/2007 Endorsed on: 04/06/2008
Question related to: Directive 2006/42/EC Article: Annex: X clause 3.4 ESR (1):	EN/prEN: Clause: CEN TC concerned:	Other: Other clause:
Key words: unannounced visits, contracts		
Question: Are there additional conditions for unannounced visits?		
Solution: <p>Annex X of the directive indicates some of the reasons which might induce the need of unannounced visits. The frequency of these visits is a matter for the NB to determine at its discretion and, as appropriate following co-ordination with other notified bodies, but should not be unreasonable.</p> <p>A duly motivated complaint made to the NB by the Commission, a Member State, a manufacturer, another NB or any interested party is one of the factors which could trigger the need for an unexpected visit.</p> <p>It is recognised that the NB may carry out tests (or have them carried out) on the product where this is necessary to verify the quality system. Such tests should generally be confined to instances where clear evidence demonstrates that there is reasonable doubt about the effectiveness of the quality system to ensure that the machinery made under it conforms to the essential requirements of the directive.</p> <p>It is recommended that contractual agreement between the NB and the manufacturer foresees the possibility of these visits.</p>		

(1) Essential safety requirement

Note: According to point 6.6 of the Guide of the implementation of directives based on the New Approach and the Global Approach, the notified bodies apply as general guidance this recommendation for use.

	CO-ORDINATION OF NOTIFIED BODIES Machinery Directive 2006/42/EC + Amendment RECOMMENDATION FOR USE	CNB/M/13.023 Revision 04 Language: E	
Date of first stage: 08/10/2007	To be approved by:		
Origin: VG13 Full quality assurance	<input checked="" type="checkbox"/> Vertical Group <input checked="" type="checkbox"/> Horizontal Committee	Approved on: 12/05/2009 10/06/2009	
		To be endorsed by: <input checked="" type="checkbox"/> Machinery Working Group....	
Question related to: Directive 2006/42/EC	Article:	EN/prEN:	Other:
Annex: X clause 4	ESR (1):	Clause:	Other clause:
		CEN TC concerned:	
Key words: obligation to preserve			
Question: Does only the technical file referenced in 2.1 of Annex X need to be kept available for the national authorities, for a period of ten years?			
Solution: No. Conformity with Annex X does not remove the general duties of the manufacturer as defined in Annex VII A. clause 2 (all technical files should be made available to the authorities for at least 10 years).			

(1) Essential safety requirement

Note: According to point 6.6 of the Guide of the implementation of directives based on the New Approach and the Global Approach, the notified bodies apply as general guidance this recommendation for use.

	CO-ORDINATION OF NOTIFIED BODIES Machinery Directive 2006/42/EC + Amendment RECOMMENDATION FOR USE		CNB/M/13.024 Revision 04 Language: E
Date of first stage: 28/01/2008	To be approved by:		Approved on:
Origin: VG13 Full quality assurance	<input checked="" type="checkbox"/> Vertical Group <input checked="" type="checkbox"/> Horizontal Committee		17/09/2007 10/06/2008
	To be endorsed by:		Endorsed on:
	<input checked="" type="checkbox"/> Machinery Working Group....		08/01/2009
Question related to: Directive 2006/42/EC	Article:	EN/prEN: Other:	
Annex: X clause 4	ESR (1):	Clause: Other clause:	
Key words: obligation to preserve, quality assurance system documentation			
Question: Shall the Notified Body check whether a manufacturer of the machine keeps each version of the quality assurance system documentation for at least 10 years?			
Solution: Yes, the Notified Body must check whether a machine manufacturer keeps all versions of his quality assurance system which has had an effect on any Annex IV product for at least ten years after the last of those products was manufactured.			

(1) Essential safety requirement

Note: According to point 6.6 of the Guide of the implementation of directives based on the New Approach and the Global Approach, the notified bodies apply as general guidance this recommendation for use.

	CO-ORDINATION OF NOTIFIED BODIES Machinery Directive 2006/42/EC + Amendment RECOMMENDATION FOR USE		CNB/M/13.025 Revision 04 Language: E
Date of first stage: 28/01/2008	To be approved by:		Approved on:
Origin: VG13 Full quality assurance	<input checked="" type="checkbox"/> Vertical Group <input checked="" type="checkbox"/> Horizontal Committee To be endorsed by: <input checked="" type="checkbox"/> Machinery Working Group....		17/09/2007 10/06/2008 Endorsed on: 08/01/2009
Question related to: Directive 2006/42/EC Article: Annex: X clause 4 ESR (1):	EN/prEN: Clause: CEN TC concerned:		Other: Other clause:
Key words: last date of manufacture			
Question: What is meant by the last date of manufacture as used in Annex X?			
Solution: The last date of manufacture is the date upon which the last of a 'defined product' type is CE Marked with the intention of placing it on the market (be this into service or the supply chain). 'Defined product' means one that has a specific and unique identification name/number and is identified as such within a particular Technical File. The relevant records shall then be retained for a period of ten years from this last date of manufacture.			

(1) Essential safety requirement

Note: According to point 6.6 of the Guide of the implementation of directives based on the New Approach and the Global Approach, the notified bodies apply as general guidance this recommendation for use.

 <p>EUROPEAN CO-ORDINATION MACHINERY OF NOTIFIED BODIES</p>	<p>CO-ORDINATION OF NOTIFIED BODIES Machinery Directive 2006/42/EC + Amendment</p> <p>RECOMMENDATION FOR USE</p>	<p>CNB/M/13.026 Revision 02</p> <p>Language: E</p>
<p>Date of first stage: 08/10/2007</p>	<p>To be approved by:</p>	<p>Approved on:</p>
<p>Origin: VG13 Full quality assurance</p>	<p><input checked="" type="checkbox"/> Vertical Group.....</p> <p><input checked="" type="checkbox"/> Horizontal Committee</p> <p>To be endorsed by:</p> <p><input checked="" type="checkbox"/> Machinery Working Group....</p>	<p>17/09/2007</p> <p>04/12/2007</p> <p>Endorsed on:</p> <p>04/06/2008</p>
<p>Question related to: Directive 2006/42/EC</p> <p>Annex: X</p>	<p>Article:</p> <p>ESR (1):</p>	<p>EN/prEN: Other:</p> <p>Clause: Other clause:</p> <p>CEN TC concerned:</p>
<p>Key words: audit frequency and duration, assessment</p>		
<p>Question:</p> <p>Is there a minimum requirement for the time to be allocated to the assessment?</p>		
<p>Solution:</p> <p>The duration and frequency of assessment visits shall be determined by the NB taking into account the complexity of the Manufacturer (e.g. number of sites, complexity of manufacturing processes, how much work is sub-contracted etc.), the products involved (e.g. the number and variety of individual products) and production volumes (e.g. higher volumes may require more frequent/longer visits). Annex 2 of IAF Guide 62 should be used as a basis for determining a minimum baseline duration for the assessment visit (auditor time) to which additional time shall be added based upon experience gained from similar modules in other EC Directives.</p>		

(1) Essential safety requirement

Note: According to point 6.6 of the Guide of the implementation of directives based on the New Approach and the Global Approach, the notified bodies apply as general guidance this recommendation for use.

	<p style="text-align: center;">CO-ORDINATION OF NOTIFIED BODIES Machinery Directive 2006/42/EC + Amendment</p> <p style="text-align: center;">RECOMMENDATION FOR USE</p>		<p>CNB/M/13.028 Revision 03</p> <p>Language: E</p>
Date of first stage: 08/05/2008	To be approved by:		Approved on:
Origin: VG13 Full quality assurance	<input checked="" type="checkbox"/> Vertical Group <input checked="" type="checkbox"/> Horizontal Committee		17/09/2007 10/06/2008
Question related to: Directive 2006/42/EC Article: Annex: X clause 2.1 - 3 rd indent; ESR (1): clause 2.3 - 3 rd paragraph	EN/prEN: Clause: CEN TC concerned:		Other: Other clause:
Key words: technical file, sample, manufacturing facilities, inspections, audit plan			
Question: What is the role of the Notified Body in the review of the technical file?			
Solution: The role of the Notified Body (NB) is to check whether the technical file fulfils the EHRS of the MD and to verify that the quality system can produce the product in conformance with the technical file. It is not the responsibility of the NB to test the product. When studying the technical file(s) submitted by the manufacturer, the NB prepares the audit and possible inspections at the places of design, manufacture, inspection, testing and storage. This will allow him to send an audit plan to the manufacturer before his assessment. There are two steps in the review of the technical file. <ol style="list-style-type: none"> 1. The NB will make a specific analysis of one technical file duly selected for each category of machinery and provided by the manufacturer in the context of section 2.1 – 3rd indent. 2. During the audit, the NB will also review the existing technical files according to section 2.3 – 3rd paragraph. The main purpose here is to check that the existing files are established with the same approach as the sample selected for deeper analysis. <p>Note: For an annex X conformity assessment there will be no sample of the type of machinery to be examined at the site of the NB. All checks of samples to confirm compliance with the technical file have to be witnessed at the manufacturing facilities. A precondition to do these checks is the knowledge of the technical file of the representative model.</p>			

(1) Essential safety requirement

Note: According to point 6.6 of the Guide of the implementation of directives based on the New Approach and the Global Approach, the notified bodies apply as general guidance this recommendation for use.

	CO-ORDINATION OF NOTIFIED BODIES Machinery Directive 2006/42/EC + Amendment RECOMMENDATION FOR USE	CNB/M/13.031 Revision 04 Language: E	
Date of first stage: 12/05/2009	To be approved by:		
Origin: VG13 Full quality assurance	<input checked="" type="checkbox"/> Vertical Group <input checked="" type="checkbox"/> Horizontal Committee	Approved on: 12/05/2009 10/06/2009	
		To be endorsed by: <input checked="" type="checkbox"/> Machinery Working Group....	
Question related to: Directive 2006/42/EC	Article:	EN/prEN:	Other:
Annex: X	ESR (1):	Clause:	Other clause:
Key words:			
Question: What are the duties of the Notified Body when a major non-compliance with Annex X or a major non-conformity of a product with Annex I is detected? Note: A major non-conformity is the absence of, or the failure to implement and maintain, one or more quality management system requirements, or a situation which would, on the basis of available objective evidence, raise significant doubt as to the conformity of what the manufacturer is supplying.			
Solution: The Notified Body suspends the approval of the quality system and requires the manufacturer to resolve the non-conformities within the shortest possible time. If these are not corrected appropriately, the Notified Body withdraws the approval of the quality system.			
Note: There are information obligations for the Notified Bodies according to Article 14.6 of Machinery Directive.			

(1) Essential safety requirement

Note: According to point 6.6 of the Guide of the implementation of directives based on the New Approach and the Global Approach, the notified bodies apply as general guidance this recommendation for use.

	CO-ORDINATION OF NOTIFIED BODIES Machinery Directive 2006/42/EC + Amendment RECOMMENDATION FOR USE		CNB/M/13.033 Revision 04 Language: E
Date of first stage: 21/08/2008	To be approved by:		Approved on:
Origin: VG13 Full quality assurance	<input checked="" type="checkbox"/> Vertical Group <input checked="" type="checkbox"/> Horizontal Committee		23/10/2012 (*) 09/12/2008
	To be endorsed by:		Endorsed on:
	<input checked="" type="checkbox"/> Machinery Working Group....		18/06/2009
Question related to: Directive 2006/42/EC	Article:	EN/prEN:	Other:
Annex: X. 2.3.	ESR (1):	Clause:	Other clause:
CEN TC concerned:			
Key words: quality system, audit plan			
Question:			
What kind of documentation is to be delivered to the manufacturer by the Notified Body (audit plan)?			
Solution:			
The programming and planning of audits is an essential process to satisfy the needs and expectations of both Notified Body and applicant. An audit plan should be sent to the manufacturer. The audit plan should cover			
<ul style="list-style-type: none"> - Identification of the applicable standard (for instance ISO 9001) and type of audit (initial assessment, surveillance....) - The dates of the audit - The planned duration of each significant audit event - Indication of the activities and clauses to be audited. Depending on the results of previous surveillance visits, focus can be set on some parts of the quality system concerned with design and/or manufacture (results of calculations, reports on the qualification of the personnel concerned) - Identification of the audit team members - Identification of the language of the audit - Indication of the sites to be audited 			
The audit plan should be sent to the client at least five working days prior to the audit.			
(*) Updating – to remove reference to an out of date version of ISO 9001			

(1) Essential safety requirement

Note: According to point 6.6 of the Guide of the implementation of directives based on the New Approach and the Global Approach, the notified bodies apply as general guidance this recommendation for use.

	CO-ORDINATION OF NOTIFIED BODIES Machinery Directive 2006/42/EC + Amendment RECOMMENDATION FOR USE	CNB/M/13.034 Revision 04 Language: E
Date of first stage: 21/08/2008	To be approved by:	
Origin: VG13 Full quality assurance	<input checked="" type="checkbox"/> Vertical Group <input checked="" type="checkbox"/> Horizontal Committee	Approved on: 12/05/2009 10/06/2009
		To be endorsed by: <input checked="" type="checkbox"/> Machinery Working Group....
Question related to: Directive 2006/42/EC	Article:	EN/prEN:
Annex: X	ESR (1):	Other:
		Clause:
		Other clause:
		CEN TC concerned:
Key words: certificate		
Question:		
What are the minimum contents of an Annex X approval certificate?		
Solution:		
A certificate of an Annex X approval of a quality assurance system shall contain as a minimum, the;		
<ul style="list-style-type: none"> ○ manufacturers name and address; ○ scope of approval, including category and/or sub-category of machines according to Annex IV and generic product description ○ limitations of the approval (if any); ○ date of issue; ○ date of expiry; ○ issuing Notified Body; and ○ person within the Notified Body authorising the certificate ○ names and addresses of the sites which have been assessed. 		
The above reflects the minimum information necessary, but is not an exhaustive list.		
An example certificate is attached to this RfU. The names and addresses of the sites assessed shall be listed in an annex to the certificate.		

(1) Essential safety requirement

Note: According to point 6.6 of the Guide of the implementation of directives based on the New Approach and the Global Approach, the notified bodies apply as general guidance this recommendation for use.

Example Certificate

EC APPROVAL OF A QUALITY ASSURANCE SYSTEM

In accordance with the requirements of the
Machinery Directive 2006/42/EC

This is to certify that the Full Quality Assurance System of:

<Company Name>

<Company Address>

<Company Address>

has been assessed against the requirements of Annex X of Machinery Directive 2006/42/EC and conforms to the requirements for the following scope of approval:

Design and manufacture of <generic product description and any applicable limitations>

This certificate is only valid when accompanied by a current schedule with the same number detailing the categories of machinery corresponding to this approval.

Approval is subject to the continued surveillance of the Full Quality Assurance System in accordance with the requirements of the above Directive. Unauthorised changes to the Full Quality Assurance System will render this approval invalid.

Authorisation is hereby given to use the Notified Body Identification Number in accordance with the requirements of the specified Directive in relation to the categories of machinery identified in this certificate and accompanying schedule.

Certificate No: <Certificate Number>

Original Approval: <Original Issue Date>

Current Certificate: <Subsequent Issue Date>

Certificate Expiry: <Expiry Date>



Notified Body Number <NB Number>

Issued by: <NB Signatory>

	CO-ORDINATION OF NOTIFIED BODIES Machinery Directive 2006/42/EC + Amendment RECOMMENDATION FOR USE	CNB/M/13.037 Revision 03 Language: E
Date of first stage: 12/05/2009	To be approved by:	Approved on:
Origin: VG13 Full quality assurance	<input checked="" type="checkbox"/> Vertical Group <input checked="" type="checkbox"/> Horizontal Committee To be endorsed by: <input checked="" type="checkbox"/> Machinery Working Group....	12/05/2009 10/06/2009 Endorsed on: 25/12/2009
Question related to: Directive 2006/42/EC Article: Annex: X clause 3.2 ESR (1):	EN/prEN: Clause: CEN TC concerned:	Other: Other clause:
Key words: surveillance, quality system, technical file		
Question: According to Annex X, 2.1 the manufacturer has to lodge an application for assessment of this quality system containing the technical file for one model of each category of machinery he intends to manufacture. Is it acceptable if in the process of approval of the technical file there is no possibility to see the product during the assessment of the quality system by the Notified Body?		
Solution: No. At the very first audit the NB has to see at least one model of each category of machinery to assess the full quality assurance system. Where this model is different from the technical file that was audited a model of equivalent complexity has to be assessed at least once during each period of three years.		

(1) Essential safety requirement

Note: According to point 6.6 of the Guide of the implementation of directives based on the New Approach and the Global Approach, the notified bodies apply as general guidance this recommendation for use.

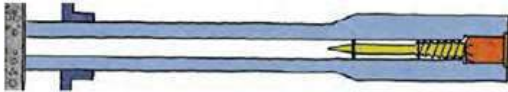
	CO-ORDINATION OF NOTIFIED BODIES Machinery Directive 2006/42/EC + Amendment RECOMMENDATION FOR USE	CNB/M/14.001 Revision 03 Language: E																										
Date of first stage: 17.10.2013	To be approved by:	Approved on:																										
Origin: VG 14 Portable cartridge-operated fixing and other impact machinery	<input checked="" type="checkbox"/> Vertical Group <input checked="" type="checkbox"/> Horizontal Committee To be endorsed by: <input checked="" type="checkbox"/> Machinery Working Group....	11/12/2013 18/06/2014 Endorsed on: 08/01/2015																										
Question related to: Directive 2006/42/EC Article: 2.2.2 Annex: I and IV ESR (1):	EN/prEN: EN 15895 Clause: 6.5 GEN TC concerned: TC 213 WG 2	Other: EN16264 Other clause: ISO12100																										
Key words: Bolt setting devices, Cattle stunners, other hand held cartridge operated fixing and impact machinery																												
Question: What kind of devices have to be treated under the Machine Directive Annex IV, No.18.																												
Solution: Cartridge operated portable fixing and other impact machinery must be designed and constructed in such a way that energy is transmitted to the impacted element by the intermediary component that does not leave the device:																												
Classification of all known technical cartridge operated devices:																												
Cartridge Actuated Devices :	<table border="1"> <thead> <tr> <th data-bbox="798 1176 1117 1288">a) covered by Annex IV of MD</th> <th data-bbox="1117 1176 1509 1288">b) considered as fire arms not in scope of MD</th> </tr> </thead> <tbody> <tr> <td data-bbox="798 1288 1117 1332" style="text-align: center;">X</td> <td data-bbox="1117 1288 1509 1332"></td> </tr> <tr> <td data-bbox="798 1332 1117 1377"></td> <td data-bbox="1117 1332 1509 1377" style="text-align: center;">X</td> </tr> <tr> <td data-bbox="798 1377 1117 1422" style="text-align: center;">X</td> <td data-bbox="1117 1377 1509 1422"></td> </tr> <tr> <td data-bbox="798 1422 1117 1467" style="text-align: center;">X*</td> <td data-bbox="1117 1422 1509 1467"></td> </tr> <tr> <td data-bbox="798 1467 1117 1512"></td> <td data-bbox="1117 1467 1509 1512" style="text-align: center;">X</td> </tr> <tr> <td data-bbox="798 1512 1117 1556"></td> <td data-bbox="1117 1512 1509 1556" style="text-align: center;">X</td> </tr> <tr> <td data-bbox="798 1556 1117 1601"></td> <td data-bbox="1117 1556 1509 1601" style="text-align: center;">X</td> </tr> <tr> <td data-bbox="798 1601 1117 1646"></td> <td data-bbox="1117 1601 1509 1646" style="text-align: center;">X</td> </tr> <tr> <td data-bbox="798 1646 1117 1691"></td> <td data-bbox="1117 1646 1509 1691" style="text-align: center;">X</td> </tr> <tr> <td data-bbox="798 1691 1117 1736" style="text-align: center;">X</td> <td data-bbox="1117 1691 1509 1736"></td> </tr> <tr> <td data-bbox="798 1736 1117 1780"></td> <td data-bbox="1117 1736 1509 1780" style="text-align: center;">X</td> </tr> <tr> <td data-bbox="798 1780 1117 1809"></td> <td data-bbox="1117 1780 1509 1809" style="text-align: center;">X</td> </tr> </tbody> </table>		a) covered by Annex IV of MD	b) considered as fire arms not in scope of MD	X			X	X		X*			X		X		X		X		X	X			X		X
a) covered by Annex IV of MD	b) considered as fire arms not in scope of MD																											
X																												
	X																											
X																												
X*																												
	X																											
	X																											
	X																											
	X																											
	X																											
X																												
	X																											
	X																											
																												
a) Indirect actuating principle according to M.D.	b) direct actuating principle																											
*See Guide to Application of the Machinery Directive 2006/42/EC, Print Version: June 2010, 2. Edition, para. 280																												

(1) Essential safety requirement

Note: According to point 6.6 of the Guide of the implementation of directives based on the New Approach and the Global Approach, the notified bodies apply as general guidance this recommendation for use.