

- 1 - Scope
- 2 - Normative references
- 3 - Terms and definitions
- 4 - Safety requirements and/or protective measures
- 5 - Verification
 - 5.1 - Methods of verification
 - 5.2 - Test procedures and conditions
 - 5.2.1 - General
 - 5.2.2 - Conceptual verification by calculation
 - 5.2.3 - Conceptual verification by experiment
 - 5.2.4 - Examination after test
 - 5.2.5 - Test report
 - 5.3 - Verification based on noise emission values
- 6 - Information for use
 - 6.1 - Format of instruction
 - 6.1.1 - General
 - 6.1.2 - Technical data and information
 - 6.2 - Instructions for use
 - 6.2.1 - General
 - 6.2.2 - Crane operator instructions
 - 6.2.2.1 - Checks before starting a crane operation
 - 6.2.2.2 - Specific safety requirements during operation
 - 6.2.2.3 - Leaving the mobile crane out-of-service
 - 6.3 - Instructions for assembly, erection, disassembly and transport
 - 6.4 - Instructions for maintenance and inspection
 - 6.5 - Instructions for training
 - 6.6 - Instructions for spare parts
 - 6.7 - Instructions for disposal
- 7 - Marking
 - 7.1 - Machine marking
 - 7.2 - Information and warning
 - 7.3 - Graphic symbols
 - 7.4 - Marking of crane parts
 - 7.5 - Marking of outriggers
 - 7.6 - Marking data recorder

Codice: 7.4 Titolo: Marking of crane parts

Tahoma 8 B I U

Parts of the crane which are disassembled and transported separately (e.g. lattice jib intersection, part of the counterweight) shall be identified by markings if there is a risk of unintended interchange.

NOTE

For connecting elements (e.g. pins, bolts, screws) separate transport positions on the main parts (e.g. lattice jib intersection) should preferably be provided. For main parts which need to be handled by using load lifting attachments, the weight, the position of the lifting lugs and for non symmetrical parts the centre of gravity shall be marked on the part itself. If these parts need to be handled in combination with other parts during assembly/disassembly such information shall be given in respective configuration/transport drawings.

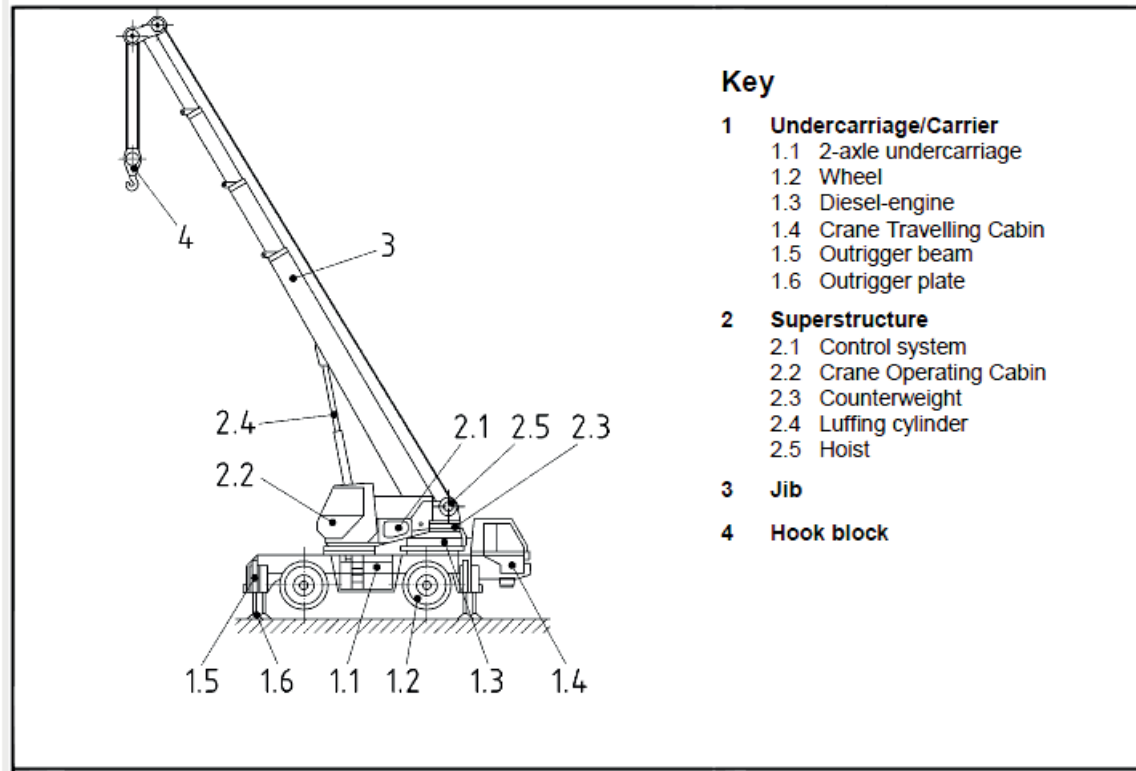

EN 13000:2010

Apparecchi di sollevamento - Gru mobili

English Version

Cranes - Mobile cranes

Appareils de levage à charge suspendue - Grues mobiles

Krane - Fahrzeugkrane

This European Standard was approved by CEN on 19 December 2009.

CEN members are bound to comply with the CEN/CENELEC Internal Regulations which stipulate the conditions for giving this European Standard the status of a national standard without any alteration. Up-to-date lists and bibliographical references concerning such national standards may be obtained on application to the CEN Management Centre or to any CEN member.

This European Standard exists in three official versions (English, French, German). A version in any other language made by translation under the responsibility of a CEN member into its own language and notified to the CEN Management Centre has the same status as the official versions.

CEN members are the national standards bodies of Austria, Belgium, Bulgaria, Cyprus, Czech Republic, Denmark, Estonia, Finland, France, Germany, Greece, Hungary, Iceland, Ireland, Italy, Latvia, Lithuania, Luxembourg, Malta, Netherlands, Norway, Poland, Portugal, Romania, Slovakia, Slovenia, Spain, Sweden, Switzerland and United Kingdom.



EUROPEAN COMMITTEE FOR STANDARDIZATION
COMITÉ EUROPÉEN DE NORMALISATION
EUROPÄISCHES KOMITEE FÜR NORMUNG

Management Centre: Avenue Marnix 17, B-1000 Brussels