Earth-moving machinery — Laboratory tests and performance requirements for protective structures of excavators —
Part 2:
Roll-over protective structures (ROPS) for excavators of over 6 t

Engins de terrassement — Essais de laboratoire et exigences de performance des structures de protection des pelles —

Partie 2: Structures de protection au retournement (ROPS) pour pelles de terrassement de plus de 6 t



PDF disclaimer

This PDF file may contain embedded typefaces. In accordance with Adobe's licensing policy, this file may be printed or viewed but shall not be edited unless the typefaces which are embedded are licensed to and installed on the computer performing the editing. In downloading this file, parties accept therein the responsibility of not infringing Adobe's licensing policy. The ISO Central Secretariat accepts no liability in this area.

Adobe is a trademark of Adobe Systems Incorporated.

Details of the software products used to create this PDF file can be found in the General Info relative to the file; the PDF-creation parameters were optimized for printing. Every care has been taken to ensure that the file is suitable for use by ISO member bodies. In the unlikely event that a problem relating to it is found, please inform the Central Secretariat at the address given below.

**COPYRIGHT PROTECTED DOCUMENT**

© ISO 2008

All rights reserved. Unless otherwise specified, no part of this publication may be reproduced or utilized in any form or by any means, electronic or mechanical, including photocopying and microfilm, without permission in writing from either ISO at the address below or ISO's member body in the country of the requester.

ISO copyright office
Case postale 56 • CH-1211 Geneva 20
Tel. + 41 22 749 01 11
Fax + 41 22 749 09 47
E-mail copyright@iso.org
Web www.iso.org

Published in Switzerland

Contents

Page

Foreword	iv
Introduction	v
1 Scope	1
2 Normative references	1
3 Terms and definitions	2
4 Symbols and abbreviated terms	6
5 Test method and facilities	12
6 Test loading procedure	14
7 Material temperature criteria	18
8 Acceptance criteria	19
9 Labelling of the ROPS	23
10 Reported results	24
11 Operator's manual	24
Annex A (normative) Test report for ROPS conforming to ISO 12117-2	25
Annex B (informative) Design changes, physical testing and alterations	28
Annex C (informative) Rationale — ROPS performance requirements	29
Bibliography	32

Foreword

ISO (the International Organization for Standardization) is a worldwide federation of national standards bodies (ISO member bodies). The work of preparing International Standards is normally carried out through ISO technical committees. Each member body interested in a subject for which a technical committee has been established has the right to be represented on that committee. International organizations, governmental and non-governmental, in liaison with ISO, also take part in the work. ISO collaborates closely with the International Electrotechnical Commission (IEC) on all matters of electrotechnical standardization.

International Standards are drafted in accordance with the rules given in the ISO/IEC Directives, Part 2.

The main task of technical committees is to prepare International Standards. Draft International Standards adopted by the technical committees are circulated to the member bodies for voting. Publication as an International Standard requires approval by at least 75 % of the member bodies casting a vote.

Attention is drawn to the possibility that some of the elements of this document may be the subject of patent rights. ISO shall not be held responsible for identifying any or all such patent rights.

ISO 12117-2 was prepared by Technical Committee ISO/TC 127, *Earth-moving machinery*, Subcommittee SC 2, *Safety, ergonomics and general requirements*.

ISO 12117 consists of the following parts, under the general title *Earth-moving machinery — Laboratory tests and performance requirements for protective structures of excavators*:

- *Part 1: Tip over protective structures (TOPS) for compact excavators*
- *Part 2: Roll-over protective structures (ROPS) for excavators of over 6 t*

Introduction

It was long thought that hydraulic excavators did not overturn as easily as other earth-moving machines because their large attachments support the machine bodies once they start inclining. However, in some regions of the world, accident data have shown a need for roll-over protection of hydraulic excavators. Standardization was thus needed.

This part of ISO 12117 provides a test method for roll-over protective structures (ROPS) for hydraulic excavators of over 6 t used in earth-moving. Unlike the machines covered by ISO 3471, hydraulic excavators feature large attachments which affect the required performance capability of the ROPS. Therefore, the test method and criteria required for hydraulic excavators are different from those needed for the other earth-moving machines.

It is also applicable to hydraulic excavators used in forestry applications. The criteria of ROPS for hydraulic excavators, used in forestry, with cab riser, have been included for information.

Earth-moving machinery — Laboratory tests and performance requirements for protective structures of excavators —

Part 2: Roll-over protective structures (ROPS) for excavators of over 6 t

1 Scope

This part of ISO 12117 establishes a consistent and reproducible means of evaluating the load-carrying characteristics of roll-over protective structures (ROPS) for excavators under static loading, and prescribes performance requirements of a representative specimen under such loading.

It applies to ROPS of hydraulic excavators as defined in ISO 6165 with a mass of over 6 t and less than 50 t. ROPS will ensure minimum crush protection space for a seat-belted operator when the machine rolls 360° about longitudinal axis of its revolving frames without losing contact with a hard clay slope of less than 30°. ROPS is to be applied where the risk of roll-over exists.

It also applies to ROPS for excavator-based or derivated excavators used in object or material handling, demolition or with attachments such as magnets, clamshell, grab or multi-claw grab.

It does not apply to excavators with elevating cab risers.

NOTE This part of ISO 12117 is intended to be applied to excavators having a gross operating mass up to 50 000 kg due to the limitation of the experimental and statistical data set used to derive acceptance criteria. This does not preclude the possibility of applying the procedure described in this part of ISO 12117 to excavators having larger or smaller masses, with the exclusion of excavators specially designed for mining application, where the requirements may lead to impractical design.

2 Normative references

The following referenced documents are indispensable for the application of this document. For dated references, only the edition cited applies. For undated references, the latest edition of the referenced document (including any amendments) applies.

ISO 3164, *Earth-moving machinery — Laboratory evaluations of protective structures — Specifications for deflection-limiting volume*

ISO 5353, *Earth-moving machinery, and tractors and machinery for agriculture and forestry — Seat index point*

ISO 6165, *Earth-moving machinery — Basic types — Identification and terms and definitions*

ISO 9248, *Earth-moving machinery — Units for dimensions, performance and capacities, and their measurement accuracies*

ISO 12117-2:2008(E)**3 Terms and definitions**

For the purposes of this document, the following terms and definitions apply.

3.1**attachment**

assembly of components that can be mounted onto the base machine or equipment for specific use

[ISO 6016:—, definition 3.1.4]

3.2**bedplate**

substantially rigid part of the test fixtures to which the machine frame is attached for the purpose of the test

3.3**boundary plane****BP**

plane defined as the vertical projected planes of the back, side and knee area of the DLV

NOTE The boundary plane is used to determine the load application zone.

3.4**boundary simulated ground plane****BSGP**

plane, defined by structurally stiff points on the machine, that can provide additional protection for the operator during impact with the ground during a machine roll-over

NOTE For verification of stiff points, see 6.1.5.

3.5**cab riser**

any spacer that increases the height of the seat index point (SIP), as defined in ISO 5353, greater than 250 mm relative to normal configuration

3.6**deflection-limiting volume****DLV**

orthogonal approximation of a large, seated male operator wearing normal clothing and a protective helmet

NOTE Adapted from ISO 3164:1995, definition 3.1.

3.7**deflection of ROPS****deflection**

movement of the ROPS, mounting system and frame section, as measured at the load application point, excluding the effect of any movement of the test fixture(s)

3.8**equipment**

set of components mounted onto the base machine that allows an attachment to perform the primary design function of the machine

3.9**ground reference plane****GRP**

pre-established plane representing a hard, flat surface on which the machine might come to rest

3.10

**lateral boundary simulated ground plane
LBSGP**

plane defined by the machine LH (left-hand) side three stiff portions (e.g. boom side highest portion, machine cab supporting frame LH front-most portion, counterweight LH side upper portion), when the machine comes to rest on its side, with the machine equipment and attachment at minimum boom height as specified by the manufacturer, and at maximum reach at GRP position

See Figure 1.

NOTE LBSGP contains three stiff points, for example, the LH counterweight edge, the LH highest point of boom when equipment and attachment are in the position of maximum reach above ground, and the LH front part of the deckframe.

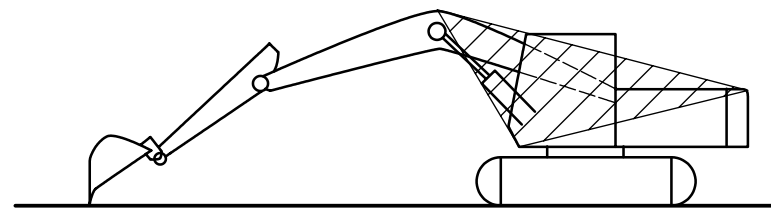

a) LBSGP

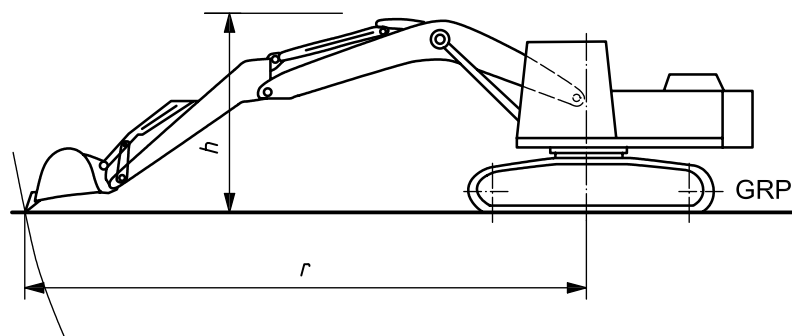

b) Minimum boom height

Key

- h* minimum boom height
- r* maximum reach on the ground
- GRP ground reference plane

Figure 1 — Lateral boundary simulated ground plane (LBSGP)

3.11

**lateral simulated ground plane
LSGP**

plane defined where the machine comes to rest on its side

See Figure 2.

NOTE 1 This plane is pre-established by rotating a vertical plane parallel to the machine's longitudinal centreline, creating a new plane passing through the outermost point of the upper ROPS structural member, to which the lateral load is applied, and a second lower point on the machine.

ISO 12117-2:2008(E)

NOTE 2 Each of the two hard points, noted as a and e in Figure 2, are capable of supporting one half of the machine mass.

NOTE 3 The LSGP is established on an unloaded ROPS and moves with the ROPS member to which the load is applied while maintaining its pre-established angle with respect to the vertical.

NOTE 4 The LSGP applies to conditions where the machine comes to rest on two hard points. If a third hard point is to be considered, then LBSGP can be applicable.

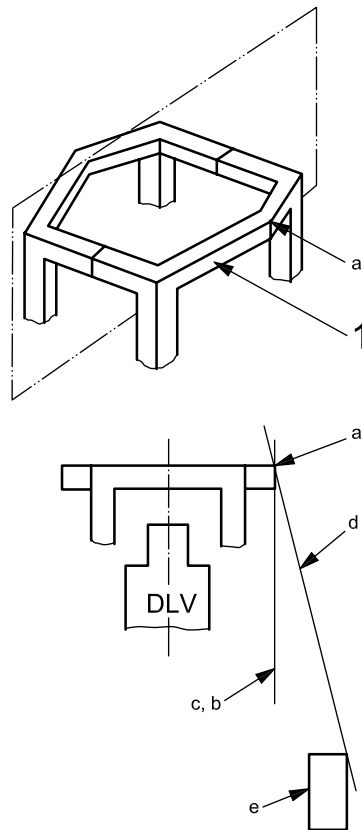

Key

- 1 upper ROPS frame member to which the lateral load is applied
- a Outermost point from the end view of frame member.
- b Vertical line through the outermost point from the end view of frame member.
- c Vertical plane parallel to the machine longitudinal centreline through line b.
- d LSGP.
- e Certain high rigidity portion of a machine used to establish LSGP.

Figure 2 — Lateral simulated ground plane (LSGP)

**3.12
load application point
LAP**

point on the ROPS structure at which the test load force, F , is applied

**3.13
load distribution device
LDD**

device used to prevent localized penetration of the ROPS members at the load application point

3.14**one- or two-post ROPS**

one- or two-post ROPS formed or fabricated having cantilevered load-carrying structural member(s)

3.15**operating mass****OM**

mass of the base machine, with equipment and empty attachment in the most usual configuration as specified by the manufacturer, and with the operator (75 kg), full fuel tank and all fluid systems (i.e. hydraulic oil, transmission oil, engine oil, engine coolant) at the levels specified by the manufacturer and, when applicable, with sprinkler water tank(s) half-full

NOTE 1 The mass of an operator is not included for non-riding machines.

NOTE 2 Ballast mass at delivery can be included if specified by the manufacturer.

[ISO 6016:—, definition 3.2.1]

NOTE 3 Soil, mud, rocks, branches, debris, etc. that commonly adhere to, or lie on, the machine in use are not considered part of the mass of any machine. Material dug, carried or handled in any manner is not considered part of the machine mass in determining test requirements.

3.16**operator protective guards****OPG**

system consisting of a top guard and a front guard to provide object protection to the operator station of the excavator

NOTE Adapted from ISO 10262:1998, definition 3.1.

3.17**representative specimen**

ROPS, mounting hardware and machine frame (complete or partial) used for test purposes that is within the range of material and manufacturing variances designated to the manufacturer's production specifications

NOTE The intent is that all the ROPS manufactured to these specifications are capable of meeting or exceeding the stated levels of performance.

3.18**rollbar ROPS**

one- or two-post ROPS without FOPS or any cantilevered load-carrying structural members

[ISO 3471]

3.19**roll-over protective structure****ROPS**

system of mainly metallic structural members whose primary purpose is to provide a seated operator, held by a seat restraint system, with reasonable protection in the event of a machine overturning (roll-over)

NOTE Structural members include any subframe, bracket, mounting, socket, bolt, pin, suspension, flexible shock absorber used to secure the system to the revolving frame, but exclude mounting provisions that are integral to the revolving frame.

3.20**ROPS structural member**

member designed to withstand applied force or absorb energy

EXAMPLE Sub-frame, bracket, mounting, socket, bolt, pin, suspension, flexible shock absorber.